



Faculty of  
**Science**  
Handbook



University of Technology, Sydney

---

**1998**

***UTS Faculty of  
Science  
Handbook  
1998***

The University attempts to ensure that the information contained in this handbook is correct as at 28 November 1997. The University reserves the right to vary any matter described in the handbook at any time without notice.



University of Technology, Sydney

**Equal opportunity**

It is the policy of the University of Technology, Sydney to provide equal opportunity for all persons regardless of sex, race, marital status, family responsibilities, disability, sexual preference, age, political conviction or religious belief.

**Free speech**

The University supports the right to freedom of speech and the rights of its members to contribute to the diversity of views presented in our society.

**Non-discriminatory language**

UTS has adopted the use of non-discriminatory language as a key strategy in providing equal opportunity for all staff and students. Guidelines for the use of non-discriminatory language have been developed and all members of the University community are encouraged to use them.

**Editorial and production:**

Publications Branch,  
Registrar's Division

**Cover**

*UTS – The Global Classroom*  
*UTS congratulates our first group of International Studies students who will spend 1998 studying overseas in the country of their choice.*

External Relations Unit

# Table of contents

---

<b>General University information</b>	<b>5</b>
Preface	5
Addresses and telephone numbers	6
Campus maps	7
Applying for UTS courses	11
UTS Information Centres	11
Principal dates for 1998	12
<b>Faculty information</b>	<b>14</b>
Message from the Dean	14
Faculty Mission Statement	14
Faculty of Science	15
Units within the Faculty	17
Centres and Institutes	18
Information for students	21
Prizes and scholarships	27
List of courses and codes	33
International Studies electives	35
<b>Undergraduate courses</b>	<b>36</b>
<b><i>Pass Degree courses</i></b>	<b>36</b>
<b><i>Honours Degree courses</i></b>	<b>38</b>
Bachelor of Science in Applied Chemistry	39
Bachelor of Science (Honours) in Applied Chemistry	42
Bachelor of Science (Honours) in Applied Chemistry – Forensic Science	43
Bachelor of Applied Science in Geology	44
Bachelor of Science in Earth and Environmental Science	46
Bachelor of Science (Honours) in Geoscience	48
Bachelor of Science (Honours) in Environmental Science	48
Bachelor of Science in Materials Science	49
Bachelor of Science (Honours) in Materials Science	51
Bachelor of Science in Applied Physics	52
Bachelor of Science (Honours) in Applied Physics	55
Bachelor of Science in Applied Physics/Bachelor of Engineering in Electrical Engineering/Diploma in Engineering Practice	56
Bachelor of Health Science in Acupuncture	57
Bachelor of Health Science in Acupuncture (Honours)	58
Bachelor of Health Science in Acupuncture/ Bachelor of Arts in International Studies	58
Bachelor of Health Science in Chinese Herbal Medicine	60
Bachelor of Health Science in Chinese Herbal Medicine (Honours)	61
Bachelor of Medical Science	61
Bachelor of Science (Honours)	62
Bachelor of Science in Biomedical Science	63
Bachelor of Science in Biotechnology	66
Bachelor of Science in Environmental Biology	70
Bachelor of Science in Environmental and Urban Horticulture	72
Bachelor of Science in Science Education	75



Bachelor of Science/Bachelor of Laws	76
Bachelor of Medical Science/Bachelor of Laws	79
Bachelor of Science/Bachelor of Arts in International Studies	80
<b>Second majors</b>	<b>82</b>
<b>Postgraduate courses</b>	<b>85</b>
<b>Graduate Certificate courses</b>	<b>85</b>
Graduate Certificate in Clinical Biochemistry	86
Graduate Certificate in Biochemical Analysis	86
Graduate Certificate in Medical Biochemistry	86
Graduate Certificate in Coastal Resource Management	86
Graduate Certificate in Principles of Ecotoxicology	87
Graduate Certificate in Laboratory Methods in Ecotoxicology	87
Graduate Certificate in Field Methods in Ecotoxicology	87
Graduate Certificate in Management in Ecotoxicology	87
Graduate Certificate in Environmental Engineering and Management	88
Graduate Certificate in Medical Microbiology	89
Graduate Certificate in Molecular Microbiology	89
Graduate Certificate in Diagnostic Bacteriology	89
Graduate Certificate in Parasitology and Mycology	89
Graduate Certificate in Occupational Health and Safety	89
Graduate Certificate in Occupational Health and Safety Management	89
<b>Graduate Diploma courses</b>	<b>90</b>
Graduate Diploma in Hydrogeology and Groundwater Management	90
Graduate Diploma in Occupational Health and Safety	91
<b>Master's Degrees (by coursework)</b>	<b>92</b>
Master of Coastal Resource Management	93
Master of Health Science in Traditional Chinese Medicine	94
Master of Occupational Health and Safety	95
Master of Science in Clinical Biochemistry	95
Master of Science (Honours) in Clinical Biochemistry	96
Master of Science in Ecotoxicology	97
Master of Science (Honours) in Ecotoxicology	98
Master of Science in Hydrogeology and Groundwater Management	98
Master of Science in Medical Microbiology	99
Master of Science (Honours) in Medical Microbiology	100
<b>Postgraduate Degrees by research/thesis</b>	<b>101</b>
<b>Subject descriptions</b>	<b>102</b>
Subjects offered for Faculty of Nursing students	165
Subjects offered by other faculties	167
International Studies subjects	171
<b>Alphabetical list of subjects</b>	<b>173</b>
<b>Boards and committees</b>	<b>178</b>
Faculty Board in Science	178
Course Advisory Committees	179
<b>Staff List</b>	<b>184</b>
<b>Index</b>	<b>192</b>

# **General University information**

---

## **PREFACE**

Welcome to the University of Technology, Sydney (UTS), the fourth largest university in New South Wales. UTS has a reputation for delivering quality higher education that meets the needs of the professions, the technologies and the community. It is a multicampus university operating at three major locations in the Sydney metropolitan area – Broadway, Kuring-gai and St Leonards – and offering over 80 undergraduate and 200 postgraduate courses to nearly 22,000 students.

The main work of course development and delivery at UTS is carried out by the Faculties of Business; Design, Architecture and Building; Education; Engineering; Humanities and Social Sciences; Law; Mathematical and Computing Sciences; Nursing; and Science; and the Institute for International Studies. Each of these is responsible for a range of programs across a number of key disciplines.

Every year UTS produces 10 faculty/institute handbooks containing information about all the courses and subjects offered at UTS, and including details of course content, attendance patterns, credit point requirements and combined degrees, plus important faculty and student information.

These handbooks are part of a suite of publications which includes the *UTS Calendar* and the postgraduate and undergraduate student handbooks. The *UTS Calendar* contains the University Act, By-law and Rules, a list of courses offered at the University, and other useful University information. Copies are held in the University's libraries and faculty offices, and may be purchased at the Co-op Bookshop. The student handbooks contain general information about application procedures, academic progression, assistance schemes, and services and facilities offered to students. You will be given a free copy of one of these when you enrol.

If you need more information about the University or its courses, you can contact the UTS Information Service or your faculty office. The University provides a whole range of services for students, and there are plenty of qualified people here to give you help and advice.

We hope you enjoy your time as a student at UTS, and wish you well in your studies.

## ADDRESSES AND TELEPHONE NUMBERS

### University of Technology, Sydney

#### Postal address

PO Box 123  
Broadway  
NSW 2007 Australia

#### Telephone

(02) 9514 2000  
International: +61 2 9514 2000  
Fax: (02) 9514 1551

#### World Wide Web

<http://www.uts.edu.au>

#### City campus

##### Broadway

- Building 1 (Tower Building)  
1 Broadway, Ultimo
- Building 2  
1 Broadway, Ultimo
- Building 3 (Bon Marche Building)  
Cnr Harris St and Broadway, Ultimo
- Building 4  
Cnr Thomas and Harris Streets, Ultimo
- Building 6  
702–730 Harris St, Ultimo
- Broadway Terraces  
9, 11 and 13 Broadway, Ultimo
- Magic Pudding Childcare Centre  
Thomas St, Ultimo

##### Haymarket

- Building 5  
Cnr Quay St and Ultimo Rd, Ultimo

##### Blackfriars

- Cnr Blackfriars and Buckland Steets,  
Chippendale
- Blackfriars Childrens Centre  
Buckland St, Chippendale

##### Smail Street

- 3 Smail St, Ultimo

##### Wembley House

- 839–847 George St, Sydney

#### Harris Street

- 645 Harris St, Ultimo

#### Student housing

- Bulga Ngurra  
23–27 Mountain St, Ultimo
- Geegal  
82–84 Ivy St, Ultimo

#### Australian Technology Park Sydney Ltd

##### Institute for Sustainable Futures

- Suite 213  
National Innovation Centre  
Cnr Garden, Cornwallis and Boundary  
Streets  
Eveleigh NSW 1430  
Telephone: (02) 9209 4350  
Fax: (02) 9209 4351

#### Kuring-gai campus

- Eton Rd, Lindfield  
(PO Box 222, Lindfield NSW 2070)

#### St Leonards campus

- Dunbar Building  
Cnr Pacific Highway and  
Westbourne St, Gore Hill
- Clinical Studies Building, Centenary  
Lecture Theatre and West Wing  
Reserve Rd, Royal North Shore Hospital
- Gore Hill Research Laboratories  
Royal North Shore Hospital

#### Yarrowood conference and research centre

- 689 Springwood Rd  
Yarramundi NSW 2753

#### Stroud Field Station

- 2605 The Bucketts Way  
Booral NSW 2425

# CAMPUS MAPS

## City campus

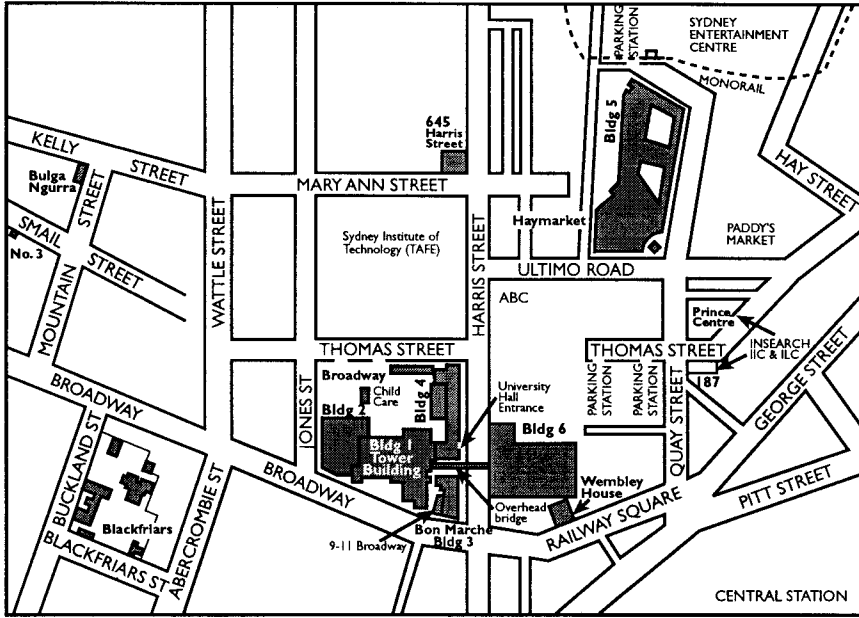

## Broadway

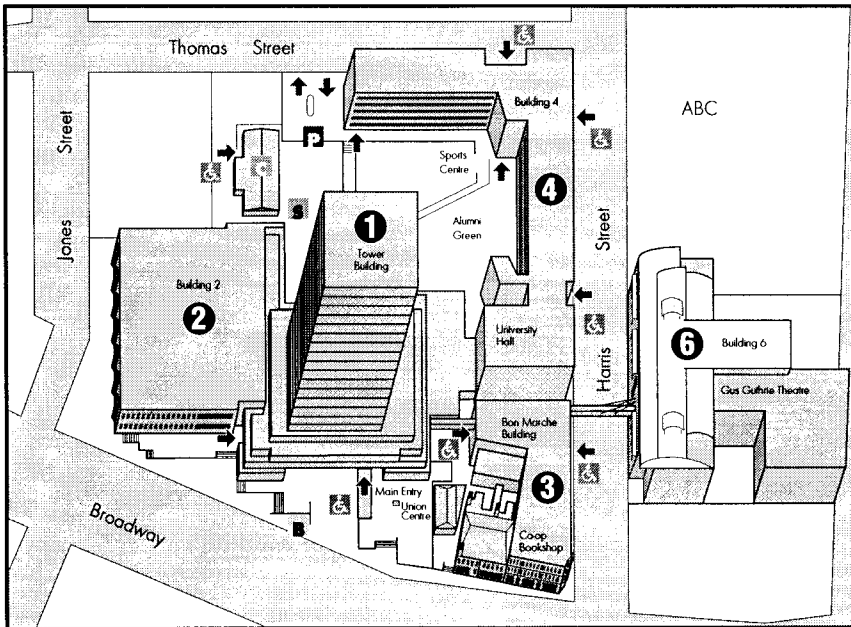

Haymarket

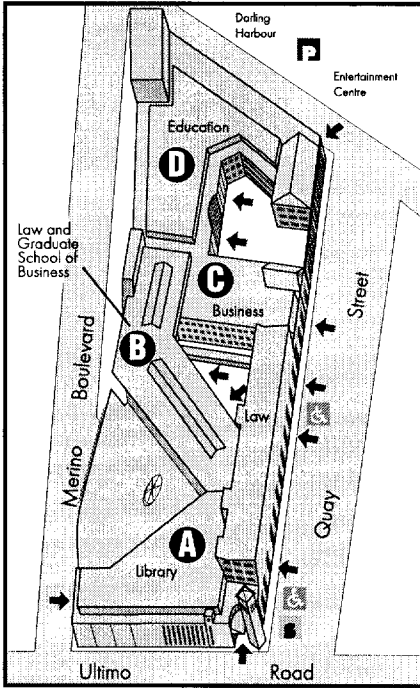

**KEY**

- ➔ Entry/Exit
- ♿ Disabled access
- B** Main bus stop
- S** UTS shuttle bus
- P** Parking
- 1** Building numbers
- ♿ Child care

Blackfriars

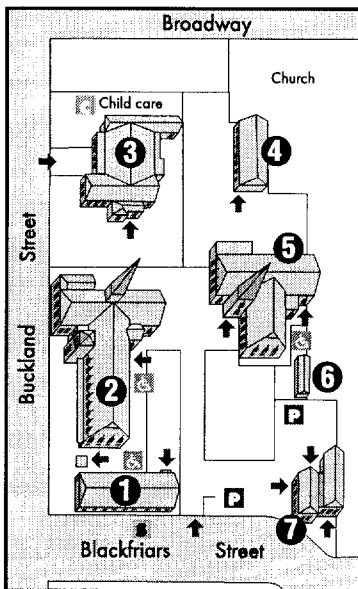

### Kuring-gai campus

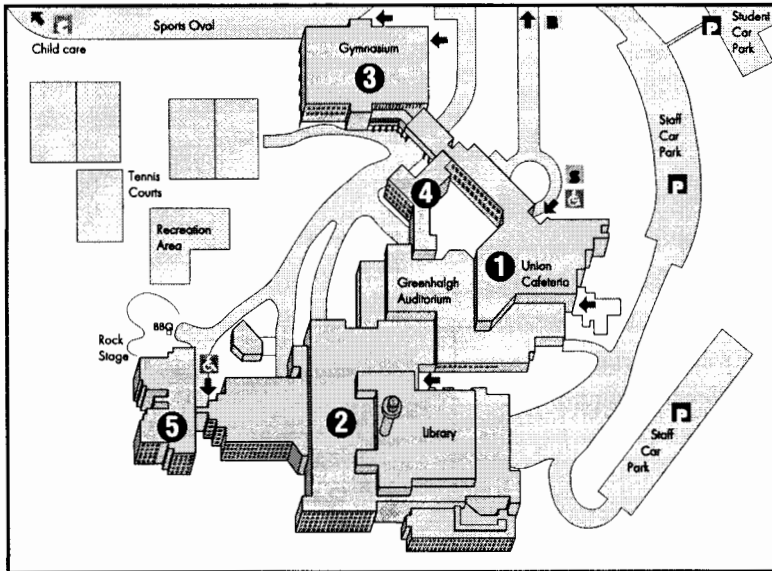
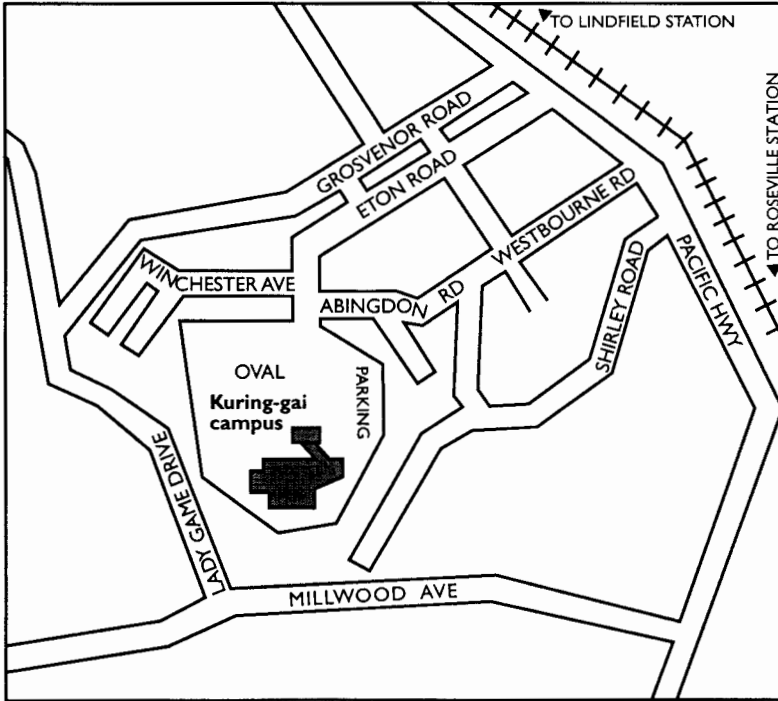

### St Leonards campus

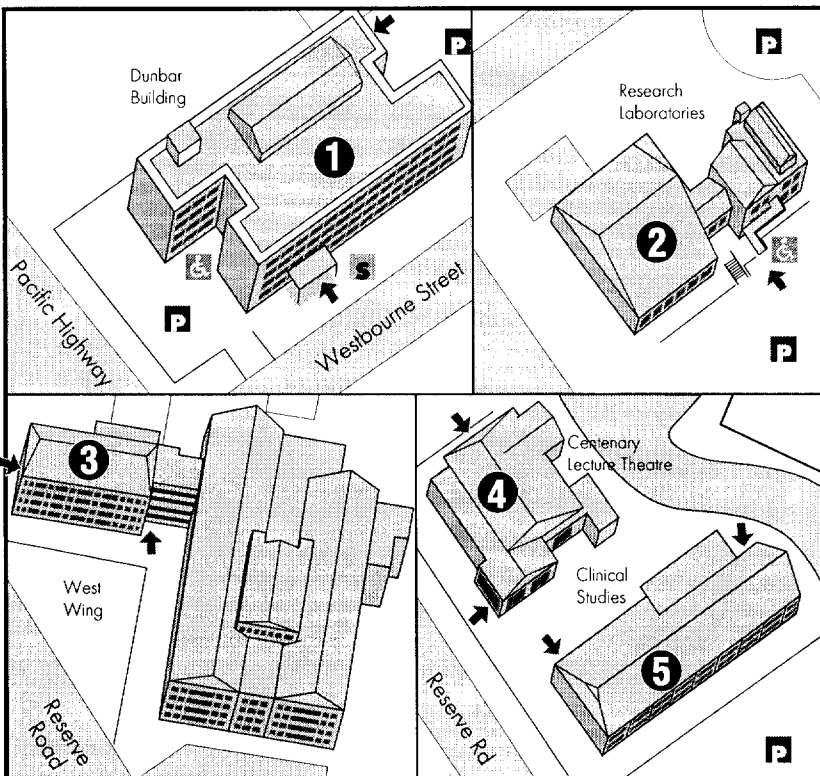
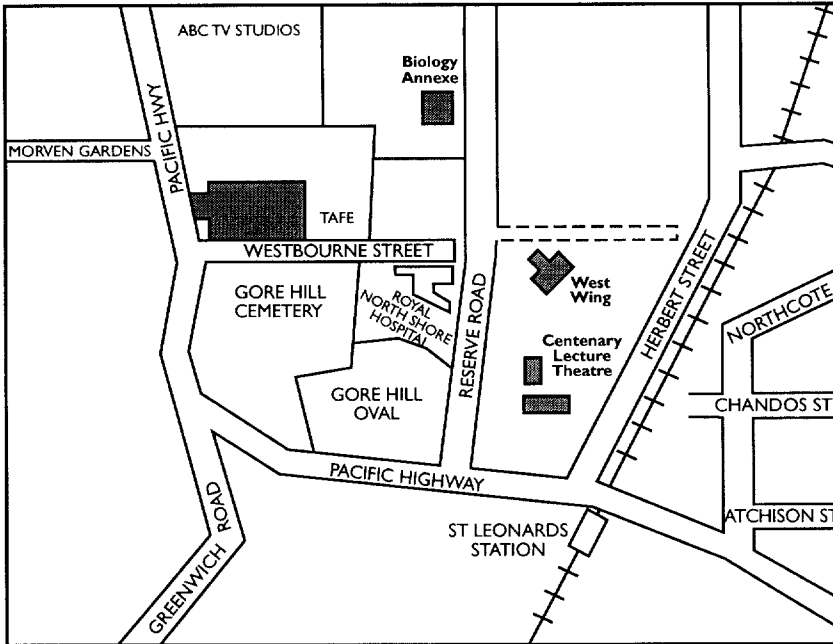

## APPLYING FOR UTS COURSES

### Undergraduate

Applications for the majority of those undergraduate courses which start at the beginning of each year must be lodged through the NSW and ACT Universities Admissions Centre (UAC) between August and October. Please check the application requirements in the *UAC Guide*, as some of these courses close for applications at the end of September. Some courses are also available by direct application to UTS. These are usually courses that are not available to school leavers.

A small number of UTS courses also start in the middle of the year. Applications for these should be made direct to UTS in May.

Contact the UTS Information Centres for more information.

### Postgraduate

Applications for postgraduate courses should be made direct to UTS. For courses starting at the beginning of the year, most applications are open from August to October, but some may have earlier closing dates. For courses

starting in the middle of the year, applications close in May.

Contact the UTS Information Centres for more information.

### Non-award and External Award study

Non-award and External Award study allows individuals and students from other universities to study single subjects at UTS. There are four application periods, and closing dates are different for each of the semesters. Some faculties may have special application procedures which will vary depending on the subjects chosen.

Contact the UTS Information Centres for more information.

### International students

International students need to satisfy the normal UTS entry requirements and be proficient in English. For details on courses, fees and application procedures, contact International Programs.

## UTS INFORMATION CENTRES

Street address	Postal address	Telephone/Fax
<i>City campus</i>		
Foyer, Tower Building 1 Broadway	UTS Information Service PO Box 123 Broadway NSW 2007	Telephone: (02) 9514 1222 Fax: (02) 9514 1200
<i>Kuring-gai campus</i>		
Level 5 or 6, Main Building Eton Road Lindfield	Kuring-gai Student Centre PO Box 222 Lindfield NSW 2070	Telephone: (02) 9514 5555 Fax: (02) 9514 5032
<i>International Programs</i>		
Level 5, Tower Building 1 Broadway	International Programs PO Box 123 Broadway NSW 2007	Telephone: (02) 9514 1531 Fax: (02) 9514 1530

### Email inquiries

Within Australia – [info.office@uts.edu.au](mailto:info.office@uts.edu.au)

International – [intlprograms@uts.edu.au](mailto:intlprograms@uts.edu.au)



## PRINCIPAL DATES FOR 1998

### Autumn semester

#### January

- 2 Release of HSC results
- 9 Formal supplementary examinations for 1997 Spring semester students
- 9 Closing date for changes of preference to UAC from 1997 NSW and ACT HSC applicants
- 16 Final examination timetable for Summer session
- 23 Main round of offers to UAC applicants
- 26 Australia Day – public holiday
- 26 Public school holidays end
- 28 Closing date for changes of preference to UAC for final round offers
- 28-30 Enrolment of new undergraduate students at City campus (and 2-4 February)

#### February

- 2 Last day for continuing students to pay their 1998 service fees
- 2-4 Enrolment of new undergraduate students at City campus (and 28-30 January)
- 6 Final round of offers (UAC)
- 2-13 Formal examinations for Summer session
- 23 Release of results for Summer session
- 5-26 Enrolment of students at City campus

#### March

- 2 Classes begin
- 4-5 Enrolment (External award, Non-award and Exchange students)
- 13 Last day to enrol in a course or add subjects
- 20 Last day to pay HECS
- 30 Last day to apply to graduate in Spring semester 1998
- 31 Last day to apply for leave of absence without incurring student fees/charges<sup>1</sup>
- 31 Last day to withdraw from a subject without financial penalty<sup>1</sup>
- 31 HECS census date

#### April

- 9 Last day to withdraw from a course or subject without academic penalty<sup>1</sup>
- 9 Public school holidays begin
- 10 Good Friday
- 13-17 Vice-Chancellors' Week (non-teaching)
- 14-17 Graduation (Kuring-gai)
- 24 Provisional examination timetable available
- 25 Anzac Day – public holiday
- 27 Public school holidays end

#### May

- 1 Applications available for undergraduate courses where applicable
- 1 Applications open for available postgraduate courses for Spring semester 1998
- 4-15 Graduation (City)
- 15 Examination masters due
- 29 Closing date for undergraduate and postgraduate applications for Spring semester
- 29 Final examination timetable

#### June

- 8 Queen's Birthday – public holiday
- 12 Last teaching day of Autumn semester
- 13-30 Formal examination period (and 1-3 July)

#### July

- 1-3 Formal examination period (and 13-30 June)
- 3 Autumn semester ends
- 3 Public school holidays begin
- 6-10 Vice-Chancellors' Week (non-teaching)
- 13-17 Formal alternative examination period for Autumn semester students
- 20 Public school holidays end
- 24 Release of Autumn semester examination results; two days earlier via UniPhone™
- 27 Formal supplementary examinations for Autumn semester students

## Spring semester

### August

- 3 Classes begin
- 3 Applications available for undergraduate and postgraduate courses for Autumn semester 1999
- 7 Last day to withdraw from full year subjects without academic penalty<sup>1</sup>
- 14 Last day to enrol in a course or add subjects
- 31 Last day to apply for leave of absence without incurring student fees/charges (Spring enrolments only)<sup>1</sup>
- 31 Last day to withdraw from a subject without financial penalty<sup>1</sup>
- 31 Last day to apply to graduate in Autumn semester 1999
- 31 HECS census date

### September

- 11 Last day to withdraw from a course or subject without academic penalty<sup>1</sup>
- 25 Provisional examination timetable available
- 25 Public school holidays begin
- 28 Vice-Chancellors' Week (non-teaching) begins
- 28-30 Graduation (City)
- 30 Closing date for undergraduate applications via UAC (without late fee)
- 30 Closing date for inpUTS Special Admission Scheme applications

### October

- 1-2 Graduation (City)
- 2 Vice-Chancellors' Week (non-teaching) ends
- 5 Labour Day – public holiday
- 12 Public school holidays end
- 16 Examination masters due
- 30 Final examination timetable available
- 30 Closing date for undergraduate applications via UAC (with late fee)

- 30 Closing date for undergraduate applications direct to UTS (without late fee)
- 30 Closing date for most postgraduate courses for Autumn semester 1999 (some courses may have earlier closing dates in September)
- 30 Closing date for Australian Postgraduate Awards, the R L Werner and University Doctoral scholarships

### November

- 13 Last teaching day of Spring semester
- 14-30 Formal examination period (and 1-4 December)
- 30 Closing date for Undergraduate applications via UAC (with late fee)

### December

- 1-4 Formal examination period (and 14-30 November)
- 4 Spring semester ends
- 14-18 Formal alternative examination period for Spring semester students
- 18 Public school holidays begin
- 21 Release of Spring semester examination results; two days earlier via UniPhone™

---

<sup>1</sup> HECS/Postgraduate course fees will apply after the HECS census date (31 March and 31 August or last working day before).

**Note:** Information is correct as at 6 November 1997. The University reserves the right to vary any information described in Principal Dates for 1998 without notice.

# ***Faculty information***

---

## **MESSAGE FROM THE DEAN**

The Faculty of Science comprises several departments in the biological and biomedical sciences and in the physical sciences. It is housed on two campuses – City and St Leonards.

The Faculty offers 26 undergraduate degree programs, Master's and PhD programs by research, and several graduate coursework programs including seven Master's degrees by coursework. The Faculty also provides teaching for several other faculties of the University. The Faculty ensures that its educational services are available to students from a diversity of backgrounds and offers full- and part-time study patterns that facilitate progress through its courses.

Teaching innovations in the Faculty include an inquiry/discovery approach to laboratory teaching in several areas, increasing use of multimedia technology and extensive use of computers for modelling and simulation.

The Faculty is proud of its strength in research. It wins almost half of the competitive grants awarded to the University and is a major contributor in three Cooperative Research Centres. Much of the Faculty's research is focused on the activities of its research centres and units. This concentration of research has enabled the Faculty to significantly improve the quality of its laboratories and its major equipment in recent years, to the obvious benefit of our students.

If you are a new student I welcome you to the Faculty, and wish you a challenging, inspiring and rewarding stay with us as you undertake your studies. The graduates you will join in a few short years have a very high reputation with Australian industry and the professions.

***Professor Tony Moon***  
**Dean**

## **FACULTY MISSION STATEMENT**

The purpose of the Faculty is to provide the highest quality graduate and postgraduate professional education and training to meet the needs of Australian industry and science; and to engage in research and allied professional scientific activities to bring economic and social benefits to the Australian and international community.

Its vision is to become a leading science faculty, recognised nationally and internationally for the quality of its teaching, research and community service programs. The Faculty has developed its reputation by producing Bachelor's and higher degree graduates who meet the needs of Australian industry and the professions, and by establishing strong links with Australian industry through cooperative education, research and development.

## FACULTY OF SCIENCE

The Faculty of Science has established a sound tradition of providing quality teaching, research and consultancy.

The Faculty consists of several departments in biological and biomedical sciences as well as in physical sciences. The departments in the physical and health sciences as well as the main Faculty Office are located at the City campus. The St Leonards campus houses the departments in environmental, biological and biomedical sciences, and a Dean's office. The Department of Health Sciences works on both campuses while operating the College of Traditional Chinese Medicine on Harris Street and running the Acupuncture Clinic on Broadway.

The Faculty provides high quality professional education in physical, biological and biomedical sciences, and engages in high-level research, scholarship and other community service activities in support of the UTS mission, with a view to bringing social and economic benefit to the Australian community.

The Faculty offers a number of graduate and Honours degree programs developed to produce graduates for professional and vocational practice with an ability to continue their studies by research and to contribute to the knowledge-base of their scientific discipline. Bachelor of Science and Honours programs are offered in applied chemistry, applied chemistry/forensic science, applied physics, biomedical science, biotechnology, materials science, medical science, environmental biology, environmental and urban horticulture, earth and environmental science with honours in either geoscience or environmental science. Bachelor of Health Science and Honours programs are offered in acupuncture and Chinese herbal medicine. Professional Experience is offered as an optional and additional component of all of the Bachelor of Science degree courses and leads to the award of a Diploma in Scientific Practice.

The Faculty is involved in the teaching of science to other faculties, including Engineering and Nursing. The Faculty is also involved in offering six joint undergraduate degree programs:

- The Bachelor of Science in Science Education program was first introduced at UTS in 1991 and is offered jointly with the Faculty of Education. The course is

unique in that it combines three-and-a-half years of full-time academic studies in science and education together with six months of industrial training in a scientific discipline plus periods of teaching practice. The combination of academic subjects together with the industrial training means that secondary school teachers will be far better equipped to advise students on career options in industry.

- The BSc LLB degree course is offered in conjunction with the Faculty of Law. In order to qualify for separate awards in science and law, students are required to select an area of specialisation in science so that they can proceed to more advanced studies and thereby obtain recognition in relevant professional fields. Graduates from the course will be qualified for professional practice as either scientists or lawyers and especially in areas where a knowledge of both disciplines is desirable.
- The BMedSc LLB double degree course, newly introduced in 1998, is similar in structure to the BSc LLB course but with a specialisation in medical science. Graduates will qualify for professional practice in either field but may expect to be in most demand in those areas of law in which a knowledge of medical science is a particular advantage or, conversely, in areas of science such as the biotechnology or pharmaceutical industries where a knowledge of the law has special value.
- The combined degree Bachelor of Science/Bachelor of Arts in International Studies, newly introduced in 1998, provides students specialising in Science with additional practical skills, in particular those that increase awareness of their international contexts through providing the opportunity to acquire knowledge and understanding of a language and culture other than English. Students are required to select an area of specialisation in science and a region or country of specialisation within the International Studies program. The length of the Bachelor of Science/Bachelor of Arts in International Studies course is five years full-time (six years for Forensic Science students) which includes one year of In-country study. Graduates may work as professionals in their area of scientific expertise particularly in specialist positions where an understanding of a particular culture may be highly desirable.

- The combined degree Bachelor of Health Science in Acupuncture/Bachelor of Arts in International Studies provides acupuncture students with greater exposure to, and understanding of, China's culture and a working knowledge of Chinese. The program will make it easier for acupuncture graduates to practise outside Australia.
- The Bachelor of Applied Science in Physics/Bachelor of Engineering in Electrical Engineering/Diploma in Engineering Practice course integrates four-and-a-half years of full-time academic study in applied physics and electrical engineering with two semesters of paid industrial experience. Graduates may work in professional practice in high technology industries or in research and development. Career areas may include medical technology, energy technology, applied optics, communications, computer modelling, electromagnetics, technology management, materials analysis and instrumentation and control.

In the postgraduate area, the Faculty offers PhD and Master's degrees (by thesis), Master of Science programs (by coursework), Graduate Diplomas, and Graduate Certificates. Prospective students should discuss possible topics of research with the head of the appropriate department in the first instance. The research programs may be carried out on either a full-time or a part-time basis and it is permissible for part-time students to undertake a portion of their research at a site external to UTS, provided an appropriate external supervisor can be appointed. Details of current research in progress can be obtained from the office of the Associate Dean (Research Programs).

The Faculty has a strong record of research and development, essential to the strength of both undergraduate and postgraduate programs.

Competitive research funding is obtained across a wide range of areas of expertise. The Faculty wins almost half of the competitive grants awarded to the University and is a major contributor in three Cooperative Research Centres, namely Cardiac Technology, Aquaculture, and Australian Centre for Renewable Energy. Much of the Faculty's research focuses on the activities of its research centres and units, including the Centre for Ecotoxicology (run jointly with the Environment Protection Authority), the Institute for Coastal Resource Management, the Centre for Materials Technology, the National Centre for Groundwater Management and the Centre for Biomedical Technology. This concentration of research has enabled the Faculty to improve significantly the quality of its major equipment in recent years, to the obvious benefit of its students. In research, the areas targeted for future development include forensic science and environmental management.

In the development of all of the above programs the Faculty is assisted by appropriate advisory committees with members drawn from the wider community. The courses are regularly reviewed to ensure currency and relevance to industrial and commercial practice.

The Faculty has always maintained strong links with industry. Staff members maintain contact with industry by undertaking appropriate research and consulting activities. For all of the Bachelor of Science degree courses students have the option to spend a further 12 months working in a relevant industry. This leads to the additional award of a Diploma in Scientific Practice. The Faculty provides assistance to students in finding these paid professional experience positions.

Most programs referred to above are available on either a full-time or part-time basis or a combination of both these attendance patterns.

## UNITS WITHIN THE FACULTY

Much of the Faculty's research is focused in the activities of several research centres, institutes and units. The Faculty also runs the College of Traditional Chinese Medicine and administers two clinics. Details of the centres, institutes and the College of Traditional Chinese Medicine can be found on the following pages. The units in the Faculty are as follows:

### Immunobiology Unit

The Immunobiology Unit was established in 1989 as a multidisciplinary laboratory undertaking research into basic and applied aspects of the immune system. The Unit pursues active research and postgraduate training programs in the fields of toxinology, antibody engineering, lymphocyte development and malignancy, and immunophylogeny. These research projects are supported by grants from external agencies such as the ARC and NHMRC, and by commercial research contracts with industry partners.

### Molecular Parasitology Unit

The Molecular Parasitology Unit was established in 1991 as a laboratory investigating evolution, taxonomy, differentiation and diagnosis of parasites based on molecular methods. Its research objective is to generate and compare gene sequences. The Unit has an international reputation in this area, and trains visiting overseas researchers and students, in addition to providing high quality postgraduate training in molecular biology research to local scientists and students. The Unit is multidisciplinary, relying on molecular techniques developed, used and taught in the Department of Cell and Molecular Biology, and mathematical analyses and computing practices undertaken in the Department of Environmental Sciences.

### Molecular Genetics Unit

The Molecular Genetics Unit was established in the Department of Cell and Molecular Biology as a focus for basic and applied molecular biology research. Research areas include X chromosome inactivation, gene therapy (diabetes), multidrug resistance (prokaryotic and eukaryotic) and gene regulation of plant senescence and stress.

### Psycho-Oncology Unit

The Psycho-Oncology Unit (formerly the Neurobiology Unit) was established in 1973 within the Department of Cell and Molecular Biology. It now carries out research into the effects of emotional states on cancer recurrence in early and late stage breast cancer using cognitive behavioural therapy in groups. The unit is funded through donations by the community and business sectors.

### College of Traditional Chinese Medicine

The UTS College of Acupuncture was established in 1994, founded upon the experience and educational expertise of Acupuncture Colleges (Australia). With 25 years' experience, Acupuncture Colleges (Australia) previously offered diploma and Bachelor's programs accredited by the New South Wales Ministry of Education. The decision to transfer acupuncture education to the University was in accord with the growth in acceptance and use of acupuncture in Australia, and the need to provide a standard of education at a level expected by the community.

In 1995, the College was incorporated into the Faculty of Science as part of the Department of Health Sciences. In 1997, the College of Acupuncture was renamed the College of Traditional Chinese Medicine, offering undergraduate programs in both acupuncture/moxibustion and Chinese herbal medicine, the two major strands of Traditional Chinese Medicine (TCM).

The Faculty of Science offers a three-and-a-half year full-time Bachelor of Health Science degree in Acupuncture and another three-and-a-half year full-time Bachelor of Health Science degree in Chinese Herbal Medicine. Facilities do not yet exist for offering these courses on a part-time basis. In addition to the undergraduate degree, the Faculty offers a Master of Health Science in Traditional Chinese Medicine (by coursework) that provides graduate education in either acupuncture or Chinese herbal medicine to qualified applicants who wish to extend their knowledge to incorporate another branch of Chinese medicine into their clinical practice. Studies leading to a Master of Science by research are also available.

The Faculty administers two clinics, one offering acupuncture services and the other Chinese herbal services, to the community.

These clinics also play a major role in the clinical education of acupuncture and Chinese herbal students. One clinic operates from a shop on Broadway (acupuncture), while the other operates from Level 4, 645 Harris Street (Chinese herbalism).

In the development of all programs, the Faculty is assisted by advisory committees comprised of members of the education, health and acupuncture professions. The courses and specific subjects are also under ongoing review and development to ensure their relevance to traditional Chinese medical practice.

The Faculty benefits from close links with the Universities of Traditional Medicine in China and the TCM Unit at the Victoria University of Technology. Through an affiliation with the Guangzhou University of Traditional Chinese Medicine, undergraduate students are offered an optional one-month hospital internship in China which carries credits towards the clinical component of the degree programs.

Students entering either the Bachelor of Health Science in Acupuncture or the Bachelor of Health Science in Chinese Herbal Medicine are eligible to apply for places in the combined degree: Bachelor of Health Science (in Acupuncture or Chinese Herbal Medicine)/ Bachelor of Arts in International Studies (Mandarin major). Academically selected students enter this program at the beginning of their third year. The combined program extends the course length to five-and-a-half years, one year of which is spent in China studying language, culture and TCM.

Students of the College of TCM are strongly recommended to read the 'Code of Conduct for students of the College of Traditional Chinese Medicine' under the section on 'Information for Students' in this Faculty of Science Handbook.

All course inquiries should be directed to: Mr Bob Hayes, at the UTS College of Traditional Chinese Medicine, 4/645 Harris Street, Ultimo 2007, telephone (02) 9514 2500.

## CENTRES AND INSTITUTES

### Centre for Biomedical Technology

The Centre for Biomedical Technology is a multifaculty and interdisciplinary research centre with a network of researchers from the Faculties of Science, Engineering, Mathematical and Computing Sciences, Nursing and Business. It integrates the University's diverse expertise and resources to enhance the scientific and technological base for the biomedical technology industry, government and health care providers. It aims to facilitate and coordinate biomedical technology research, promote continuing education in the field, develop medical devices and provide consultation to the biomedical technology industry. Research programs are in the areas of cardiac electrophysiology and technology, medical imaging, biomathematical modelling, medical instrumentation, diabetes and the nursing-technology interface. The Centre is a key participant in the Cooperative Research Centre for Cardiac Technology.

The Centre provides expertise and facilities for postgraduate training and research programs for postdoctoral researchers, academic staff and students. Staff conduct teaching in medical physics, bioengineering, biomathematics, clinical measurement and physiology. The Centre offers Master's (by thesis) and Doctoral degree programs.

### Centre for Ecotoxicology

This Centre is a joint enterprise of UTS and the NSW Environment Protection Authority (EPA), and is located in the St Leonards campus of the University. The aims of the Centre are to promote education, research and information transfer in the field of ecotoxicology. This is a newly emerging discipline that has arisen as a result of the dependence of modern society on the use of chemicals. It is a meeting point of chemistry and biology – the study of the impacts of chemicals and mixed effluents on communities in affected areas.

The Centre coordinates research programs at Honours, Master's and Doctoral levels, and also offers Master's and Graduate Certificates by coursework in ecotoxicology. Teaching and research supervision involve a collaboration of both the UTS and EPA staff. The research work

of the Centre involves consultation with industry and government in identifying areas in which investigation is needed on the impact of chemicals on native flora and fauna under Australian climatic and other environmental conditions. A foundation of scientific knowledge is required in order to ensure the development of appropriate environmental quality guidelines for this continent.

The University arm also offers an independent investigative and testing service for industry, through the UTS consulting company, Insearch Limited.

### **Centre for Materials Technology**

The Centre for Materials Technology offers expertise, education, instrumentation and innovation in the areas of materials science and engineering. Its aim is to offer to industry and government a collaborative and multi-disciplinary approach to research, development, manufacturing and problem solving for the technological and economic benefit of Australian industry.

The main functions of the Centre are to assist staff teams to obtain government and industrial research grants; make facilities and expertise available for industry and government; establish postgraduate research scholarships and research assistantships; coordinate multidisciplinary research investigations; undertake consultancy; assist relevant professional institutes to organise conferences and seminars; present regular postgraduate and postcertificate courses; present in-house high-tech training courses for industry; present research and development seminars; and to develop products and devices of high quality. The Centre has nine projects involving carbons, cements, composites, nanoengineering, fuels, electroactive sensors, lighting, alumina and dental implants. The Centre has recently been successful in obtaining external funding for research into conducting polymers, applications of piezoelectric devices and alumina and synthetic fuel production.

### **Centre for Science Communication**

The aims and objectives of the Centre for Science Communication are to promote the public understanding of science and technology; organise and develop undergraduate and postgraduate courses in science communication; organise information

programs on science and technology for schools; coordinate research into science communication; and promote UTS as one of Australia's leading technological institutions.

There are several programs under development, including the 'Horizons of Science' forums for the media, communication courses for undergraduate and postgraduate students, production of booklets on science for high school students and teachers and media briefings for scientific organisations. The Centre is located in Building 2, City campus.

### **Cooperative Research Centre for Aquaculture**

The Cooperative Research Centre for Aquaculture commenced operating early in 1994 and includes participants from six universities (including UTS), seven other research institutions and a number of commercial groups. The Federal Government has funded six of the research programs and UTS is involved in two of them, namely the Health Protection and Maintenance Program and the Production Efficiency and Environmental Management Program.

The Directorship of the Cooperative Research Centre is located at Broadway in the City campus. It is linked with the University through the Office of the Pro-Vice-Chancellor (Research), the Research Office and several units throughout the University, such as the Library, the External Relations Unit and the School of Computing Sciences.

The CRC's Health Protection and Maintenance Program has been redesigned and now comprises two major multi-institutional projects. One of these is lead from the UTS Department of Cell and Molecular Biology, and also involves the University of Tasmania, the Tasmanian Department of Primary Industries, and the salmon industry. It is aimed at the development of novel generic technologies for fish vaccines.

The Production Efficiency and Environmental Management Program includes a large collaborative project between CSIRO, Australian Institute of Marine Science, James Cook and Queensland Universities and UTS, as well as other research groups and several prawn farms. This project covers the analysis, management, effluent control and environmental impacts of ponds used for the intensive farming of prawns.



## **Cooperative Research Centre for Cardiac Technology**

The CRC for Cardiac Technology (CRC-CT) aspires to perform multidisciplinary research of an international rank in the health care sector, with a primary focus on device development. The CRC-CT has an important role in changing the existing research culture in Australia by promoting a recognition of the synergistic effect of collaboration between research and industry groups. The CRC-CT is affiliated with four universities (UTS, University of Sydney, University of Queensland and the University of NSW), with CSIRO, AMLAB International, and the Royal North Shore and Westmead Hospitals.

UTS participants in the CRC-CT include members of the Centre for Biomedical Technology, Department of Chemistry, Materials and Forensic Science, Faculty of Nursing and the Faculty of Engineering.

In its first four years of operation, the CRC-CT has established three internationally competitive project groups whose research outcomes have led to significant publications, a sizeable cluster of patents and beyond that, to the development of products with substantial commercial potential.

The Heart Failure project group is developing heart-assist devices and technologies including potential cellular therapy, and diagnostic devices for better management of this chronic condition.

The Biomaterials project group is developing new polyurethanes suitable for long-term implantation as blood vessel grafts, mechanical heart valves, heart pump devices or as leads and electrodes for implantable pacemakers and defibrillators.

The Electrophysiology Mapping and Ablation (EPMA) project group is attempting to better delineate the cause of the more serious heart rhythm disorder ventricular tachycardia and the more common and yet troublesome atrial fibrillation, and to 'cure' them by modifying the abnormal tissue substrate using technologically novel treatment processes.

The CRC-CT offers an extensive training program for PhD students which provides them with industrial experience in a multidisciplinary, multi-site collaborative environment. A number of postgraduate scholarships are available. Vacation scholarships for undergraduate students have proved popular and successful.

The CRC-CT has developed formal relationships with a number of international

universities, which provide opportunities for joint research projects, publications, and exchange of postdoctoral scientists and cardiac surgeons. International links have been established with the University of Nagoya and the National Cardiovascular Centre in Osaka, Japan and the University of Liverpool.

## **Institute for Coastal Resource Management**

The Institute for Coastal Resource Management is an interfaculty network of education, research and consultancy teams within the University. It integrates the University's diverse expertise and resources in several disciplines including environmental sciences (biology, chemistry, geology), environmental law, economic and sustainable development, planning, and management. This combination is unique within Australia for coastal resource management studies. Currently, staff from the Faculty of Science, Graduate School of Business, Faculty of Engineering, Schools of Leisure and Tourism Studies, Law and Building Studies are involved. The Institute is located on the St Leonards campus.

The Institute aims to offer interdisciplinary professional courses and conduct relevant research in the coastal zone for industry, government and the community, identify problem areas and solutions, and enhance the community awareness of the coastal zone and its problems. These developments, solutions and expertise will be exported to neighbouring countries in the Pacific region and other collaborative links will be developed in North America and Europe.

Through the University the Institute is linked with several overseas and national universities. These linkages are expanding. Students may complete work at those institutions and gain credit.

## **Cooperative Research Centre for Renewable Energy**

The Cooperative Research Centre for Renewable Energy commenced operation in late 1996. It is incorporated in Western Australia. UTS is one of eight universities which are members of this CRC. The UTS participants include members of the Faculty of Engineering, the Department of Applied Physics and the Faculty of Design, Architecture and Building and the Centre for Materials Technology. The CRC's work ranges over many areas of renewable energy technology

including solar cells, solar thermal systems and energy efficient technologies. The UTS contributions are predominantly in the area of energy efficiency including novel electric motors, energy efficient glazing, and new daylighting and lighting systems. There is also a major contribution to the development and assessment of computer software for use in the design of energy efficient buildings.

The CRC will have a major impact on Australia's contribution to technologies which will reduce greenhouse gas emissions and will open up a range of new industries which are anticipated to generate considerable income for the country, and a wide range of new employment opportunities. The UTS participants are constructing special systems for the accurate specification of building components as needed for complex computer models that address lighting and energy flows in buildings. There are strong links with companies in Sydney and Canberra.

### **National Centre for Groundwater Management**

The National Centre for Groundwater Management is a joint enterprise between the Faculties of Science and Engineering, with the general aims of researching groundwater problems of strategic national importance, coordinating and developing postgraduate courses and continuing education programs, and liaising with industry.

The Centre is recognised by the Federal Government through the Land and Water Resources Research Development Corporation as a National Centre for research and consultancy training in groundwater and environmental applications.

In addition to PhD and MSc (research) degree programs in groundwater, the Centre offers two courses as a collaborative effort between the Faculty of Science and the Faculty of Engineering, namely, the Master of Science in Hydrogeology and Groundwater Management and the Graduate Diploma in Hydrogeology and Groundwater Management. There are flexible arrangements for each program: part-time, full-time and distance mode. Further details are given in the section on postgraduate courses.

For inquiries please contact Professor Michael Knight, Director, National Centre for Groundwater Management, Room 1/1715, telephone (02) 9514 1984, fax (02) 9514 1985, email [groundwater.management@uts.edu.au](mailto:groundwater.management@uts.edu.au)

## **INFORMATION FOR STUDENTS**

Students in the Faculty of Science are strongly encouraged to read the handbook and the 1998 *UTS Calendar* (particularly Chapter 2 'General Information') for advice on student administration matters. The *UTS Calendar*, the official information guide to UTS courses, rules and regulations, may be purchased from the Union Shop on Level 3 of the Tower Building of UTS, City campus. Copies of the *UTS Calendar* are available for perusal at the UTS Library and at the student information offices at Kuring-gai (Student Centre is on Level 6, with an inquiry counter in the foyer area on Level 5 of the Kuring-gai campus) and Broadway (the foyer area, Level 4 of the Tower Building, City campus). There will also be copies of the *UTS Calendar* available for viewing in each Department and Faculty Office at both the St Leonards and City campuses. The *UTS Calendar* contains valuable information about the different services available to students, student admission requirements, enrolment, examinations, exclusion, progression, graduation, HECS, Austudy, Abstudy and other important matters.

### **Environment, Health and Safety**

#### **Statement of aims**

The University is committed to providing a safe and healthy workplace for students, staff and visitors and adopting a socially responsible approach towards protecting and sustaining the environment. It aims to be at the forefront of environment, health and safety practice in higher education.

To this end UTS will:

- prevent or control hazards that could result in personal injury or ill-health;
- manage accidents and incidents that do occur in order to minimise harmful effects and to prevent recurrence;
- promote safe and environmentally sound practices among the UTS community;
- carry out its teaching, research and organisational activities in ways that protect the environment from harmful effects;
- integrate environment, health and safety issues into its curricula and research as appropriate.

## Faculty of Science Environmental, Health and Safety Action Plan

The Faculty of Science Environmental Health and Safety (EHS) Action Plan, provides details of EHS responsibilities and procedures. Copies of the Action Plan are available in laboratories and in the Department and Faculty offices. Relevant information is also displayed in laboratories and on noticeboards.

Always remember that health and safety is everybody's responsibility. Everyone is required to demonstrate a responsible attitude towards environmental, health and safety issues, and especially their impact on laboratory and field work.

You must know how to report emergencies, accidents and incidents, and what action you should take to minimise or eliminate hazards.

Never do anything without considering the risks of your actions in relation to the health and safety of others and, if you are intending to carry out any unfamiliar work which might pose a health, safety or environmental risk, always make sure you get appropriate information, advice or instruction before you start.

By following these simple rules, we shall make the Faculty of Science a safer and healthier place in which to study and work.

### Statement of good practice and ethics in informal assessments

The 'Statement of good practice and ethics in informal assessments' is especially included here because the statement is taken very seriously by the Faculty and we encourage you, the student, to take it seriously too.

#### 1. Aims of informal assessments

The term 'informal assessment' at UTS is defined as any assessment task other than a final examination that is administered by the Registrar and held in the official UTS Examination Weeks. Such assessment is in no other sense 'informal', especially as it contributes to the final assessment of the student in the subject.

Common forms of such assessment in the Faculty of Science include:

- practical reports
- computer programs
- essays and assignments (including reports of field work)
- tests and quizzes.

The setting and assessing of these tasks is aimed at promoting the following educational aims:

- furthering each student's learning of the subject
- the acquisition of practical skills of laboratory and field work, and their documentation
- providing a means for staff to assess each student's learning
- providing feedback to the student on progress in learning
- providing feedback to staff on the effectiveness of their teaching.

These aims will be subverted if students deceive staff about either the authenticity of results, or the authorship of their written work. Such behaviour is unethical, unprofessional and completely unacceptable. Within the Western tradition of scholarship it is regarded as a serious academic offence.

It is recognised that students may sometimes find themselves in positions of extreme stress, for reasons of illness or misadventure, when malpractice may seem tempting. In such circumstances, however, other solutions are available, for example, seeking extra time for the submission of an assignment, accompanied by a medical certificate and/or other compelling explanation.

#### 2. Unacceptable behaviour

Cheating in all its forms is unacceptable behaviour, **and cannot be condoned**. Cheating is a breach of the University Rules. Examples of cheating include:

##### 2.1 Outright lying

This is never acceptable under any circumstances. Remember that lying, in science, includes inventing or falsifying results.

##### 2.2 Plagiarism (copying)

The *Oxford Dictionary* defines plagiarism as the taking and using of another person's thoughts, writings or inventions as one's own. It includes unacknowledged quotations from other authors (books, journals, fellow students), or the copying out, perhaps with changes intended to disguise, of slabs of other people's work. Don't copy!

##### 2.3 Collusion

Collusion is a fraudulent, secret understanding between two or more people to deceive, for example, in 'fixing' results, or doing one essay

together and rewording it slightly to pass it off as two independent efforts.

## 2.4 Use of unauthorised material or equipment

Only equipment or material specified by the coordinating examiner may be used by a student during examinations, class tests and quizzes. Don't write on rulers, calculator cases etc.!

Don't cheat! Don't even think of cheating!

## 3. Acceptable practices

### 3.1 Acknowledging sources – referencing

Whenever any other person's work is used in the formulation of a written piece of work, it must be clearly indicated where the source of the information lies. The 'other person' could be a published or unpublished author, your lecturer, or one of your fellow students. Consult the various guides to writing assignments that are held in the library (and any that your lecturers may provide). As you prepare the assignment, keep a detailed running record of your references in a notebook, and use a standard referencing system e.g. the Harvard system. Often references cannot be found again later.

### 3.2 Collaboration

In many cases, experiments and other means of data collection require students to cooperate. Some assignments may involve an ideas-gathering stage followed by the writing-up phase.

While collaboration is normally encouraged in the developmental and experimental stages, **final data analysis and interpretation and writing-up** must be strictly your own effort (except in any exceptional circumstances that would have to be spelt out in detail by your lecturer).

## 4. Guide for good practice in written work

(Adapted from the statement prepared by the Faculty of Humanities and Social Sciences.)

### 4.1 Writing essays or assignments

Developing the ability to express yourself and argue clearly and in your own words is an important part of your university studies. Students are often confused, however, about just what is expected of them in written work: on the one hand, they are asked to present their own original ideas and arguments yet, on the

other, they are told to use and take account of ideas, concepts and theories etc., in the material they read. In fact, an important element of a well-written piece of work is the way that a student meets these two, apparently conflicting, demands.

### 4.2 Originality

'Being original' in an essay, for instance, **does not** mean that you have to think up your own theories and concepts etc. Rather, it refers, in part, to the way you make use of – by critiquing, analysing, evaluating, synthesising, exemplifying, instancing – the ideas, theories, evidence etc. of other writers or of experimental or secondary data (e.g. census statistics) in constructing a coherent and plausible argument.

### 4.3 Arguing a case

Strictly speaking, an 'argument' refers to the reasoned advancement of a number of propositions leading to a particular conclusion. In an essay, it means that having read and considered the relevant literature, and on the basis of this and any other appropriate evidence, you come to a conclusion about the question. In writing the essay, you set out the argument, or a series of arguments, to support that conclusion. In doing so, you draw on relevant ideas etc. from your reading, using them to support your argument. In cases where experimental data form the basis of the written work, your task may be to argue the case of how the data support or falsify a hypothesis.

Whether you are asked to argue, discuss, evaluate, compare and contrast, analyse, critique, consider etc. **you are still being asked to mount a reasoned argument**, in one form or another, leading to a conclusion based on an evaluation of all the evidence presented in your reading or provided by the data. For example, some essay questions may ask you to discuss or evaluate two conflicting arguments; in this case you have to decide – on the basis of the arguments themselves, any other evidence, and perhaps with the help of what some other writers say – which is the stronger or more adequate of the two and then argue that, giving evidence in support.

In a sense, you could think of writing an essay, assignment or report (some of which might require different formats) rather like designing and erecting a building. All the possible and available building materials (bricks, timber, concrete, steel, roofing etc.) would be equivalent to all the reading you have done or experimental data you have acquired. You

certainly cannot just throw a stack of materials on to a block of land and expect them to form the building. Rather, you would need to, firstly, get a general idea of the sort of building that is appropriate by considering all the relevant factors (such as size and lie of the land, accommodation required and building restrictions); secondly, design a structure which takes all of these factors into account, selecting materials to hold up the structure and rejecting those which would not. In a similar way you need to think carefully about all the information you have and decide what is relevant and what you can generally conclude from it; then design or plan it into a coherent and cogent argument supporting that position.

The actual argument (the design) is your original contribution; the support for that argument comes from all the data, ideas and theories etc. you considered and the evidence used (the materials). Hence, it is the way you **critically analyse, evaluate, select and synthesise information and use it in your argument** which is important in the work. You do not create something totally new, nor do you merely throw together other people's ideas. Do not make the mistake of thinking that it is sufficient for you to merely compile into some coherent order other people's referenced ideas etc. – the bulk of the essay has to be your own work.

### Remarking of Assessment Items

Occasionally, you might not be clear about why you received a lower than expected mark, or you might feel that your work has not been fairly assessed.

Initially, you should discuss the matter with the marker or Coordinating Examiner (CE) concerned. Such discussions are part of routine academic procedure by which you receive advice, clarification and feedback about your performance.

Usually, the result of such a discussion will be either:

- (i) the marker or CE will satisfy you that the mark is fair; or
- (ii) you will satisfy the marker or CE that the item was not fairly marked. For example, the marker or CE might have misread a section of your paper. In such cases, the marker or CE will adjust the original mark accordingly.

Sometimes, however, agreement cannot be reached. For example, you might consider that the point of view of the marker or CE does not

allow a disinterested assessment of a particular item. In these cases, you may request that the item be re-assessed by a second marker.

### Code of Conduct for students of the UTS College of Traditional Chinese Medicine

**Rule 2.4.2** of the University states: 'Whilst on the premises of the University or engaged in any activity related to their study at the University, students shall comply with any reasonable directive given to them by an officer of the University, and shall maintain an acceptable standard of conduct'.

**Rule 2.4.4** of the University states: 'Where the Responsible Academic Officer, in consultation with the appropriate External Supervisor (if any), considers that a student so assessed is not ready to proceed with or is unsuitable to continue any part of the required professional experience on its scheduled commencement, the Responsible Academic Officer may defer or re-schedule the student's participation.

The Responsible Academic Officer must advise the students, in writing, of the decision within three business days of making it.

Where the deferral of a student's participation in any part of the required clinical education program would have the effect of preventing the student from continuing his/her course, the Responsible Academic Officer may refer the matter, with appropriate recommendation, to the Vice-Chancellor, who shall take such action as he/she deems appropriate.

The Vice-Chancellor must advise the student in writing of the decision within three business days of making it.'

In addition to Rule 2.4.2. and 2.4.4 students are required to sign an agreement to observe the UTS College of Traditional Chinese Medicine Code of Clinical Conduct. This agreement is an undertaking to observe clinical policy and procedures, to maintain a duty of care to patients and fellow students, and to demonstrate an acceptable level of professional conduct.

#### Clinic dress

The high neck, shoulder buttoning, white, 'dentist' style jacket has been approved as the College's regulation clinical dress for students. Students not dressed in the approved clinical style will not be permitted to attend the clinic session. Students are also required to wear one colour (white, black, brown, navy or grey) shoes in a 'closed' style, with a plain (not

patterned) skirt or trousers in a conservative colour. Sneakers, runners, sports shoes and jeans are not acceptable clinic wear. All clothing must be clean.

All visible jewellery such as rings, ear-rings, face and body piercing rings or studs, bracelets and anklets must not be worn in the clinic. Long hair should be tied back neatly and must look clean and tidy. If nail polish is worn it should be clear or in a pale, natural shade and unchipped. It is recommended that nails are kept short, clean, and natural. Heavy perfumes should not be worn.

Name tags must be worn by all students in the clinic. Students without a name tag may not attend patients.

The standard of cleanliness and the general appearance of students attending College clinics is subject to the approval of the individual practitioner-in-charge or clinic manager. A student who does not meet the required standards may be refused permission to attend their rostered clinic session.

## **College of Traditional Chinese Medicine Policies**

### **Discrimination**

In line with State and Federal anti-discrimination legislation, UTS has a policy of equal opportunity and non-discrimination. This policy is not only applied to students and staff but also to community services. Students should be aware that the patients of the University's clinical services are included, and that anti-discrimination laws must be observed.

### **Confidentiality**

All matters pertaining to patients are confidential. It is unethical to discuss any patient outside the treatment situation. Patient cards and records must not be removed from the clinic and must be stored in locked files.

### **Recording patient information**

Details pertaining to the health and medical history of a patient must be recorded on the patient's clinical record card. Sometimes patients confide personal histories that do not have a primary bearing on their health and which they request should not be recorded. In such instances the patient's wishes should be respected. If the disclosure has a bearing on the primary condition of the patient, or will be a significant factor in their response to treatment, it must be recorded. The patient

should be advised of this requirement and given the option of seeking treatment elsewhere.

### **Patient records**

If a student is asked to treat or to care for a patient, it is the student's responsibility to familiarise themselves with the patient's current condition and to check the patient's clinical records. It is not the responsibility of the clinical manager or the supervising practitioner, although they may advise the student, at their own discretion, of any issues that they deem to be important.

### **Patients on medication and/or attending another practitioner**

It is unethical to comment on any course of treatment or medication provided by another practitioner, or to advise in any manner on a course of treatment provided by another practitioner. All decisions regarding therapeutic choices belong to the patient and, even if a patient asks for advice on the appropriateness, or otherwise, of a therapeutic procedure, it is not acceptable for a student or student/practitioner to comment on matters outside their area of expertise.

### **Refusal of services**

Practitioners and students have the right to refuse TCM services to patients who are drunk, under the influence of mind-altering drugs, abusive, or who exhibit antisocial behaviours. They also have the duty to refuse to carry out services that are illegal, or that they believe have the potential to endanger the health of the patient.

### **Practicums**

Students during practicums in acupuncture, moxibustion, treatment techniques and massage will be required to carry out therapeutic and diagnostic procedures on fellow students. These practical sessions and workshops are under the supervision of a practitioner and all standard procedures and infection control measures must be observed. Students who decline to participate in giving and receiving treatments in practicums will be unable to complete these subjects and will therefore be unable to complete the course.

### **Student Health and Welfare**

It is important that students, especially those entering a healing profession, should maintain good health and general well-being during their studies. The University has a Student

Health Service that offers both health care and counselling services.

Students will be participating in the University's acupuncture or Chinese herbal medicine clinics as observers, assistants and, in their final year, as student practitioners. It is not appropriate for anyone with an infectious condition to work closely with patients. Should students be suffering from any temporary, communicable disease they must advise their clinical supervisor. Students who believe that they may be coming down with a cold, or some minor ailment, are advised to provide, and wear, a surgical mask to protect patients and fellow students from infection.

Students who have HIV or hepatitis infection must be aware of their duty of care to staff, other students, and patients during clinical practice.

### **Advice from the NSW Department of Health**

'The Department, bearing in mind its recommendations to the general community, would hope that all students were adequately immunised against poliomyelitis, diphtheria and tetanus in childhood. They should have had a booster of Sabine vaccine against poliomyelitis and a booster of Adult Diphtheria Tetanus Toxoid (ADT) at about 25 years of age. In addition, persons particularly involved in health services would be wise to have had a Mantoux test and, if seronegative, to have had BCG vaccination (for tuberculosis).'

The guidelines of the College in relation to hepatitis B and health care workers and students indicate the need for hepatitis B immunisation before contact with blood/body fluids and state that it is their obligation to know their current hepatitis B status.

### **Hepatitis B inoculation and Mantoux testing**

Students entering the course are advised that, for their own protection, they should contact the Student Health Service at the City campus to arrange for a Hepatitis B inoculation. These are available at a minimal cost to all acupuncture students. Immunisation against Tetanus and Tuberculosis is also recommended for your protection.

Information regarding Mantoux testing is also available through the Student Health Service. The Student Health Service can make individual or group arrangements for students to receive anti-Hepatitis B virus and anti-

Tetanus vaccinations at any time. The Service is also able to offer advice on anti-Tuberculosis vaccination.

Further information on these matters is available from Student Services Health Service, City campus; telephone (02) 9514 1166.

### **External clinical training**

The College office keeps a list of practitioners who have been approved by the University and who are willing to allow students to attend their private clinics for pre-internship levels of clinical experience. Students should contact the practitioner they wish to attend before making application at the College office.

## **Student Support Centres in the Faculty of Science**

### **Chemistry Learning Resources Centre**

The Chemistry Learning Resources Centre was established in 1996 with the support of Faculty Quality Assurance Funds and is located in Room 211 in Building 4 on the City campus. It has a range of resources to support the learning of chemistry by undergraduate students from the Faculties of Science, Nursing, Engineering and Business. Resources available in the Centre include microcomputers equipped with interactive software, videos, models and books. Most of the resources are for first year students but there are also resources for students studying chemistry in the later stages of their degree program. The Centre is open each weekday during semester. Further information may be obtained by visiting the web pages at <http://www.science.uts.edu.au/depts/chem/clrc/index.html> or by contacting the coordinators Dr Ray Sleet on telephone (02) 9514 1739, fax (02) 9514 1460, email R.Sleet@uts.edu.au or Mrs Rosemary Ward on telephone (02) 9514 1729, fax (02) 9514 1460, email Rosemary.Ward@uts.edu.au

### **Physics Learning Centre**

The Applied Physics Department operates a drop-in Physics Learning Centre on Level 11 of the Tower Building on the City campus. Academic staff members are available at convenient times during the week to assist students with any problems they have associated with their first-year physics studies. In addition to the fixed schedule for personal tutorial assistance, there is a computer laboratory adjoining the Physics Learning Centre in which assistance can be obtained whenever the Physics Laboratory Office is open (normally 9.00 a.m. – 8.30 p.m.). There

are also computer-aided learning programs and simulated textbook problems available for study by all first-year physics students.

For further information contact Associate Professor Peter Logan on telephone (02) 9514 2194, fax (02) 9514 2219, email peter@phys.uts.edu.au

### **Eligibility for Austudy**

Austudy provides financial help to full-time students who meet its income and assets requirements. Application forms and information about Austudy eligibility are available from offices of the Student Services Unit at the City and Kuring-gai campuses. **Students who receive Austudy and decide to drop subjects during the semester need to be aware that to remain eligible for Austudy they must be enrolled in a minimum of 18 credit points or have a HECS liability for the semester of .375.** The only exceptions made are for students with disabilities which interfere with their studies, students who are single supporting parents or those who have been directed by the University to reduce their study load. Student Welfare Officers in the Student Services Unit can assist students who wish to apply for exceptions on these grounds.

## **PRIZES AND SCHOLARSHIPS**

Prizes and scholarships are awarded each year to students in the Faculty for meritorious work. These are made available through the generosity of private individuals and public organisations. They are offered each semester, annually or biennially. In rare instances, a prize or scholarship will be offered only when funds permit. Most prizes and scholarships are offered subject to the provision that they will be awarded only when a student has attained a mark or level of achievement considered by the Faculty Board to be sufficiently high. In addition to these official University prizes and scholarships it should be noted that there are available a number of scholarships and prizes from external sources for which University students can compete. Information about these scholarships and prizes appears from time to time on official noticeboards.

Please note that the conditions of the awards listed in this handbook were correct at the time of printing, but are to be reviewed in 1998 due to extensive course restructuring in 1997 and may be subject to change.

### **Faculty of Science Doctoral Research Scholarships**

A number of Doctoral Research Scholarships may be offered to permanent residents by the Faculty for full-time study towards a PhD. The awards which may be up to the value of \$15,000 per annum over three years are available for study in the following areas:

- Materials technology
- Image processing and analysis
- Regional and resource geology
- Science education
- Cell and molecular biology
- Biomedical science and engineering
- Environmental biology and toxicology
- Groundwater management
- Biomedical technology
- Forensic and analytical chemistry
- Coastal resource management

### **Dean's Merit List for Academic Excellence**

The Faculty wishes to formally recognise outstanding performance by its students through the awarding of prizes, medals and the grading of degrees. The Dean's Merit List



endeavours to formally acknowledge academic achievement throughout a student's course of study. From the end of 1993 and each year thereafter, the Faculty publishes a list of students who have been placed on the Dean's Merit List. Each student also receives a certificate to this effect. To be listed a student would usually need to undertake a normal load, achieve an average mark for the year of 85 or above and be recommended by the relevant Examination Review Committee in December each year.

#### **AC Hatrick Chemicals Prize**

This prize was established in 1990. It is awarded to the full-time student enrolled in the Applied Chemistry course who obtains the highest aggregate mark in Chemical Process Control. The prize has a cash value of \$250.

#### **Australasian Association of Clinical Biochemists Prize**

This prize was established in 1995 by the New South Wales Branch of the Australasian Association of Clinical Biochemists. It is offered annually to the graduating student from the Master of Science in Clinical Biochemistry course who has gained the highest weighted average mark in the subjects Clinical Biochemistry Advanced Aspects A, Clinical Biochemistry Advanced Aspects B, Case Studies in Clinical Biochemistry, and Clinical Laboratory Management. The prize consists of a suitably worded plaque, a cash award of \$200 and one year's membership of the Australasian Association of Clinical Biochemists.

#### **The Australian Acupuncture Association Prize**

This prize is awarded to the graduating student from the Bachelor of Health Science in Acupuncture course who obtains the highest weighted average mark for all subjects in the course. The prize is in the form of a suitably worded certificate, together with a book allowance to the value of \$250 plus one year's complimentary membership of the Australian Acupuncture Association Limited.

#### **The Australian Ceramic Society Prize in Ceramics**

This is a cash prize of \$100, intended for the purchase of books, and is awarded annually to the final-stage student in the Materials Science degree course who achieves the highest aggregate mark in the subjects Traditional Ceramics and Technical Ceramics in the year for which the award is made. The

prize, established in 1979 through the generosity of the NSW Branch of the Australian Ceramic Society, is intended as an encouragement to students studying in the field of ceramics.

#### **The Australian Ceramic Society Scholarship**

The Australian Ceramic Society Scholarship was established in 1986 and is awarded annually to the student enrolled in the Materials Science degree course who, when undertaking a research project in the area of ceramics, obtains the highest average mark in Stages 1, 2, 3 and 4. The cash value of the scholarship is \$400.

#### **Australian Institute of Medical Scientists' Prize in Clinical Bacteriology**

This prize was established in 1983 by the New South Wales Branch of the Australian Institute of Medical Laboratory Scientists. It is offered annually to students enrolled in the Biological and Biomedical Sciences courses and is awarded to the student who obtains the highest mark in the subject Clinical Bacteriology. The prize consists of a cash award of \$200, a suitably worded bronze medallion, and one year's membership of the Institute.

#### **Australian Institute of Medical Scientists' Prize in Haematology**

This prize was established in 1983 by the New South Wales Branch of the Australian Institute of Medical Laboratory Scientists. It is offered annually to students enrolled in the Biological and Biomedical Sciences courses and is awarded to the student who obtains the highest mark in the subject Haematology 2. The prize consists of a cash award of \$200, a suitably worded bronze medallion, and one year's membership of the Institute.

#### **Australian Institute of Physics Prize**

The NSW Branch of the Australian Institute of Physics has made available an annual award to a student in the fourth year of the Physics degree who obtains the best results in completing the final stage of the course. The prize is a cash award of \$200 plus one year's free membership of the Australian Institute of Physics.

### **Boehringer Mannheim Prize for Biomedical Sciences**

This prize was established in 1990. It is awarded annually to the student enrolled in the Biomedical Science degree course who achieves the highest average mark in Stage 3, obtaining at least a distinction average mark. The prize consists of a medal and a cash award of \$250.

### **Cathay Herbal Laboratories Prize**

This prize is awarded annually to the graduating student from the Bachelor of Health Science in Acupuncture course who obtains the highest aggregate mark in the final year clinical subjects. The prize will be in the form of a suitably worded certificate, together with Cathay Herbal Laboratories products such as textbooks, acupuncture supplies, herbal medicines and educational services, to the value of \$1,000.

### **Chemistry Department Prize**

This prize was established in 1986. It is awarded annually to the student enrolled in the Applied Chemistry degree course who, having completed Stage 2 of the course, obtains the best performance in the Stage 2 chemistry subjects Chemistry 2M or Chemistry 2 and Organic Chemistry 1. The prize is valued at \$100.

### **CHINAHERB Prize**

This prize is awarded to the graduating student from the Bachelor of Health Science in Acupuncture course who obtains the highest weighted average mark for TCM subjects in the year. The prize is in the form of a suitably worded certificate, together with a \$200 cash prize and a \$300 credit account with CHINAHERB.

### **Colin Field Prize**

This prize was established in 1989 by Emeritus Professor Colin Field, former Dean of the Faculty of Life Sciences and Head of the School of Biological and Biomedical Sciences. The prize is awarded annually to the Biomedical Science, Environmental Biology or Biotechnology student who obtains the highest overall average mark from all subjects undertaken in Stages 1 and 2, with at least a credit average for the biology subjects offered in those stages. The prize has a cash value of \$200.

### **CSL (Commonwealth Serum Laboratories) Prize**

This prize was established in 1990. It is awarded to the graduating student from the Biological and Biomedical Sciences degrees who attains the highest aggregate mark in the subject Transfusion Science, with a mark at distinction level or higher. The prize has a cash value of \$200.

### **Department of Land and Water Conservation Prize**

This prize was first established as the Department of Water Resources Prize in 1990. It is awarded annually to a student enrolled in the Biological and Biomedical Sciences courses who obtains the highest average mark in the subjects Aquatic Ecology, Terrestrial Ecosystems, and Mapping and Remote Systems, provided that the average mark is of distinction grade. The prize has a cash value of \$250.

### **DFC Thompson Memorial Prize**

This prize is awarded annually to the student who, upon completion of Stage 5 in the Chemistry degree course, obtains the highest weighted average mark for subjects in Stages 3, 4 and 5 of the course. The prize consists of a suitably worded certificate, together with a cash prize of \$1,000.

### **Dr David Sugerman Prize in Pathology**

This prize was established in 1982 by Dr David Sugerman. The prize is awarded annually to the student who obtains the highest aggregate in the subjects Anatomical Pathology, Immunology and Haematology, provided that the student reaching the highest aggregate has an average mark of not less than the standard of credit. The prize consists of a cash award of \$750 and a suitably worded plaque.

### **The Environmental Biology Prize**

This prize was established anonymously in 1984. The prize has a cash value of \$250 and is awarded to the student enrolled in the BSc Environmental Biology degree course who obtains the highest average mark in Stages 3 to 6 of the degree course.

### **Foseco Prize in Materials Science**

This prize was established in 1982 by Foseco Pty Ltd as an incentive to students engaged in studies in the field of Materials Science. The prize is offered annually to students enrolled in the Materials Science degree course and is

awarded to the student who achieves the highest aggregate mark in the subject Physical Properties of Materials. The prize consists of a cash award of \$200.

#### **Francis E Feledy Memorial Prize**

This award was established by the staff of the British Motor Corporation as a memorial to the late Francis E Feledy for his work as an architect and engineer with that company. The award was first made available in 1966 through the then Department of Technical Education. In 1974, the then Institute became the Trustee of the fund. At the discretion of the Trustee, the prize is awarded annually to an outstanding part-time student entering his or her final year in each of the Faculties of Engineering, Science, and Design, Architecture and Building. The prize is valued at \$600 for each award.

#### **Hatrick-Jotun Prize in Design and Materials Selection**

This prize (formerly the Hatrick Fiberfil Prize in Design and Materials Selection) was re-established in 1986. It is awarded to the student in the Materials Science degree course who achieves the best performance in the subject Design and Selection of Materials. The prize has a cash value of \$250.

#### **Hatrick Reichhold Prize in Polymer Technology**

This prize was established in 1984 by A C Hatrick Chemicals Pty Ltd as an incentive to students studying in the field of polymers and resin technology. The prize is awarded to the student who achieves the best performance in the subject Industrial Polymer Technology. The cash value of the prize is \$250.

#### **The Institute of Metals and Materials Australasia Prize**

This prize, established in 1983, is offered annually to students in the Materials Science degree course, and will be awarded to the student who achieves the highest mark in the subject Physical Metallurgy 1. The prize consists of a cash award of \$200 and one year's membership of the Institute of Metals and Materials Australasia.

#### **JEOL Prize for Electron Microscopy**

This prize was established in 1991. It is awarded to the student who achieves the highest mark in the subject Electron Microscopy Techniques. The prize has a cash value of \$250.

#### **KK & S Prize in Metallurgy**

This prize was established in 1982 by KK & S Instruments Pty Ltd as an incentive to students engaged in studies in the field of metallurgy. The prize is offered annually to students enrolled in the Materials Science degree course, and is awarded to the student who achieves the best performance in the subject Physical Metallurgy 3. The prize has a cash value of \$150.

#### **Leonard J Lawler Prize**

This prize is presented by the Australian Institute of Medical Scientists in dedication to the past services of Mr L J Lawler to the New South Wales Branch of the AIMS. Over a long period Mr Lawler has shown great interest in the education of clinical chemists. The prize has been awarded annually since 1976. It is awarded to the student enrolled in the Biomedical Science course who attains the best aggregate in the subjects Clinical Biochemistry 1 and Clinical Biochemistry 2. The prize consists of a cash award of \$200, a suitably worded bronze medallion and one year's membership of the Institute.

#### **Loctite Australia Prize in Adhesion Science**

This prize was established in 1983. It is awarded annually to the student enrolled in the Materials Science degree course who achieves the best performance in the subject Surface Properties of Materials. The prize has a cash value of \$150.

#### **Macquarie Pathology Services Prize in Biomedical Science**

This prize was established in 1984 by Macquarie Pathology Services Pty Ltd. The prize is awarded annually to the student who obtains the highest average mark in Stages 3 – 6 of the degree course leading to the award of BSc in Biomedical Science. The prize includes a cash award of \$500 and a medal.

#### **MY Ali Prize in Cytopathology (previously known as MY Ali Prize in Diagnostic Cytology)**

This prize was established in 1978 by Dr M Y Ali, former Associate Head of the School of Life Sciences at NSWIT, who was responsible for the introduction and initial development of studies in diagnostic cytology. It is awarded annually to the student enrolled in the Biomedical Science degree course who achieves the highest mark in the subject Cytopathology, provided that the mark is not

less than credit level. The prize consists of a cash award of \$200 and a suitably worded certificate.

### **National Safety Council of Australia Prize**

The National Safety Council of Australia Prize was established in 1986 and is awarded to the student enrolled in the Applied Chemistry degree course who obtains the highest aggregate mark in the subject Chemical Safety. The prize is in the form of a book token to the value of \$100.

### **The New South Wales Police Service Prize**

This prize was established in 1997 by the New South Wales Police Service Education and Training Command. It is awarded to the student enrolled in the Bachelor of Applied Science (Honours) in Applied Chemistry – Forensic Science who obtains the highest weighted average mark for the Forensic Examination of Physical Evidence subjects. The prize consists of a suitably worded certificate together with a cash award of \$500.

### **Pasminco Prize in Extractive Metallurgy**

This prize was established in 1990. It is awarded to the student enrolled in the Physical Sciences courses who obtains the highest aggregate mark in the subject Extractive Metallurgy. The prize has a cash value of \$250.

### **Pfizer Achievement Award**

This prize was established in 1997 by Pfizer Pty Ltd. It is awarded to the student enrolled in either the Applied Chemistry degree course or the Forensic Science degree course who achieves the highest mark in the subject Organic Chemistry 2, provided that the grade obtained is not lower than Distinction. The prize has a cash value of \$1,000.

### **Physics Staff Prize**

This prize was established in 1985. It is awarded each year to the student in the Applied Physics degree course who obtains the highest average mark in the first three stages of the course. The prize has a cash value of \$200.

### **Ratcliffe Prize**

Awarded for the best aggregate result of the Graduate Diploma in Occupational Health and Safety course.

### **R F G MacMillan Award**

This prize was established in 1991. It is awarded to a Materials Science degree student for participation and involvement in Materials Science activities beyond the normal academic requirements. The prize has a cash value of \$500.

### **Robert K Murphy Research Fund**

To perpetuate the name of Dr R K Murphy, who was for 25 years Lecturer-in-Charge of the Chemistry Department and subsequently Principal of Sydney Technical College, the Sydney Technical College Science Association sponsored a fund to be known as the Robert K Murphy Research Fund, to which a number of chemical industries also subscribed. The income from the fund has been applied to set up the following prizes and a scholarship:

#### **1. Robert K Murphy Research Prize**

This prize is awarded annually to the student in the Applied Chemistry degree course who submits the best original Chemistry project. The prize has a cash value of \$250.

#### **2. Robert K Murphy Prize**

This prize is awarded annually to the student in the Applied Chemistry degree course who entered the course on completion of Chemistry Certificate of the TAFE Commission and who achieves the best overall performance in the Applied Chemistry degree. The prize has a cash value of \$250.

#### **3. Robert K Murphy Research Scholarship**

This scholarship is awarded annually to the student in the Applied Chemistry degree course who satisfies the Trustees that such a scholarship is warranted to assist the student in research in investigation or advanced study. The prize has a cash value of \$250.

### **Schering Plough Prize**

This prize was established in 1990. It is awarded to the student enrolled in an Advanced Chemistry project in the Applied Chemistry course who presents the best project seminar (in terms of both technical merit and presentation). The prize has a cash value of \$250.

### **SICPA Australia Award**

This is a cash prize of \$40, intended for the purchase of books, and is to be awarded annually to the student in the Materials Science degree course who achieves the highest aggregate mark in the subject Polymers 1 in the year for which the award is made. The

prize, established in 1979 through the generosity of Collie Cooke Consolidated, is intended as an encouragement to students studying in the field of Organic Materials.

#### **St Joe Mineral Deposits Prize**

St Joe Australia Pty Ltd established this prize in 1984. The prize is awarded to the student who obtains the highest credit point average in the subject Mineral Deposits. The prize has a cash value of \$50.

#### **Stanton Coalstad Prize**

This prize may be awarded annually to a student enrolled in the Materials Science degree course who obtains the highest mark in the subject Materials Science 1 at his or her first attempt. The prize will be valued at \$500 and will comprise a cash award and a book voucher.

#### **Sydney Environmental and Soil Laboratory Prize in Urban Horticulture**

This prize is awarded to the graduating student from the Bachelor of Science (Urban Horticulture) course who obtains the highest weighted average mark in Stages 3 – 6 of the course, at Distinction level or above. The prize will be in the form of a suitably worded certificate, together with a cash prize of \$300.

#### **Western Mining Corporation Prize**

This prize was established in 1986. It is awarded annually to the student enrolled in the Applied Geology course who obtains the highest average mark of all students undertaking the Field Project in the year for which the award is made. The successful student will preferably demonstrate an interest in metalliferous exploration geology. The prize has a cash value of \$200.

#### **Western Mining Corporation Junior Studies Prize**

This is a cash prize of \$150 awarded annually to the student who has shown the most significant improvement in the quality of academic work at the completion of Stage 4 in the Materials Science degree course. The prize was awarded for the first time in 1979.

#### **Western Mining Corporation Senior Studies Prize**

This is a cash prize of \$150 awarded annually, subject to a suitable recipient being nominated by the Head of the Department of Materials Science, for distinguished performance in the final year (Stages 5 and 6) of the Materials Science degree course. The prize was awarded for the first time in 1979.

#### **Workcover Authority Prize**

Awarded for the highest aggregate mark in the first year of study in the Graduate Diploma in Occupational Health and Safety or Master of Occupational Health and Safety course.

#### **Yakult Student Award in Biotechnology**

This prize was established in 1996. It is awarded to the graduating student in the Bachelor of Science in Biotechnology course who obtains the highest weighted average mark for the subjects Microbiology 3 and the specialist biotechnology subjects Bioprocessing and Applied and Environmental Microbiology, provided that average mark is at credit level or higher. The prize is valued at \$250.

## LIST OF COURSES AND CODES

Course title	Code
<b>Undergraduate degrees</b>	
Bachelor of Applied Science in Chemistry <sup>1</sup>	NC01
Bachelor of Applied Science (Honours) in Chemistry <sup>1</sup>	NC02
Bachelor of Science in Applied Chemistry	NC05
Bachelor of Science (Honours) in Applied Chemistry	NC06
Bachelor of Applied Science in Geology <sup>1</sup>	NG01
Bachelor of Applied Science (Honours) in Geology	NG02
Bachelor of Science in Earth and Environmental Science	NG05
Bachelor of Science (Honours) in Geoscience	NG06
Bachelor of Science (Honours) in Environmental Science	NG07
Bachelor of Applied Science in Materials Science <sup>1</sup>	NM02
Bachelor of Applied Science (Honours) in Materials Science <sup>1</sup>	NM03
Bachelor of Science in Materials Science	NM05
Bachelor of Science (Honours) in Materials Science	NM06
Bachelor of Applied Science in Physics <sup>1</sup>	NP01
Bachelor of Applied Science (Honours) in Physics <sup>1</sup>	NP02
Bachelor of Applied Science in Physics/Bachelor of Engineering in Electrical Engineering <sup>1</sup>	NP03
Bachelor of Science in Applied Physics/Bachelor of Engineering in Electrical Engineering/ Diploma in Engineering Practice	NP04
Bachelor of Science in Applied Physics	NP05
Bachelor of Science (Honours) in Applied Physics	NP06
Bachelor of Health Science in Acupuncture	P005
Bachelor of Health Science in Acupuncture (Honours)	P006
Bachelor of Health Science in Acupuncture/Bachelor of Arts in International Studies	NH01
Bachelor of Health Science in Chinese Herbal Medicine	NH02
Bachelor of Health Science in Chinese Herbal Medicine (Honours)	NH03
Bachelor of Medical Science	NH04
Bachelor of Science (Honours) <sup>2</sup>	KB04
Bachelor of Science (Honours) in Applied Chemistry – Forensic Science	NC04
Bachelor of Science in Biomedical Science	KB02
Bachelor of Science in Biotechnology	KB06
Bachelor of Science in Environmental Biology	KB05
Bachelor of Science in Environmental and Urban Horticulture	KB03
Bachelor of Science in Science Education	N003
Bachelor of Science/Bachelor of Arts in International Studies	N004
Bachelor of Science/Bachelor of Laws	LL04
Bachelor of Medical Science/Bachelor of Laws	LL09
<b>Graduate Certificates</b>	
Coastal Resource Management <sup>3</sup>	KB69
Principles of Ecotoxicology <sup>4</sup>	KB77
Laboratory Methods in Ecotoxicology <sup>4</sup>	KB83
Field Methods in Ecotoxicology <sup>4</sup>	KB84
Management in Ecotoxicology <sup>4</sup>	KB85
Medical Microbiology	KB86
Molecular Microbiology	KB87
Diagnostic Bacteriology	KB88
Parasitology and Mycology	KB89
Clinical Biochemistry	KB79
Biochemical Analysis	KB81
Medical Biochemistry	KB82

## 34 FACULTY INFORMATION

Course title	Code
Environmental Engineering and Management	EC58
Occupational Health and Safety	P053
Occupational Health and Safety Management	P054
<b>Graduate Diplomas</b>	
Hydrogeology and Groundwater Management	N061
Occupational Health and Safety	P052
<b>Master's degrees (by coursework)</b>	
Master of Coastal Resource Management <sup>3</sup>	KB59
Master of Health Science in Traditional Chinese Medicine	NH61
Master of Occupational Health and Safety	P055
Master of Science in Clinical Biochemistry	KB55
Master of Science (Honours) in Clinical Biochemistry <sup>5</sup>	KB61
Master of Science in Ecotoxicology <sup>4</sup>	KB52
Master of Science (Honours) in Ecotoxicology <sup>5</sup>	KB62
Master of Science in Hydrogeology and Groundwater Management	N057
Master of Science in Medical Microbiology	KB57
Master of Science (Honours) in Medical Microbiology <sup>5</sup>	KB60
<b>Master's degrees (by thesis)</b>	
Master of Applied Science (Hydrogeology and Groundwater Management)	N056
Master of Science (Biological and Biomedical Science)	KB51
Master of Science (Physical Sciences)	N053
<b>Doctor of Philosophy</b>	
PhD (Biological and Biomedical Sciences)	KB56
PhD (Hydrogeology and Groundwater Management)	N055
PhD (Multidisciplinary Studies)	P095
PhD (Physical Sciences)	N054

<sup>1</sup> Only available to students who commenced their course before 1997.

<sup>2</sup> Offered to students who possess, or have fulfilled, all the requirements for a three-year Bachelor's degree in Biomedical Science, Biotechnology, Environmental Biology, Environmental and Urban Horticulture or Medical Science from UTS, or equivalent, with at least an average credit grade in the final two stages of the undergraduate program.

<sup>3</sup> Interdisciplinary course run by the Faculty of Science in collaboration with the Faculties of Engineering; Business; Law; and Design, Architecture and Building. Modified Graduate Certificate Programs in Coastal Resource Management will be offered subject to University approval.

<sup>4</sup> In collaboration with the NSW Environment Protection Authority.

<sup>5</sup> Subject to approval by Academic Board.

Most programs are available on a full-time and part-time basis or a combination of both these attendance patterns.

While the University of Technology, Sydney maintains traditional university standards of scholarly excellence in the granting of its awards, it is continually seeking to instruct students in new and innovative areas in keeping with the needs of our highly technological society.

## INTERNATIONAL STUDIES ELECTIVES

The Institute for International Studies in UTS offers electives in language studies and in the study of contemporary societies in parts of the non-English-speaking world. All subjects are taught over one semester and have a value of eight credit points.

### Language Studies

All students wishing to take language studies as a credited part of their degree are required to enrol through the Institute for International Studies, whether the language studies are undertaken in UTS or elsewhere. The Institute teaches some language programs at UTS, has made arrangements with other universities for some languages to be taught to UTS students, and can make special arrangements for individual students to attend specific language programs where academic needs demand. The individual student's level of language proficiency before entry to the UTS program decides their level of language study. There is a range of entry levels to the various programs available. Most are available at beginner's and post-HSC levels, and some at more advanced levels.

The Institute offers language programs in: Cantonese, Chinese, Croatian, French, German, Greek, Indonesian, Italian, Japanese, Korean, Malaysian, Polish, Russian, Spanish, Slovenian, Thai and Ukrainian. The Institute can arrange for the teaching of other language programs depending on availability and demand.

### Contemporary Society

The Institute also offers a series of subjects that provide an introduction to the contemporary societies, politics, economics and culture of the countries of East Asia and South-East Asia, Latin America and Europe that are the areas of specialisation of the Institute.

Introductory subjects on the contemporary societies of China, Japan, South-East Asia, Hong Kong and Taiwan, Latin America and Europe will be available. There are no prerequisites for any of the Contemporary Society subjects. All subjects are taught in English and are available, with the permission of their faculties, to all UTS students.

Further information is available from the Institute for International Studies, UTS, 9-11 Broadway, telephone (02) 9514 1574, fax (02) 9514 1578 and the *Institute for International Studies Handbook*.



# Undergraduate courses

## PASS DEGREE COURSES

### Admission requirements

Applicants are considered for admission in accordance with the Rules and By-law of UTS as set out in the *UTS Calendar*, and on the basis of meeting the general requirements in one of the following categories:

- the NSW Higher School Certificate
- an appropriate TAFE award – Diploma, Associate Diploma or completion of a Tertiary Preparation Course (TPC)
- equivalent qualifications
- mature age (see *UTS Calendar* for details)
- accumulated matriculation (see *UTS Calendar* for special circumstances).

### Assumed knowledge/course prerequisites

There are no mandatory prerequisite subjects from the Higher School Certificate; all science subjects taught in the first semester assume no HSC knowledge of the subject. However, it is assumed that all students entering the biological and medical sciences courses will have studied **at least** two-unit mathematics plus one two-unit science course. It is strongly recommended that they complete studies in two science subjects. Common combinations include chemistry/physics or chemistry/biology. For students entering the physical sciences courses, it is assumed that they have studied two-unit mathematics plus two-unit physics, or two-unit chemistry or three-/four-unit science. The minimum Tertiary Entrance Rank (TER) varies from year to year depending upon the number of applications for entry and the number of places available.

## Requirements for award of Bachelor's degree

A degree will be awarded to students satisfactorily completing the following requirements:

### I. Credit points<sup>1</sup>

A minimum of 144 credit points, accumulated by:

- full-time attendance in Bachelor's degree courses involving satisfactory completion of the prescribed core subjects and other approved subjects to the value of 48 credit points for each of three years;

or

- part-time attendance in Bachelor's degree courses involving satisfactory completion of the prescribed core subjects and other approved subjects to the value of 24 credit points for each of six years;

or

- any other approved combination of full-time and part-time attendance.

<sup>1</sup> Attendance patterns: the terms 'full-time' and 'part-time' refer to the number of credit points being undertaken and do not imply attendance at any particular time of day. The Faculty of Science normally schedules classes between 9.00 a.m. and 10.00 p.m., and students may be required to attend any scheduled class regardless of their attendance pattern. It is unavoidable that full-time students will be required to attend some evening classes and that part-time students will be required to attend some daytime classes.

Students who have failed subjects cannot be guaranteed a complete program or normal progression. However, in some courses a subject failed with a mark of 40 per cent or more may allow progression into subjects for which the failed subject is a prerequisite. All prescribed subjects must be successfully completed for award of a degree.

Students having difficulty devising a program should consult the Student Administrative Officer or an academic adviser. Where a student experiences legitimate difficulty enrolling in sufficient credit points to make up a full-time load, a minimum of 75 per cent of a normal full-time program is deemed adequate to maintain designation as a full-time student provided the whole degree is completed within 150 per cent of the normal progression period. Thus, a three-year full-time degree

should be completed in or under four-and-a-half years. Similarly, there is no minimum number of credit points for a part-time program for any one semester, but the whole degree should be completed within 150 per cent of the normal progression period i.e. a six-year part-time degree should be completed in or under nine years.

## 2. Professional/industrial experience

Students enrolled in science courses have the option to undertake industrial training or other relevant professional experience additional to the normal academic requirements of their course. In most cases this will involve spending up to 12 months working in a relevant industry. This experience will normally be gained prior to completing the academic requirements of the course and will earn the student extra academic credit which will be recognised by the award of a Diploma in Scientific Practice. Further details appear below.

## General structure of the Bachelor of Science and Bachelor of Medical Science courses

In 1997, the structures of all undergraduate courses except the Bachelor of Health Science courses were extensively revised with the aim of increasing the study options available to students. As a result, the general structure of these courses from 1998 will conform to a pattern comprising four components:

- i) a *'core discipline [major] strand'* (approximately 72 credit points) consisting of the prescribed subjects that define the course and form the basis for professional recognition;
- ii) a variable number of prescribed *'core support'* subjects (normally 24 – 36 credit points in stages 1 – 3) which underpin the core discipline strand though may not contribute directly to the requirements for professional recognition;
- iii) a *'second major'* component (normally 24 credit points) comprising a coherent set of non-prescribed subjects offered by the Faculty of Science, by another faculty of the University or by the Institute for International Studies;
- iv) *'free elective'* subjects (12 – 24 credit points), selected from anywhere in the University or cross-institutionally.

Details of some second majors offered by the Faculty of Science and other parts of the University are given at the end of the Undergraduate Courses section of this Handbook.

## Diploma in Scientific Practice

Students in the Bachelor of Science or Bachelor of Medical Science courses (including the combined courses with Law and International Studies) may elect to undertake an approved professional/industrial experience program concurrently with their academic studies. Successful completion of the program will entitle them to the award of a Diploma in Scientific Practice in addition to their Bachelor degree. The additional subjects that make up the diploma program will carry a total credit point load of 12 credit points and will be HECS-liable. The program is planned for introduction in 1999 and will be available to students who commenced their science course in 1997 or later. Students will normally enrol in the professional experience subjects after completing the first four stages of their academic program but prior to completing the final stage.

It is anticipated that the minimum requirement for the award of the diploma will be the completion of at least 1,200 hours of approved and supervised professional/industrial experience in a relevant field, over a period of not less than 30 weeks. Each student will enter into a learning contract to which the Faculty and the professional/industrial supervisor will also be party, and will be required to submit an assessable report upon completing the period of work experience.

Further details will be made available to current and prospective students during 1998.

It should be noted that the diploma program will replace the compulsory industrial training component which was a feature of the former Bachelor of Applied Science courses offered by the Faculty.

## HONOURS DEGREE COURSES

Honours programs provide basic training in research and introduce students to advanced areas of study in the relevant discipline. Graduates generally enter occupations for which an Honours degree is the minimum requirement, or continue with postgraduate research.

### Admission

From 1999 all Honours courses except the Bachelor of Science (Honours) in Applied Chemistry – Forensic Science and the Bachelor of Health Science (Honours) courses will be one-year full-time or equivalent part-time courses. They will be open to students who possess, or have fulfilled all the requirements for, a relevant Bachelor's degree from UTS, or equivalent qualification, with at least an average credit over the final third of the undergraduate program.

### Attendance patterns

Honours courses are offered as full-time programs over two semesters or part-time programs over four semesters. The major component is a research project which extends over the whole duration of the course and normally takes the form of an experimental or analytical investigation, undertaken either in the laboratory or the field. Candidates may also be required to undertake one or more critical reviews of the scientific literature in designated areas and to attend formal classes devoted to advanced coursework. The results of the project are presented in an oral seminar and in a written thesis, both of which are formally assessed.

### Application and selection

Prospective candidates should make an application to the Registrar by 31 October for entry to the Honours degree program in the first semester of the following year. There is provision for consideration of late applications. Applications for entry to Honours degree courses will be considered by a relevant Faculty selection committee. The Registrar will notify applicants of the results of their applications.

### Fees and Higher Education Contribution Scheme

Higher Education Contribution Scheme (HECS) fees will normally apply to all students enrolled in Honours courses. All enrolled students are also required to pay the compulsory University Union and Students' Association charges on enrolment.

### Commencement date

Students commencing their Honours course in Autumn semester are normally required to commence work on their Honours program on the first Monday in February. This applies even when formal enrolment is held after this date. Students should contact their supervisor for details.

### Award

Honours degrees may be awarded in the following grades: First Class, Second Class Division 1, Second Class Division 2, and Third Class.

They will be referred to as Bachelor of Science (Honours).

Abbreviation: BSc (Hons).

### Further information

Interested students should discuss the program and the possible research projects available with the relevant Head of Department or Honours Course Coordinator, or with individual members of academic staff.

### Transfer to Honours courses in the physical sciences in 1998

Students enrolled in courses in the physical sciences and who have completed the first four stages of their course at the commencement of 1998 may be permitted to transfer to the existing cognate Honours program under the same conditions as those applying in 1997. Students should consult with the relevant Head of Department or Honours Course Coordinator before lodging an application for Internal Course Transfer with the Registrar. This should be done well in advance of the commencement of the semester in which students intend to begin their Honours program.

## Bachelor of Science in Applied Chemistry

**New course code: NC05**

**Old course code: NC01 Bachelor of Applied Science in Chemistry (for pre-1997 students)**

This course gives students a firm foundation of study in the basic sciences, with in-depth development in the particular discipline of chemistry, emphasising its industrial applications. When coupled with concurrent work experience, for which an additional Diploma in Scientific Practice may be awarded, the course provides an excellent preparation for entry to professional work in the field of applied chemistry.

Students have the opportunity to tailor their studies to their individual interests. By taking an appropriate second major and selecting relevant electives, students can prepare themselves for employment in a variety of situations in industries concerned with plastics, paints, foods, metals and alloys, solvents or industrial chemicals.

Both the old course and the new course consist of six academic stages but the old course also includes a compulsory period of industrial training which extends the minimum completion time to four years. Although the new course can be completed by three years of full-time attendance if the professional/industrial experience component is not taken, students are strongly encouraged to undertake the industrial experience program. In this case a number of different patterns of attendance are possible: two years of full-time attendance followed by one year in industry and one year of full-time attendance; or two years of full-time attendance followed by two years of part-time attendance; or six years of part-time attendance. Other patterns of attendance may also be permitted.<sup>1</sup>

Full-time attendance involves approximately 24 hours each week at the University during the first year and 18 hours per week in the second and third years. This enables a full stage of the course to be completed in one semester.

Part-time attendance involves approximately 12 hours each week at the University in the first year and nine hours per week in the second and third years. This form of attendance allows students to complete a full stage in one year. It is expected that employers will release part-time students for at least one half-day per week for attendance at classes. Students commonly attend the University for one half-day and three evenings each week, or for two half-days and two evenings per week.

The award for successful completion of the new course is Bachelor of Science and for the old course Bachelor of Applied Science. The courses have been designed to meet the academic requirements for entry to corporate membership of the Royal Australian Chemical Institute.

The Honours program is designed to introduce students to more advanced coursework and to research work in chemistry. It allows selected students to continue on with postgraduate studies if desired and generally enhances their employment prospects.

The Department of Chemistry, Materials and Forensic Science strongly encourages students in the new course to undertake the professional/industrial experience option and an Industrial Training Committee within the Department of Chemistry, Materials and Forensic Science provides guidance in the matter of appropriate vocational training. The industrial component normally involves a minimum period of one year in full-time relevant employment. Each student is assigned to a member of staff who maintains regular contact during subsequent periods of study and employment.

<sup>1</sup> Holders of a TAFE Associate Diploma in Chemical Technology or equivalent qualification may be eligible for a number of subject exemptions and may therefore be able to complete the course in less than the standard time.

**Full-time program****New degree – NC05**

For students who commenced in 1997 or later.

**Stage 1****Autumn semester**

33190	Mathematical Modelling for Science	6cp
65101	Chemistry 1C	6cp
67101	Introduction to Materials	6cp
	<i>either</i>	
68101	Physics 1C <sup>1</sup>	6cp
	<i>or one of</i>	
66101	Earth Science 1	6cp
91311	Biology 1	6cp
91701	Medical Science 1	6cp

**Stage 2****Spring semester**

33290	Computing and Mathematics for Science	6cp
65201	Chemistry 2C	6cp
68201	Physics 2	6cp
	<i>or</i>	
68041	Physics 1A <sup>2</sup>	6cp
	<i>plus</i>	
	Approved science subject	6cp

**Stage 3****Autumn semester**

65202	Organic Chemistry 1	6cp
65306	Analytical Chemistry 1	6cp
65307	Physical Chemistry 1	6cp
	Elective/second major	6cp

**Stage 4****Spring semester**

65409	Analytical Chemistry 2	6cp
65411	Inorganic Chemistry 1	6cp
65410	Chemical Safety and Legislation	6cp
	Elective/second major	6cp

**Stage 5****Autumn semester**

65508	Organic Chemistry 2	6cp
65509	Inorganic Chemistry 2	6cp
	Electives/second major	12cp

**Stage 6****Spring semester**

65606	Analytical Chemistry 3	6cp
65607	Physical Chemistry 2	6cp
	Electives/second major	12cp

**Part-time program****New degree – NC05**

For students who commenced in 1997 or later.

**Stage 1****Autumn semester**

65101	Chemistry 1C	6cp
	<i>either</i>	
68101	Physics 1C <sup>1</sup>	6cp
	<i>or one of</i>	
66101	Earth Science 1	6cp
91311	Biology 1	6cp
91701	Medical Science 1	6cp

**Spring semester**

33190	Mathematical Modelling for Science	6cp
65201	Chemistry 2C	6cp

**Stage 2****Autumn semester**

33290	Computing and Mathematics for Science	6cp
67101	Introduction to Materials	6cp

**Spring semester**

65410	Chemical Safety and Legislation	6cp
68201	Physics 2	6cp
	<i>or</i>	
68041	Physics 1A <sup>2</sup>	6cp

**Stage 3****Autumn semester**

65202	Organic Chemistry 1	6cp
65306	Analytical Chemistry 1	6cp

**Spring semester**

65411	Inorganic Chemistry 1	6cp
	Elective/second major	6cp

**Stage 4****Autumn semester**

65307	Physical Chemistry 1	6cp
	Elective/second major	6cp

**Spring semester**

65409	Analytical Chemistry 2	6cp
	Elective/second major	6cp

**Stage 5****Autumn semester**

65508	Organic Chemistry 2	6cp
	Elective/second major	6cp

**Spring semester**

65606	Analytical Chemistry 3	6cp
	Elective/second major	6cp

**Stage 6**
**Autumn semester**

65509	Inorganic Chemistry 2	6cp
	Elective/second major	6cp

**Spring semester**

65607	Physical Chemistry 2	6cp
	Elective/second major	6cp

<sup>1</sup> Strongly recommended.

<sup>2</sup> Not available to students who have completed 68101 Physics 1C.

## Sandwich program

### Old Pass degree – NC01

For students who commenced before 1997.

**Stages 1 – 2**

See 1997 Handbook.

**Stage 3**
**Autumn semester**

60301	Treatment of Scientific Data	3cp
65301	Spectroscopy and Structure	7cp
65302	Inorganic Chemistry	7cp
65504	Chemical Safety	4cp
51357	Technical Communication	4cp

**Stage 4**
**Spring semester**

65401	Analytical Chemistry 1	8cp
65402	Organic Chemistry 2	8cp
65403	Electrochemistry	4cp
65404	Chemical Thermodynamics	4cp

**Autumn semester**

65996	Industrial Training 1 <sup>1</sup>
-------	------------------------------------

**Spring semester**

65997	Industrial Training 2 <sup>1</sup>
-------	------------------------------------

**Stage 5**
**Autumn semester**

33173	Science Mathematics 3	3cp
65501	Analytical Chemistry 2	8cp
65602	Reaction Kinetics	4cp
	Chemistry Elective(s) <sup>2</sup>	8cp

**Stage 6**
**Spring semester**

	Chemistry Elective(s) <sup>2</sup>	16cp
	Elective	8cp

<sup>1</sup> Industrial experience is a compulsory component of the old course. The minimum period of relevant employment required is the equivalent of one year's full-time employment. The Industrial Training Committee of the Chemistry Department provides guidance on this occupational requirement. The industrial training component in the sandwich program must be undertaken after the completion of the third or fourth semester of academic work. It must be undertaken before the last semester of academic work. The corresponding subject in the old Honours degree program is 65995 Industrial Training (Honours).

<sup>2</sup> Chemistry electives offered in 1998 (subject to satisfactory enrolments):

65601	Environmental Chemistry	8cp
65702	Applied Organic Chemistry 2	8cp
65502	Chemical Process Control	8cp
65603	Surface Chemistry	4cp
65703	Metallurgical Chemistry	8cp
65704	Coordination and Organometallic Chemistry	8cp
65705	Corrosion Science	8cp

## Part-time program

### Old Pass degree – NC01

Students who commenced before 1997 and have progressed beyond Stage 2 will be allowed to follow the old course to the extent that the relevant subjects, as detailed in the 1997 *Faculty of Science Handbook*, are available. Where subjects have been discontinued alternative programs of study should be arranged in consultation with academic advisers from the Department of Chemistry, Materials and Forensic Science.

## Bachelor of Science (Honours) in Applied Chemistry

**New course code: NC06**

**Old course code: NC02 Bachelor of Applied Science (Honours) in Chemistry (for pre-1997 students)**

The new Honours degree in Applied Chemistry is a one year full-time course, or equivalent part-time, which is taken after completing the Bachelor of Science in Applied Chemistry or an equivalent course with an average grade of at least credit over the final third of the course. The Honours degree offers basic training in research and introduces students to advanced areas of study in chemistry. The major component is a supervised individual research project which extends over the full duration of the course and normally takes the form of an experimental or analytical investigation undertaken in the laboratory.

Further details are provided in the general introduction to the Undergraduate Courses section of this handbook.

The old Bachelor of Applied Science (Honours) degree in Chemistry, which is expected to be discontinued in 1999, was a four-year full-time program, the first two years of which were identical to the old Pass degree course. All students were initially admitted to the Pass degree and to gain entry to the Honours program students had to achieve a Weighted Average Mark (WAM) of at least 65 for subjects in Stages 3 and 4.

Students wishing to undertake Honours in 1998 should contact the Head of the Department of Chemistry, Materials and Forensic Science for advice on the pattern of Honours most suitable for them, and consult the Chemistry noticeboards for details of available projects and supervisors.

## Full-time program

### New Honours degree – NC06

For students who commenced in 1997 or later.

#### Stage 1

65854	Honours (Chemistry) (2 sem)	24cp
-------	-----------------------------	------

#### Stage 2

65854	Honours (Chemistry) (2 sem)	24cp
-------	-----------------------------	------

## Sandwich program

### Old Honours degree

#### Years 1 and 2

As for stages 1 – 4 of the old Pass degree.

#### Year 3

##### Autumn semester

65602	Reaction Kinetics	4cp
65995	Industrial Training (Honours) Honours Elective <sup>1</sup>	8cp

##### Spring semester

33173	Science Mathematics 3	3cp
65551	Analytical Chemistry 2 (Advanced)	8cp
65995	Industrial Training (Honours)	

#### Year 4

##### Autumn semester

65851	Project 1 Honours Elective <sup>1</sup> Honours Elective <sup>1</sup>	8cp 8cp 8cp
-------	---	-------------------

##### Spring semester

65852	Project 2	16cp
65853	Honours Seminar	8cp

## Part-time programs

### New and Old Honours degrees – NC06 and NC02

Please contact the Department of Chemistry, Materials and Forensic Science for advice.

<sup>1</sup> Chemistry electives to be offered in 1998 (subject to satisfactory enrolments):

65702	Applied Organic Chemistry 2	8cp
65502	Chemical Process Control	8cp
65603	Surface Chemistry	4cp

Honours electives to be offered in 1998 (subject to satisfactory enrolments):

65651	Environmental Chemistry (Advanced)	8cp
65752	Applied Organic Chemistry 2 (Advanced)	8cp
65753	Metallurgical Chemistry (Advanced)	8cp
65754	Coordination and Organometallic Chemistry (Advanced)	8cp

# Bachelor of Science (Honours) in Applied Chemistry – Forensic Science

## Course code: NC04

This course provides a program of instruction which, together with a research project, will prepare students for entry to professional work in the field of applied chemistry or as a specialist in the forensic science area. The course includes a firm foundation of studies in the basic sciences, with in-depth development of the discipline of chemistry, emphasising its forensic applications.

## Length

The Bachelor of Science (Honours) in Applied Chemistry – Forensic Science will comprise four years of full-time coursework including one semester of research work.

## Attendance pattern

The course will be offered on a four-year full-time basis.

## Course structure

The first two years of the program are similar, though not identical to the Bachelor of Science in Applied Chemistry course. The final two years are strongly focused on forensic studies.

If the required standard for Honours is not achieved at the end of Stage 4, students' enrolment in the course will be discontinued and they will be offered the option of full-credit transfer to the Bachelor of Science in Applied Chemistry.

## Full-time program

Each stage corresponds to one semester of full-time attendance.

### Stage 1

#### Autumn semester

33190	Mathematical Modelling for Science	6cp
65101	Chemistry 1C	6cp
68101	Physics 1C	6cp
	<i>either</i>	
91311	Biology 1	6cp
	<i>or</i>	
91701	Medical Science 1	6cp

### Stage 2

#### Spring semester

33290	Computing and Mathematics for Science	6cp
65201	Chemistry 2C	6cp
65241	Principles of Forensic Science <i>one of</i>	6cp
67101	Introduction to Materials	6cp
68201	Physics 2	6cp
91702	Medical Science 2	6cp

### Stage 3

#### Autumn semester

65202	Organic Chemistry 1	6cp
65306	Analytical Chemistry 1	6cp
65341	Forensic Imaging	6cp
65307	Physical Chemistry 1	6cp

### Stage 4

#### Spring semester

65409	Analytical Chemistry 2	6cp
65411	Inorganic Chemistry 1	6cp
65410	Chemical Safety and Legislation	6cp
65541	Physical Evidence 1	6cp

### Stage 5

#### Autumn semester

65508	Organic Chemistry 2	6cp
65509	Inorganic Chemistry 2	6cp
65542	Forensic Toxicology 1	6cp
91141	Biological Evidence	6cp

### Stage 6

#### Spring semester

65606	Analytical Chemistry 3	6cp
65607	Physical Chemistry 2	6cp
65642	Forensic Toxicology 2	6cp
65641	Physical Evidence 2	6cp

### Stage 7

#### Autumn semester

65741	Chemistry and Pharmacology of Illicit Drugs	6cp
65742	Fire and Explosion Investigation	6cp
65743	Complex Forensic Cases (Chemistry)	6cp
79991	Complex Forensic Cases (Law)	6cp

### Stage 8

#### Spring semester

65856	Forensic Research Project	24cp
-------	---------------------------	------



## Bachelor of Applied Science in Geology

**Old course code: NG01**

**This has been replaced by the new course NG05 Bachelor of Science in Earth and Environmental Science.**

This course is available only to students who commenced before 1997. Students who commenced in 1997 will transfer to the new course Bachelor of Science in Earth and Environmental Science. Details of the new course are given immediately after this course.

The course is designed for students seeking careers as professional geologists. The basic award for successful completion of the course is Bachelor of Applied Science. At the end of Stage 4 of the course, more successful students may transfer to the Honours degree program.

The Pass course consists of six stages of formal study and at least one year of full-time (or its equivalent) relevant industrial experience. The formal study includes basic study of chemistry, physics, mathematics and geology, followed by general training in lithology and geological mapping, computer science, the treatment of scientific data, geodynamics and sedimentary, igneous and metamorphic geology. In the middle and later stages of the course, structural geology, exploration geophysics, remote sensing and tectonics are studied in association with exploration, resource, engineering and environmental geology, mining law, and financial aspects of the mineral industry. In these stages the student also studies a range of subjects in preparation for field and laboratory work in metalliferous and non-metalliferous exploration, and the geology of fossil fuels.

Industrial training is an essential part of the degree program, and is normally completed in two six-month periods, one after completion of Stage 4 and one on completion of Stage 6. The Department of Environmental Sciences maintains close liaison with potential employers and assists students to obtain appropriate positions. The student may make his or her own arrangements, but the Head of Department must be satisfied as to the suitability of the employment.

The common course patterns are four years of full-time enrolment, including two six-month periods of industrial training; or six years of part-time attendance,<sup>1</sup> while concurrently employed full-time in a relevant geological

field; or alternating periods of full-time study with similar periods of full-time relevant employment.

Full-time attendance involves 24 hours each week at the University; this enables a full stage of the course to be completed in one semester.

Part-time attendance involves about 12 hours each week at the University; with this form of attendance the equivalent of a full stage may be completed in one year. It is normal practice for employers to release part-time students for at least one half-day per week for attendance at classes. Students commonly attend the University for one half-day and three evenings each week, or for two half-days and two evenings each week.

<sup>1</sup> Industrial training can be achieved by concurrent suitable employment. The matter should be discussed with the Head, Department of Applied Geology.

### Sandwich program

#### Old pass degree – NG01

In these programs, each stage corresponds to one semester spent in full-time attendance at the University.

#### Stages 1 – 2

See 1997 *Faculty of Science Handbook*.

#### Stage 3

##### Autumn semester

31871	Computing for Science	3cp
60301	Treatment of Scientific Data	3cp
66301	Mineralogy and Petrology (2 sem)	4cp
66302	Sedimentary Geology	6cp
66303	Geochemistry	3cp
66402	Structural Geology	7cp

#### Stage 4

##### Spring semester

66301	Mineralogy and Petrology (2 sem)	4cp
66401	Technical Communication	3cp
66403	Economic Geology	4cp
66405	Basin Analysis	4cp
66406	Exploration Geophysics	4cp
66603	Remote Sensing	3cp

##### Autumn semester

66996	Industrial Training 1	
-------	-----------------------	--

#### Stage 5<sup>1</sup>

##### Spring semester

66404	Resource Management	3cp
66501	Engineering and Environmental Geology	5cp

66502	Advanced Petrology	4cp
66503	Fossil Fuels	4cp
66504	Exploration Geochemistry	2cp
66507	Project Seminar	3cp
66505	Advanced Structural Geology	4cp
66506	Advanced Geological Mapping	3cp

**Stage 6<sup>1</sup>**

**Autumn semester**

66601	Exploration and Mining Geology	4cp
66604	Field Project	9cp
66602	Tectonics	3cp
	<i>one of</i>	
66605	Advanced Fossil Fuels	4cp
66606	Mineral Deposits	4cp
66607	Advanced Engineering Geology	4cp

**Spring semester**

66997	Industrial Training 2	
-------	-----------------------	--

**Part-time program**

**Old pass degree – NG01**

**Stages 1 – 2**

See 1997 Faculty of Science Handbook.

**Stage 3**

**Autumn semester**

31871	Computing for Science	3cp
60301	Treatment of Scientific Data	3cp
66303	Geochemistry	3cp

**Spring semester**

66301	Mineralogy and Petrology	8cp
66302	Sedimentary Geology	6cp

**Industrial requirements**

66998	Industrial Training P/T	
-------	-------------------------	--

**Stage 4**

**Autumn semester**

66402	Structural Geology	7cp
66405	Basin Analysis	4cp
66406	Exploration Geophysics	4cp

**Spring semester**

66401	Technical Communication	3cp
66403	Economic Geology	4cp
66603	Remote Sensing	3cp

**Industrial requirements**

66998	Industrial Training P/T	
-------	-------------------------	--

**Stage 5<sup>1</sup>**

**Autumn semester**

66503	Fossil Fuels	4cp
66502	Advanced Petrology	4cp
66505	Advanced Structural Geology	4cp

**Spring semester**

66501	Engineering and Environmental Geology	5cp
66504	Exploration Geochemistry	2cp
66507	Project Seminar	3cp
66506	Advanced Geological Mapping	3cp

**Industrial requirements**

66998	Industrial Training P/T	
-------	-------------------------	--

**Stage 6<sup>1</sup>**

**Autumn semester**

66601	Exploration and Mining Geology	4cp
66604	Resource Management	3cp
	<i>one of</i>	
66605	Advanced Fossil Fuels	4cp
66606	Mineral Deposits	4cp
66607	Advanced Engineering Geology	4cp

**Spring semester**

66604	Field Project	9cp
66602	Tectonics	3cp

**Industrial requirements**

66998	Industrial Training P/T	
-------	-------------------------	--

<sup>1</sup> With permission of the Head of Department, other subjects may be substituted for particular subjects in Stage 5 or Stage 6, where this is appropriate.

## Bachelor of Science in Earth and Environmental Science

**New course code: NG05**

**Old course code: NG01 Bachelor of Applied Science in Geology**

This is a new course starting in 1998 which replaces the Bachelor of Applied Science in Geology. Students who enrolled in the first year of the Applied Geology degree course in 1997 will transfer to the new course.

The course is designed for students seeking careers as professional geoscientists or environmental scientists. The basic award for successful completion of the new course is Bachelor of Science.

The course consists of six stages of formal academic study and students also have the opportunity to undertake a professional/industrial experience program leading to the additional award of Diploma in Scientific Practice. The course begins with a study of basic chemistry, physics, biology, mathematics, computing, statistical design and analysis, and earth science, followed by a general training in field techniques, igneous, metamorphic and sedimentary origin, structural and resource geology. Exploration geophysics, remote sensing and tectonics are studied during the later part of the program in association with exploration, resource, engineering and environmental geology, quaternary geology and Earth dynamics. In addition, specialised earth sciences are available through the Sydney Universities Consortium of Geology and Geophysics (SUCOGG).

Concurrently with these studies in earth science, students undertake a second major in environmental studies which comprises a sequence of subjects including ecological sampling and experimentation, Australian biota and environmental management. These complementary studies are aimed at ensuring that the course produces graduates in earth science who also have a sound knowledge and awareness of environmental issues and practices to assist them in their professional careers. Students who already hold approved credentials in environmental science may be permitted to undertake a second major in another field of study.

Although the course may be completed by three years of full-time attendance if the

professional/industrial component is not taken, all students are strongly encouraged to undertake the industrial experience program. Hence, the common course patterns are four years of full-time enrolment, including one year of industrial experience; or six years of part-time attendance while concurrently employed full-time in a relevant geological field; or alternating periods of full-time study with similar periods of full-time relevant employment.

Full-time attendance involves approximately 24 hours each week at the University; this enables a full stage of the course to be completed in one semester.

Part-time attendance involves about 12 hours each week at the University; with this form of attendance the equivalent of a full stage may be completed in one year. It is expected that employers will release part-time students for at least one half-day per week for attendance at classes. Students commonly attend the University for one half-day and three evenings each week, or for two half-days and two evenings each week.

### Full-time program

#### New Pass Degree – NG05

##### Stage 1

##### Autumn semester

33101	Mathematics 1 (LS)	3cp
33106	Statistical Design and Analysis (2 sem)	3cp
66101	Earth Science 1	6cp
65012	Chemistry 1A	6cp
91311	Biology 1	6cp

##### Stage 2

##### Spring semester

33106	Statistical Design and Analysis (2 sem)	3cp
66204	Field Studies 1	6cp
65022	Chemistry 2A	6cp
91312	Biology 2	6cp
	<i>either</i>	
91395	Biocomputing	3cp
	<i>or</i>	
31871	Computing for Science	3cp

##### Stage 3

##### Autumn semester

66304	Earth Materials	6cp
66305	Fold Belts and Cratons	6cp
68041	Physics 1A	6cp
91303	Experimental Design in Ecology	3cp
91329	Ecological Sampling	3cp

**Stage 4**

**Spring semester**

66407	Mapping and Remote Sensing	6cp
66408	Earth Resources	6cp
66409	Surficial Processes and Products	6cp
91309	Australian Biota	6cp

**Stage 5**

**Autumn semester**

66508	Crustal and Mantle Processes	8cp
66509	Tectonics and Surface Dynamics	4cp
66510	Geophysics	4cp
	Electives	8cp

**Stage 6**

**Spring semester**

66609	Environmental and Quaternary Geology	8cp
66610	Engineering Geology	4cp
66034	Groundwater Geology	4cp
91327	Environmental Management Procedures	4cp
	Elective	4cp

**Part-time program**

**New Degree – NG05**

**Stage 1**

**Autumn semester**

65012	Chemistry 1A	6cp
66101	Earth Science 1	6cp

**Spring semester**

65022	Chemistry 2A	6cp
66204	Field Studies 1	6cp

**Stage 2**

**Autumn semester**

33101	Mathematics 1 (LS)	3cp
33106	Statistical Design and Analysis (2 sem)	3cp
91311	Biology 1	6cp

**Spring semester**

33106	Statistical Design and Analysis (2 sem)	3cp
91312	Biology 2	6cp
91395	Biocomputing	3cp
	<i>or</i>	
31871	Computing for Science	3cp

**Stage 3**

**Autumn semester**

66304	Earth Materials	6cp
68041	Physics 1A	6cp

**Spring semester**

66408	Earth Resources	6cp
91309	Australian Biota	6cp

**Stage 4**

**Autumn semester**

66305	Fold Belts and Cratons	6cp
91303	Experimental Design in Ecology	3cp
91329	Ecological Sampling	3cp

**Spring semester**

66407	Mapping and Remote Sensing	6cp
66409	Surficial Processes and Products	6cp

**Stage 5**

**Autumn semester**

66508	Crustal and Mantle Processes	8cp
66510	Geophysics	4cp

**Spring semester**

66609	Environmental and Quaternary Geology	8cp
	Elective	4cp

**Stage 6**

**Autumn semester**

66509	Tectonics and Surface Dynamics	4cp
	Elective	8cp

**Spring semester**

66610	Engineering Geology	4cp
66034	Groundwater Geology	4cp
91346	Environmental Management Procedures	4cp

## Bachelor of Science (Honours) in Geoscience

*New course code: NG06*

## Bachelor of Science (Honours) in Environmental Science

*New course code: NG07*

### *Old course code: NG02 Bachelor of Applied Science (Honours) in Geology*

These courses are for students who commenced in 1997 or later.

Both are one year full-time courses, or equivalent part-time, which are taken after completing the Bachelor of Science in Earth and Environmental Science or an equivalent course with an average grade of at least credit over the final third of the course. The Honours degrees offer basic training in research and introduce students to advanced areas of study in either geoscience or environmental science. The major component is a supervised individual research project which extends over the full duration of the course and normally takes the form of an experimental or analytical investigation undertaken in the laboratory or the field.

Entry requirements and further details are provided in the general introduction to the Undergraduate Courses section of this handbook.

The old Bachelor of Applied Science (Honours) degree in Geology, which is expected to be discontinued in 1999, was a four-year full-time program, the first two years of which were identical to the old Pass degree course. All students were initially admitted to the Pass degree and to gain entry to the Honours program students had to achieve a Weighted Average Mark (WAM) of at least 65 for subjects in Stages 3 and 4.

Students wishing to undertake Honours in 1998 should contact the Head of Department for advice concerning projects available and the pattern of Honours most suitable for them, and consult the Geology noticeboards for details of available projects and supervisors.

## Full-time program Bachelor of Science (Honours) in Geoscience

**New Honours degree – NG06**

### Stage 1

66854	Honours (Geoscience) (2 sem)	24cp
-------	------------------------------	------

### Stage 2

66854	Honours (Geoscience) (2 sem)	24cp
-------	------------------------------	------

## Full-time program – Bachelor of Science (Honours) in Environmental Science

**New Honours degree – NG07**

### Stage 1

66855	Honours (Environmental Science) (2 sem)	24cp
-------	--	------

### Stage 2

66855	Honours (Environmental Science) (2 sem)	24cp
-------	--	------

## Sandwich program

**Old Honours degree – NG02**

This program is available only to students who commenced the Bachelor of Applied Science in Geology (course code NG01) before 1997.

### Years 1 – 2

As for stages 1 – 4 of the old Pass degree (see 1997 *Faculty of Science Handbook*).

### Stage 5

#### Autumn semester

66995	Industrial Training (Hons)	
-------	----------------------------	--

#### Spring semester

66404	Resource Management	3cp
66501	Engineering and Environmental Geology	5cp
66504	Exploration Geochemistry	2cp
66506	Advanced Geological Mapping	3cp
66551	Advanced Structural Geology (Honours)	5cp
66552	Advanced Petrology (Honours)	5cp
66553	Fossil Fuels (Honours)	5cp

### Stage 6

#### Autumn semester

66601	Exploration and Mining Geology	4cp
66602	Tectonics	3cp
66858	Project (Honours) (2 sem)	8cp

	<i>two of</i>	
66651	Convergent Margin Tectonics (Honours)	3cp
66655	Structural Geology of Ore Deposits (Honours)	3cp
66653	Applied Clastic Basin Analysis (Honours)	3cp
	External SUCOGG <sup>1</sup> Elective	

### Stage 7

#### Spring semester

66858	Project (Honours) (2 sem) <i>one of</i>	20cp
66654	Research Developments in Geoscience External SUCOGG <sup>1</sup> elective	3cp

<sup>1</sup> SUCOGG: Sydney Universities Consortium of Geology and Geophysics.

Note: Where appropriate, and with the permission of the Head of Department, other subjects may be substituted for particular subjects in Stages 5 to 7.

## Bachelor of Science in Materials Science

### New course code: NM05

#### Old course code: NM02 Bachelor of Applied Science in Materials Science (for pre-1997 students)

With the advancement of technology comes an increasing demand for new, more specialised and more reliable materials. Modern engineering and scientific enterprises continue to involve larger and more complex structures or devices. Factors such as the operational behaviour, relative costs and the aesthetic appeal of different materials become more and more stringently specified. It is from this background that Materials Science has emerged as a separate field of study out of the traditional disciplines of physics, chemistry, metallurgy and engineering.

Materials Science deals with the scientific principles governing the engineering properties of materials and the application of these properties in modern technology. Metals, ceramics and organic materials are treated in an integrated manner to establish the criteria for materials selection in relation to service conditions, materials compatibility and material durability.

There are two degree programs available for students who commenced in 1997 or later, the Bachelor of Science in Materials Science and the Bachelor of Science (Honours) in Materials

Science. Students who began the Bachelor of Applied Science in Materials Science course prior to 1997 will normally be expected to remain in that course but may apply to transfer to the new courses. Graduates from these degrees will be well equipped to work in materials science-related industry. Honours degree graduates will, however, be better prepared to undertake postgraduate research.

The new Pass degree course consists of six stages of formal academic study and students also have the opportunity to undertake a professional/industrial experience program leading to the additional award of Diploma in Scientific Practice. Although the course may be completed by three years of full-time attendance if the professional/industrial experience component is not taken, all students are strongly encouraged to undertake the industrial experience program. Hence the common course patterns are four years of full-time enrolment, including one year of industrial experience; or six years of part-time attendance while concurrently employed in a relevant industry; or alternating periods of full-time study with similar periods of full-time relevant employment.

Full-time attendance involves approximately 24 hours each week at the University; this enables a full stage of the course to be completed in one semester.

Part-time attendance involves about 12 hours each week at the University; with this form of attendance the equivalent of a full stage may be completed in one year. It is expected that employers will release part-time students for at least one half-day per week for attendance at classes. Students commonly attend the University for one half-day and three evenings each week, or for two half-days and two evenings each week.

### Full-time program

#### New degree – NM05

For students who commenced in 1997 or later.

#### Stage 1

##### Autumn semester

33190	Mathematical Modelling for Science	6cp
65101	Chemistry 1C	6cp
67101	Introduction to Materials	6cp
68101	Physics 1C	6cp

## 50 UNDERGRADUATE COURSES

### Stage 2

---

#### Spring semester

33290	Computing and Mathematics for Science	6cp
65201	Chemistry 2C	6cp
67303	Mechanical Properties of Materials	6cp
68201	Physics 2	6cp

### Stage 3

---

#### Autumn semester

67304	Physical Metallurgy	6cp
67305	Polymer Science	6cp
67306	Industrial Ceramics Elective/second major	6cp

### Stage 4

---

#### Spring semester

67408	Industrial Metallurgy	6cp
67409	Polymer Technology	6cp
67506	Technical Ceramics Elective/second major	6cp

### Stage 5

---

#### Autumn semester

65062	Extractive Metallurgy	6cp
67407	Physical Properties of Materials Electives/second major	6cp 12cp

### Stage 6

---

#### Spring semester

67608	Composites	6cp
67606	Corrosion and Degradation of Materials Electives/second major	6cp 12cp

## Part-time program

### New degree – NM05

For students who commenced in 1997 or later.

### Stage 1

---

#### Autumn semester

65101	Chemistry 1C	6cp
68101	Physics 1C	6cp

#### Spring semester

33190	Mathematical Modelling for Science	6cp
65201	Chemistry 2C	6cp

### Stage 2

---

#### Autumn semester

33290	Computing and Mathematics for Science	6cp
67101	Introduction to Materials	6cp

### Spring semester

67303	Mechanical Properties of Materials	6cp
68201	Physics 2	6cp

### Stage 3

---

#### Autumn semester

67304	Physical Metallurgy	6cp
67305	Polymer Science	6cp

#### Spring semester

67408	Industrial Metallurgy	6cp
67409	Polymer Technology	6cp

### Stage 4

---

#### Autumn semester

67306	Industrial Ceramics Elective/second major	6cp 6cp
-------	---	------------

#### Spring semester

67506	Technical Ceramics Elective/second major	6cp 6cp
-------	--	------------

### Stage 5

---

#### Autumn semester

67407	Physical Properties of Materials Elective/second major	6cp 6cp
-------	--	------------

#### Spring semester

67608	Composites Elective/second major	6cp 6cp
-------	----------------------------------	------------

### Stage 6

---

#### Autumn semester

65062	Extractive Metallurgy Elective/second major	6cp 6cp
-------	---	------------

#### Spring semester

67606	Corrosion and Degradation of Materials Elective/second major	6cp 6cp
-------	--	------------

## Sandwich program

### Old Pass degree – NM02

For students who commenced before 1997. Students who are entering Stages 5 and 6 in 1998 should see Dr Abhi Ray, telephone 9514 1788, fax 9514 1628, email [Abhia.Ray@uts.edu.au](mailto:Abhia.Ray@uts.edu.au) for the revised program of study in 1998.

### Stages 1 – 2

---

See 1997 *Faculty of Science Handbook*.

### Stage 3

---

#### Autumn semester

67304	Physical Metallurgy	6cp
67306	Industrial Ceramics	6cp

67305	Polymer Science	6cp
65031	Thermodynamics	3cp
33173	Science Mathematics 3	3cp

**Stage 4****Spring semester**

67407	Physical Properties of Materials	6cp
67408	Industrial Metallurgy	6cp
31871	Computing for Science	3cp
67409	Polymer Technology	6cp
67410	Instrumentation for Materials Scientists	3cp

**Autumn semester**

67996	Industrial Training 1	
-------	-----------------------	--

**Spring semester**

67997	Industrial Training 2	
-------	-----------------------	--

**Stage 5****Autumn semester**

67506	Technical Ceramics	6cp
67602	Surface Properties of Materials	4cp
68071	Applied Physics (Materials)	4cp
67507	Composites	4cp
65062	Extractive Metallurgy	6cp

**Stage 6****Spring semester**

67606	Corrosion and Degradation of Materials	6cp
67607	Specialisation Projects in Metallurgy, Polymer Materials, Ceramics and Composite Materials (students to choose only one discipline)	8cp
67605	Design and Selection of Materials Electives	3cp 7cp

**Part-time program****Old Pass degree – NM02**

Students who commenced before 1997 and have progressed beyond Stage 2 will be allowed to follow the old course to the extent that the relevant subjects, as detailed in the 1997 *Faculty of Science Handbook*, are available. Where subjects have been discontinued alternative programs of study should be arranged in consultation with academic advisers from the Faculty of Science.

**Bachelor of Science (Honours) in Materials Science****New course code: NM06****Old course code: NM03 Bachelor of Applied Science (Honours) in Materials Science (for pre-1997 students)**

The new course is a one year full-time course, or equivalent part-time, which is taken after completing the Bachelor of Science in Materials Science or an equivalent course with an average grade of at least credit over the final third of the course. The Honours degree offers basic training in research and introduces students to advanced areas of study in materials science. The major component is a supervised individual research project which extends over the full duration of the course and normally takes the form of an experimental or analytical investigation undertaken in the laboratory.

Further details are provided in the general introduction to the Undergraduate Courses section of this handbook.

The old Bachelor of Applied Science (Honours) degree in Materials Science, which is expected to be discontinued in 1999, was a four-year full-time program, the first five stages of which were identical to the old Pass degree course. All students were initially admitted to the Pass degree and to gain entry to the Honours program students had to achieve a Weighted Average Mark (WAM) of at least 65 for subjects in Stages 3 and 4.

Students wishing to undertake Honours in 1998 should contact the Head of Department or Honours Course Coordinator for advice concerning projects available and the pattern of Honours most suitable for them.

**Full-time program****New Honours degree – NM06****Stage 1**

67854	Honours (Materials Science) (2 sem)	24cp
-------	-------------------------------------	------

**Stage 2**

67854	Honours (Materials Science) (2 sem)	24cp
-------	-------------------------------------	------



## Sandwich program

### Old Honours degree – NM03

Years 1 and 2

As for stages 1 – 4 of the old Pass degree (see 1997 Faculty of Science Handbook)

#### Stage 5

##### Autumn semester

67506	Technical Ceramics	6cp
67602	Surface Properties of Materials	4cp
68071	Applied Physics (Materials)	4cp
67507	Composites	4cp
65062	Extractive Metallurgy	6cp

#### Stage 6

##### Spring semester

67605	Design and Selection of Materials	3cp
67606	Corrosion and Degradation of Materials	6cp
67652	Advanced Materials and Characterisation	8cp
	Electives <sup>1</sup>	7cp

#### Stage 7

##### Autumn semester

67995	Industrial Training (Honours)	
67751	Honours Project Proposal	4cp

#### Stage 8

##### Spring semester

67851	Honours Project	20cp
-------	-----------------	------

<sup>1</sup> Electives should be selected from subjects offered at appropriate levels by other faculties within the University.

## Part-time program

### Old Honours degree – NM03

Part-time students who commenced prior to 1997 and who wish to undertake Honours in 1998 should contact the Head of Department or Honours Course Coordinator for advice.

## Bachelor of Science in Applied Physics

**New course code: NP05**

**Old course code: NP01 Bachelor of Applied Science in Physics (for pre-1997 students)**

The development of modern technology and its application in a wide variety of industries has created a demand for scientists who have a confident approach to applied problem solving, a deep understanding of the physical principles underlying systems, who are able to utilise modern equipment for measurement and control and are flexible and adaptable to changing job needs. Applied physics graduates meet this demand and find employment in a wide range of private industries and public authorities.

The early stages of the Pass degree course consist of the study of basic science subjects, with the remainder of the course placing an emphasis on measurement, and on the use and design of instrumentation for measurement and control. There is thus a focus on modern electronics and computers. Students who perform well in the Pass program may proceed to the Honours program in order to pursue their studies to more advanced levels.

The new Pass degree course consists of six stages of formal academic study and students also have the opportunity to undertake a professional/industrial experience program leading to the additional award of Diploma in Scientific Practice. Although the course may be completed by three years of full-time attendance if the professional/industrial experience component is not taken, all students are strongly encouraged to undertake the industrial experience program. Hence the common course patterns are four years of full-time enrolment, including one year of industrial experience; or six years of part-time attendance while concurrently employed in a relevant industry; or alternating periods of full-time study with similar periods of full-time relevant employment.

Full-time attendance involves approximately 24 hours each week at the University; this enables a full stage of the course to be completed in one semester.

Part-time attendance involves about 12 hours each week at the University; with this form of attendance the equivalent of a full stage may be completed in one year. It is expected that

employers will release part-time students for at least one half-day per week for attendance at classes. Students commonly attend the University for one half-day and three evenings each week, or for two half-days and two evenings each week.

### Full-time program

#### New degree – NP05

For students who commenced in 1997 or later.

##### Stage 1

###### Autumn semester

33190	Mathematical Modelling for Science	6cp
65101	Chemistry 1C	6cp
68101	Physics 1C	6cp
	<i>one of</i>	
66101	Earth Science 1	6cp
91311	Biology 1	6cp
91701	Medical Science 1	6cp

##### Stage 2

###### Spring semester

33290	Computing and Mathematics for Science	6cp
65201	Chemistry 2C	6cp
67101	Introduction to Materials	6cp
68201	Physics 2	6cp

##### Stage 3

###### Autumn semester

33390	Mathematics and Scientific Software	6cp
68314	Electronics	6cp
68311	Physics 3	6cp
68312	Applied Physics 1	6cp

##### Stage 4

###### Spring semester

33490	Computational Mathematics and Physics	6cp
68411	Physics 4	6cp
68412	Applied Physics 2	6cp
	Elective/second major	6cp

##### Stage 5

###### Autumn semester

68514	Electronics and Interfacing	6cp
68511	Quantum and Solid State Physics	6cp
68512	Applied Physics 3	6cp
	Elective/second major	6cp

##### Stage 6

###### Spring semester

68611	Electromagnetics and Optics	6cp
	Electives/second major	18cp

### Part-time program

#### New degree – NP05

For students who commenced in 1997 or later.

##### Stage 1

###### Autumn semester

65101	Chemistry 1C	6cp
68101	Physics 1C	6cp

###### Spring semester

33190	Mathematical Modelling for Science	6cp
65201	Chemistry 2C	6cp

##### Stage 2

###### Autumn semester

33290	Computing and Mathematics for Science	6cp
	<i>one of</i>	
66101	Earth Science 1	6cp
91311	Biology 1	6cp
91701	Medical Science 1	6cp

###### Spring semester

68201	Physics 2	6cp
67101	Introduction to Materials	6cp

##### Stage 3

###### Autumn semester

33390	Mathematics and Scientific Software	6cp
68311	Physics 3	6cp

###### Spring semester

33490	Computational Mathematics and Physics	6cp
68411	Physics 4	6cp

##### Stage 4

###### Autumn semester

68314	Electronics	6cp
68312	Applied Physics 1	6cp

###### Spring semester

68412	Applied Physics 2	6cp
	Elective/second major	6cp

##### Stage 5

###### Autumn semester

68514	Electronics and Interfacing	6cp
68512	Applied Physics 3	6cp

###### Spring semester

	Electives/second major	12cp
--	------------------------	------

## 54 UNDERGRADUATE COURSES

### Stage 6

---

#### Autumn semester

68511	Quantum and Solid State Physics	6cp
	Elective/second major	6cp

#### Spring semester

68611	Electromagnetics and Optics	6cp
	Elective/second major	6cp

### Sandwich program

#### Old Pass degree – NP01

For students who commenced before 1997.

#### Stages 1 – 2

---

See 1997 *Faculty of Science Handbook*.

### Stage 3

---

#### Autumn semester

31871	Computing for Science	3cp
33221	Engineering Mathematics 2A	3cp
68314	Electronics	6cp
68311	Physics 3	6cp
68312	Applied Physics 1	6cp

### Stage 4

---

#### Spring semester

33330	Physical Mathematics	3cp
51368	Written and Oral Reporting	2cp
68404	Electronics 2	3cp
68406	Computational Physics	4cp
68411	Physics 4	6cp
68412	Applied Physics 2	6cp

#### Autumn semester

68996	Industrial Training 1	
-------	-----------------------	--

#### Spring semester

68997	Industrial Training 2	
-------	-----------------------	--

### Stage 5

---

#### Autumn semester

68503	Materials Physics	3cp
68504	Microprocessors in Instrumentation	3cp
68508	Project A (2 sem)	3cp
68511	Physics 5	6cp
68516	Techniques of Materials Analysis	6cp
	<i>and</i>	
	Elective	3cp

### Stage 6

---

#### Spring semester

68508	Project A (2 sem)	3cp
68603	Applied Thermodynamics	3cp
68604	Principles of Instrumentation	3cp

68605	Transducers and Devices	3cp
68608	Project B	3cp
68611	Physics 6	6cp
	<i>and</i>	
	Elective	3cp

### Part-time program

#### Old Pass degree – NP01

Students who commenced before 1997 and have progressed beyond Stage 2 may be permitted to continue in the old course to the extent that the relevant subjects, as detailed in the 1997 *Faculty of Science Handbook*, are available. Where subjects have been discontinued alternative programs of study should be arranged in consultation with academic advisers from the Department of Applied Physics.

### Industrial Training

#### Old Pass degree – NP01

Industrial Training (I.T.) is a compulsory component of the old course and a mark and grade are given for each period of I.T. Full details on eligibility and procedures may be obtained from the Department of Applied Physics.

Assessment of I.T. is based on:

1. a diary provided to all students, which includes a section for workplace supervisors to make comments;
2. the academic supervisor's report (all students are allocated an I.T. Supervisor from among the staff of the Department of Applied Physics); and
3. the student's own report due at the end of semester.

### Project

#### Old Pass degree – NP01

The aim of the Project is to develop the student's ability to work independently or with minimum supervision in an area of some practical relevance. The work for the Project may be carried out at the University, at the student's place of employment, or at another approved location.

Before beginning the Project students normally should have completed Stage 4 of the course and at least one industrial period.

Students intending to enrol in the Project should choose their topic prior to the end of classes in the previous semester. Relevant information is placed on the 'Urgent Physics

Notices Board' several weeks prior to the end of semester. Information on what is expected of all students doing a project and on the assessment procedures is available from the Projects Coordinator (Dr G Anstis).

## Bachelor of Science (Honours) in Applied Physics

**New course code: NP06**

### Old course code: NP02 Bachelor of Applied Science (Honours) in Physics

The new course is a one year full-time course, or equivalent part-time, which is taken after completing the Bachelor of Science in Applied Physics or an equivalent course with an average grade of at least credit over the final third of the course. The Honours degree offers basic training in research and introduces students to advanced areas of study in applied physics. The major component is a supervised individual research project which extends over the full duration of the course and normally takes the form of an experimental or analytical investigation undertaken in the laboratory.

Further details are provided in the general introduction to the Undergraduate Courses section of this handbook.

The old Bachelor of Applied Science (Honours) degree in Physics, which is expected to be discontinued in 1999, was a four-year full-time program, the first five stages of which were identical to the old Pass degree course. All students were initially admitted to the Pass degree and to gain entry to the Honours program students had to achieve a Weighted Average Mark (WAM) of at least 65 for subjects in Stages 3 and 4, and fulfil other requirements as detailed in the 1997 *Faculty of Science Handbook* or from the Department of Applied Physics.

Students wishing to undertake Honours in 1998 should contact the Head of the Department of Applied Physics or the Honours Course Coordinator for advice concerning eligibility, selection and assessment procedures, and for information on projects available and the pattern of Honours most suitable for them.

## Full-time program

### New Honours degree – NP06

#### Stage 1

68854	Honours (Physics) (2 sem)	24cp
-------	---------------------------	------

#### Stage 2

68854	Honours (Physics) (2 sem)	24cp
-------	---------------------------	------

### Old Honours degree – NP02

#### Years 1 to 2

As for stages 1 – 4 of the old Pass degree.

#### Year 3

##### Autumn semester

68511	Physics 5 <sup>1</sup>	6cp
-------	------------------------	-----

##### Industrial requirements

68995	Industrial Training (Honours)	
-------	-------------------------------	--

##### Spring semester

68603	Applied Thermodynamics <sup>1</sup>	3cp
-------	-------------------------------------	-----

68604	Principles of Instrumentation <sup>1</sup>	3cp
-------	--	-----

68611	Physics 6 <sup>1</sup>	6cp
-------	------------------------	-----

and

	Elective	3cp
--	----------	-----

#### Year 4

##### Autumn semester

68503	Materials Physics <sup>1</sup>	3cp
-------	--------------------------------	-----

68504	Microprocessors in Instrumentation <sup>1</sup>	3cp
-------	---	-----

68556	Advanced X-ray Techniques	4cp
-------	---------------------------	-----

68557	Advanced Electron Microscopy Techniques	4cp
-------	---	-----

68858	Project (Honours) (2 sem)	12cp
-------	---------------------------	------

##### Spring semester

68553	Computer Modelling of Physical Systems	3cp
-------	--	-----

68652	Device Physics	6cp
-------	----------------	-----

68655	Advanced Solid State Physics	4cp
-------	------------------------------	-----

68858	Project (Honours) (2 sem)	12cp
-------	---------------------------	------

<sup>1</sup> Subjects taken in common with Pass students.

## Part-time program

### Old Honours degree – NP02

Part-time students who commenced prior to 1997 and who wish to undertake Honours in 1998 should contact the Head of the Department of Applied Physics or the Honours Course Coordinator for advice.

## Bachelor of Science in Applied Physics/Bachelor of Engineering in Electrical Engineering/ Diploma in Engineering Practice

**Course code: NP04**

**Old course code: NP03 Bachelor of Applied Science in Physics/Bachelor of Engineering in Electrical Engineering**

All students who commenced in 1997 will be required to transfer to this course.

Applied Physics focuses on the application of modern scientific techniques and strategic use of physics, and has the aim of advancing technology, increasing our understanding and control of the environment, improving quality in production, and providing solutions to industrial and medical problems. Electrical Engineering is a professionally oriented discipline which prepares students for careers in electrical power, electronic instrumentation and control, and optical and electrical communication. The two disciplines are thus interdependent and have many common elements.

The double degree will enable graduates to pursue careers as scientists or engineers. As engineers they will benefit from the emphasis on basic understanding and innovation, 'hands-on' experience with advanced scientific instrumentation and modelling skills that they experience and develop in the applied physics component. As scientists their experience in engineering studies will enable them to appreciate the importance of, and to have skills in, good design, the evaluation and testing of designs from performance, economic, social and environmental viewpoints, and their implementation into products and systems. Graduates will be particularly suited to the modern workplace with its need for multidisciplinary team-oriented projects and for clear communication of ideas through all levels from process worker to senior management.

Key industries and research areas open to graduates include: biomedical technology, energy and power, applied optics, communications, space and satellite technology, instrumentation and control, computer modelling and design, imaging,

electromagnetic systems and materials, physical and industrial mathematics, technology and environmental management, and management consulting.

### Sandwich program

#### Stage 1

##### Autumn semester

33130	Mathematical Modelling 1	6cp
48210	Engineering through History and towards Sustainable Futures	6cp
65101	Chemistry 1C	6cp
68101	Physics 1C	6cp

#### Stage 2

##### Spring semester

33230	Mathematical Modelling 2	6cp
48220	Informatics	6cp
65201	Chemistry 2C	6cp
68201	Physics 2	6cp

#### Stage 3

##### Autumn semester

48430	Software Development 1	6cp
68314	Electronics	6cp
68311	Physics 3	6cp
68312	Applied Physics 1	6cp

#### Stage 4

##### Spring semester

33490	Computational Mathematics and Physics	6cp
48230	Engineering Communication	6cp
48530	Circuit Analysis	6cp
68411	Physics 4	6cp

#### Stage 5

##### Autumn semester

48120	Review of Engineering Practice 1	6cp
48110	Engineering Experience 1	

#### Stage 6

##### Spring semester

48240	Uncertainties and Risk in Engineering	6cp
48540	Signals and Systems	6cp
68412	Applied Physics 2	6cp
68611	Electromagnetics and Optics	6cp

#### Stage 7

##### Autumn semester

48250	Engineering Economics and Finance	6cp
45163	Real-time Software and Interfacing	6cp
68511	Quantum and Solid State Physics	6cp
68512	Applied Physics 3	6cp

## Stage 8

**Spring semester**

48140	Review of Engineering Practice 2	6cp
48130	Engineering Experience 2	

## Stage 9

**Autumn semester**

48260	Engineering Management	6cp
48550	Power Systems	6cp
48451	Digital Systems	6cp
48570	Data Acquisition and Distribution	6cp

## Stage 10

**Spring semester**

48270	Technology Assessment	6cp
48560	Analogue and Digital Control	6cp
48561	Power Electronics	6cp
	Submajor/Elective	6cp

## Stage 11

**Autumn semester**

48006	Capstone Project	6cp
	Submajor/Elective	18cp

Subject descriptions for engineering subjects are available in the 1998 *Faculty of Engineering Handbook*.

## Bachelor of Health Science in Acupuncture

**Course code: P005**

The Bachelor of Health Science in Acupuncture provides the graduate with a professional entry level for the practice of acupuncture. Traditional Chinese Medicine is made up of two major branches: acupuncture and Chinese herbal medicine. This program is a companion course to the Bachelor of Health Science in Chinese Herbal Medicine that is also offered by the Faculty of Science through the Department of Health Sciences.

During the three-and-a-half years of full-time study required to complete the Pass level program, the student will study Traditional Chinese Medicine (TCM) theory and philosophical foundations, acupuncture techniques, moxibustion and *tuina* (Chinese massage), diagnosis, clinical skills, Western medical sciences appropriate to a primary contact health care practitioner, practice management and research methods.

Having completed the Pass program, selected students in the Bachelor of Health Science in

Acupuncture may have the opportunity to enter the Honours program or the combined degree: Bachelor of Health Science in Acupuncture/Bachelor of Arts in International Studies (Chinese major).

### Course structure

## Stage 1

**Autumn semester**

99560	Introduction to Traditional Chinese Medicine	6cp
99502	Foundations of Traditional Chinese Medicine	6cp
99561	Clinical Theory and Clinic – Level 1 (A&M)	3cp
99563	Health Sciences 1	6cp
51389	Professional Writing and Communication	3cp

## Stage 2

**Spring semester**

99564	The Physiology of Qi	4cp
99565	Point Location 1 (and Treatment Techniques)	6cp
99568	Clinic – Level 2 (A&M)	4cp
99570	Health Sciences 2	6cp
92167	Foundations of Helping and Caring	4cp

## Stage 3

**Autumn semester**

99571	Chinese Diagnostic System	5cp
99509	Special Points and Systems	5cp
99573	Clinic – Level 3 (A&M)	4cp
99539	Pathophysiology 1 (TCM)	6cp
91607	Research Methods 1	4cp

## Stage 4

**Spring semester**

99511	History and Philosophy of TCM	6cp
99576	Advanced Chinese Diagnosis	6cp
99541	Clinic – Level 4 (A&M) and Point Location 2	6cp
99540	Pathophysiology 2 (TCM)	6cp

## Stage 5

**Autumn semester**

99578	Microsystems	6cp
99579	Chinese Massage ( <i>Tuina</i> )	6cp
99582	Clinic – Level 5 & Advanced Treatment Techniques	6cp
99584	Clinical Features of Disease	6cp

**Stage 6****Spring semester**

99517	Project Workshops	3cp
91608	Research Methods 2	4cp
99585	Disease States	6cp
99521	Clinical Acupuncture	5cp
99588	Clinical Theory and Clinic – Level 6 (A&M)	6cp
99536	First Aid Certificate Course	no cp

**Stage 7****Autumn semester**

99590	Special Topics in TCM (Intermodal and Professional)	8cp
99591	Practice Management	4cp
99538	Clinical Internship	12cp <sup>1</sup>

<sup>1</sup> In Stage 7, 99527 Hospital Training in China (6cp) which is a one-month hospital internship in China is offered as an alternative to 50 per cent of 99538 Clinical Internship.

## Bachelor of Health Science in Acupuncture (Honours)

**Course code: P006**

**Admission**

Admission to the Honours program will be based on the student attaining a weighted average mark equal to, or greater than, 65 over the seven stages of the Pass degree program.

Each student applying for admission to the program will be invited to nominate an area of special interest in which they wish to carry out a research project and will be required to consult with relevant members of academic staff concerning the feasibility of their proposal. If the proposal is approved, and subject to the establishment of satisfactory supervisory arrangements, the student will be formally admitted to the program and will conduct their project according to the University's *Code of Practice for Supervisors and Honours Year Students*.

**Course structure****Stages 1 – 7**

As for Pass degree

**Stage 8**

99593	Honours Project	24cp
-------	-----------------	------

**Stage 9**

99593	Honours Project	24cp
-------	-----------------	------

## Bachelor of Health Science in Acupuncture/ Bachelor of Arts in International Studies

**Course code: NH01**

The combined degree program in Acupuncture and International Studies provides Acupuncture students with a greater exposure to, and understanding of, Chinese culture and a working knowledge of Chinese. The program should also make it more possible for Acupuncture graduates to practise outside Australia.

This course is a six-year degree program in which the study of Acupuncture is integrated with the China major of the International Studies program. Students spend the fifth year of study at a Chinese university. All existing arrangements for both the Bachelor of Health Science in Acupuncture and the Bachelor of Arts in International Studies apply equally to the combined degree program in Acupuncture and International Studies.

To graduate with a BHlthSc BA, a student will be required to have completed 272 credit points of study: 176 credit points in Acupuncture and 96 credit points in Chinese Studies. Of the 96 credit points in Chinese Studies, there will be 32 credit points (four subjects) of study of the Chinese language; 16 credit points (two subjects) of the study of contemporary China and its global context; and 48 credit points (two semesters) of In-country Study at a university or institution of higher education in China.

Students do not need to have previously studied Chinese to be able to successfully complete the program. All students are required to complete four consecutive semesters of study of Chinese Language and Culture before proceeding to China for an academic year of study. There are various classes available for students with different levels of language proficiency: from complete beginners, to HSC-level proficiency and more advanced.

**Course structure**

**Year 1**

---

**Stage 1**

99560	Introduction to Traditional Chinese Medicine	6cp
99502	Foundations of Traditional Chinese Medicine	6cp
99561	Clinical Theory and Clinic – Level 1 (A&M)	3cp
99563	Health Sciences 1	6cp
51389	Professional Writing and Communication	3cp

**Stage 2**

99564	The Physiology of Qi	4cp
99565	Point Location 1 (and Treatment Techniques)	6cp
99568	Clinic – Level 2 (A&M)	4cp
99570	Health Sciences 2	6cp
92167	Foundations of Helping and Caring	4cp

**Year 2**

---

**Stage 3**

99571	Chinese Diagnostic System	5cp
99509	Special Points and Systems	5cp
99573	Clinic – Level 3 (A&M)	4cp
99539	Pathophysiology 1 (TCM)	6cp
91607	Research Methods 1	4cp

**Stage 4**

99511	History and Philosophy of TCM	6cp
99576	Advanced Chinese Diagnosis	6cp
99541	Clinic – Level 4 (A&M) and Point Location 2	6cp
99540	Pathophysiology 2 (TCM)	6cp

**Year 3**

---

**Stage 5**

971111	Chinese Language and Culture 1	8cp
99516	Advanced Needle Techniques, Ex-Channel Point Location and Clinic – Level 5	5cp
99517	Independent Research Project Workshops	3cp
91604	Introductory Microbiology/ Pharmacology	4cp
99584	Clinical Features of Disease	4cp

**Stage 6**

972111	Chinese Language and Culture 2	8cp
99519	Advanced Acupuncture Principles	4cp
99521	Clinical Acupuncture	5cp
99522	Clinical Theory (Outpatient Clinic) and Clinic – Level 6	4cp
	First Aid Certificate course	0cp
	Elective	3cp

**Year 4**

---

**Stage 7**

973111	Chinese Language and Culture 3	8cp
99515	Advanced Chinese Massage	3cp
99525	Supervised Practice (Outpatient Clinic)	6cp
99526	Independent Research Project	7cp

**Stage 8**

974111	Chinese Language and Culture 4	8cp
976111	Contemporary China	8cp
99520	Disease States 1 and 2	8cp

**Year 5**

---

**Stage 9**

977110	In-country Study 1: China	24cp
--------	---------------------------	------

**Stage 10**

978110	In-country Study 2: China	24cp
--------	---------------------------	------

**Year 6**

---

**Stage 11**

50140	Modernisation and Social Change	8cp
99514	Microsystems and Special Methods of Treatment	5cp
99523	Disease States 3	4cp
99524	Specialist Lecture Topics	4cp
21816	Practice Management	3cp

**Stage 12**

99525	Supervised Practice (Outpatient Clinic)	6cp
99526	Independent Research Project	6cp
	<b>Total</b>	<b>272cp</b>



## Bachelor of Health Science in Chinese Herbal Medicine

### Course code: NH02

The Bachelor of Health Science in Chinese Herbal Medicine provides the graduate with a professional entry level for the practice of the herbal aspects of Traditional Chinese Medicine (TCM). TCM is made up of two major branches: acupuncture and Chinese Herbal Medicine (CHM). This program is a companion course to the Bachelor of Health Science in Acupuncture that is also offered by the Faculty of Science through the Department of Health Sciences.

During the three-and-a-half years of full-time study required to complete the Pass level program, the student will study TCM theory and philosophical foundations, Chinese herbs and herbal formulae, diagnosis, clinical skills, Western medical sciences appropriate to a primary contact health care practitioner, practice management and research methods.

Having completed the Pass program, selected students in the Bachelor of Health Science in Chinese Herbal Medicine may have the opportunity to enter the Honours program.

### Course structure

#### Stage 1

##### Autumn semester

99560	Introduction to Traditional Chinese Medicine	6cp
99502	Foundations of Traditional Chinese Medicine	6cp
99562	Clinical Theory and Clinic – Level 1 (CHM)	3cp
99563	Health Sciences 1	6cp
51389	Professional Writing and Communication	3cp

#### Stage 2

##### Spring semester

99566	Introduction to Botany	4cp
99567	Introduction to Chinese Herbal Medicine	6cp
99569	Clinic – Level 2 (CHM)	4cp
99570	Health Sciences 2	6cp
92167	Foundations of Helping and Caring	4cp

#### Stage 3

##### Autumn semester

99571	Chinese Diagnostic System	5cp
99572	Chinese Herbal Formulae	5cp
99574	Clinic – Level 3 (CHM)	4cp
99539	Pathophysiology 1 (TCM)	6cp
91607	Research Methods 1	4cp

#### Stage 4

##### Spring semester

99511	History and Philosophy of TCM	6cp
99576	Advanced Chinese Diagnosis	6cp
99577	Clinic – Level 4 (CHM) and Chinese Herbal Medicine Practice	6cp
99540	Pathophysiology 2 (TCM)	6cp

#### Stage 5

##### Autumn semester

99580	Pharmacognosy	6cp
99581	Chinese Herbal Medicine 1	6cp
99583	Clinic – Level 5 (CHM) and Chinese Herbal Medicine Practice	6cp
99584	Clinical Features of Disease	6cp

#### Stage 6

##### Spring semester

99517	Project Workshops	3cp
91608	Research Methods 2	4cp
99536	First Aid Certificate Course	0cp
99586	Chinese Herbal Medicine 2	6cp
99587	Clinical Chinese Herbalism	5cp
99589	Clinical Theory (Internship Clinic) and Clinic – Level 6 (CHM)	6cp

#### Stage 7

##### Autumn semester

99590	Special Topics in TCM (Intermodal and Professional)	6cp
99591	Practice Management	4cp
99592	Clinical Internship (CHM)	12cp <sup>1</sup>

<sup>1</sup> In Stage 7, 99527 Hospital Training in China (6cp) which is a one-month hospital internship in China is offered as an alternative to 50 per cent of 99592 Clinical Internship.

## Bachelor of Health Science in Chinese Herbal Medicine (Honours)

**Course code:** NH03

### Admission

Admission to this course will be based on the student attaining a weighted average mark equal to, or greater than, 65 over the seven stages of the Pass degree program.

Students applying for admission will be invited to nominate an area of special interest in which they wish to carry out a research project and will be required to consult with relevant members of academic staff concerning the feasibility of their proposal. If the proposal is approved, and subject to the establishment of satisfactory supervisory arrangements, the student will be formally admitted to the program and will conduct their project according to the University's *Code of Practice for Supervisors and Honours Year Students*.

### Course structure

#### Stages 1 – 7

As for Pass degree

#### Stage 8

99593	Honours Project	24cp
-------	-----------------	------

#### Stage 9

99593	Honours Project	24cp
-------	-----------------	------

## Bachelor of Medical Science

**Course code:** NH04

The Bachelor of Medical Science degree is designed to educate and train graduates for careers in both medical and health-related sciences. Following an initial program of studies in basic science, students specialise in a wide variety of medical and preclinical science areas structured to provide knowledge and understanding of the human body targeting its structure, function and disease processes both at a cellular, whole organ and behavioural level. In the intermediate and final years students will also select elective subjects to provide a major specialised strand. Elective strands will focus on either additional medical

science areas such as molecular biology, immunology, haematology and clinical biochemistry or other subjects appropriate to the vocationally oriented course described below.

### Employment opportunities

The purpose of the course is to provide students with a degree that equips them to work in pharmaceutical, pathology and biomedical industries; biotechnology companies; medical research in research institutes, hospitals, industry and universities; and other health-related professions at both State and federal levels. In addition to employment in these areas graduates will also have the background knowledge and skills that are necessary for entry into graduate medical degrees as well as for preparing them for other vocationally oriented courses in the areas of occupational health and safety, biomedical engineering, nutrition and dietetics, osteopathy, public health and health administration. In addition, Honours, Master's and Doctoral programs by research are available for graduates who show an aptitude for independent research work.

### Course structure

The course consists of six stages offered on a full-time attendance basis only. Subjects are divided into core subjects and elective subjects, some of which may form a coherent second major strand. All students enrolled in the course must satisfactorily complete a total of 40 credit points of elective/second major subjects for award of the degree. Students generally choose these subjects with a particular theme or area of expertise in mind, such as a particular area of study, through subjects available within the biological and biomedical sciences, or by way of subjects from other parts of the Faculty of Science or other faculties of UTS including Humanities and Social Sciences, Engineering, Nursing, Business, Law, or the Institute of International Studies. It should be noted that timetable constraints may prevent the undertaking of some combinations.

#### Stage 1

##### Autumn semester

33101	Mathematics 1 (LS)	3cp
33106	Statistical Design and Analysis (2 sem)	3cp
65101	Chemistry 1C	6cp
68041	Physics 1A	6cp
91701	Medical Science 1	6cp

**Stage 2****Spring semester**

33106	Statistical Design and Analysis (2 sem)	3cp
65201	Chemistry 2C	6cp
91395	Biocomputing	3cp
91702	Medical Science 2	6cp
	<i>one of</i>	
68201	Physics 2	6cp
91312	Biology 2	6cp
	<i>or</i>	
	Other approved subject	6cp

**Stage 3****Autumn semester**

91313	Biochemistry 1	6cp
91703	Physiological Systems	6cp
	Electives/ second major	12cp

**Stage 4****Spring semester**

91704	Behavioural Sciences	6cp
91705	Medical Devices and Diagnostics	6cp
	Electives/ second major	12cp

**Stage 5****Autumn semester**

91706	Neuroscience	8cp
91707	Pharmacology 1	8cp
	Electives/ second major	8cp

**Stage 6****Spring semester**

91708	Psychophysiology	8cp
91709	Pharmacology 2	8cp
	Electives/ second major	8cp

**Bachelor of Science  
(Honours)****Course code: KB04****Admission**

The Honours course is open to students who possess, or have fulfilled, all the requirements for a three-year Bachelor's degree in Biomedical Science, Biotechnology, Environmental Biology, Environmental and Urban Horticulture or Medical Science from UTS, or equivalent qualification, with at least an average credit grade in the final two stages of the undergraduate program.

**Aims**

An Honours program gives basic training in biological or biomedical research. Students may then enter occupations for which an Honours degree is the minimum requirement or continue with postgraduate research.

**Attendance patterns and  
course requirements**

The course is offered as a full-time program over two semesters. The research project, which is the major component of the course and extends over both semesters, normally takes the form of an experimental or analytical investigation, undertaken either in the laboratory or in the field. The course also requires students to undertake two critical reviews of the scientific literature in designated areas. The project work is in an area of biomedical science (biochemistry, molecular biology, immunology, pathology or microbiology), biotechnology, physiology (neuro or cardiac), environmental biology (including environmental toxicology and coastal resource management) or urban horticulture, and the results are presented in an oral seminar and in a written report, both of which are formally assessed.

**Other information**

Information concerning the method of application, starting dates and other relevant matters is provided at the beginning of the Undergraduate courses section of this handbook.

## Course structure

### Full-time program

Year 1 – Stages 1 and 2

#### Autumn and Spring semesters

91304 Honours (Biological and Biomedical Sciences) 48cp

### Part-time program

Year 1 – Stages 1 and 2

#### Autumn and Spring semesters

91305 Honours (Biological and Biomedical Sciences) (2yrs) 24cp

Year 2 – Stages 3 and 4

#### Autumn and Spring semesters

91305 Honours (Biological and Biomedical Sciences) (2yrs) 24cp

## Bachelor of Science in Biomedical Science

### Course code: KB02

The Biomedical Science degree consists of an initial program of biology, chemistry, physics, mathematics, statistics and computing followed by microbiology, biochemistry, pathology, immunology and molecular biology. Students then complete the third year of the course by undertaking a number of elective subjects, totalling a minimum of 48 credit points. At least half of these must be biomedical science electives covering more advanced biomedical aspects of the second-year core subjects or introducing a range of important areas of applied biomedical science.

The opportunity also exists for students to undertake a range of second majors or free electives in disciplines outside biomedical science.

The undergraduate training provides a solid background in the physical sciences and emphasises practical experimentation. In the final stages of the course, research activities are encouraged through project assignments. Students acquire familiarity with advanced instruments and technology. They are encouraged to participate in seminar activities. The purpose of the course is to educate people in a number of interface areas between modern technology, biology and medicine.

## Employment opportunities

A wide range of employment opportunities is available to graduates. Biomedical scientists work closely with clinical pathologists, surgeons and other medical specialists in the control and elimination of disease. There is a demand for biomedical scientists in the Commonwealth and State health departments, the Repatriation Department, CSIRO, universities, pharmaceutical firms, veterinary laboratories and private pathology laboratories.

Graduates from this course who have completed studies in relevant clinical areas will be eligible for membership of the Australian Institute of Medical Scientists (AIMS). Further advice may be obtained from the Head of the Department of Cell and Molecular Biology.

## Course structure

Students can complete the degree in three years full time or six years part time or by a combination of both these attendance patterns. The full-time course may be extended by up to one year for students who elect to take the professional/industrial experience program leading to the additional award of Diploma in Scientific Practice.

Subjects are divided into core subjects and elective subjects, some of which may form a coherent second major strand. All students enrolled in the degree must satisfactorily complete all core subjects for award of the degree and, in addition, must satisfactorily complete the required number of credit points of elective/second major subjects. Students generally choose these subjects with a particular theme or area of expertise in mind. Recommended electives are given in the Elective Options Table, and recommended combinations of subjects are listed for the guidance of students. It should be noted that timetable constraints may prevent the undertaking of some elective combinations.

## Full-time program

### Stage 1

#### Autumn semester

33101	Mathematics 1 (LS)	3cp
33106	Statistical Design and Analysis (2 sem)	3cp
65012	Chemistry 1A	6cp
91701	Medical Science 1	6cp
68041	Physics 1A	6cp

**Stage 2****Spring semester**

33106	Statistical Design and Analysis (2 sem)	3cp
65022	Chemistry 2A	6cp
91395	Biocomputing	3cp
91702	Medical Science 2	6cp
	<i>one of</i>	
68201	Physics 2	6cp
91312	Biology 2	6cp
	<i>or</i>	
	Other approved science subject	6cp

**Stage 3****Autumn semester**

91313	Biochemistry 1	6cp
91314	Microbiology 1	6cp
91354	Anatomical Pathology	6cp
	Elective/second major	6cp

**Stage 4****Spring semester**

91320	Biochemistry 2	6cp
91326	Analytical Biochemistry	6cp
91330	Microbiology 2	6cp
	Elective/second major	6cp

**Stage 5****Autumn semester**

	Biomedical Science Electives <sup>1</sup>	16cp
	Elective/second major	8cp

**Stage 6****Spring semester**

	Biomedical Science Electives <sup>1</sup>	8cp
	Electives/second major	16cp

<sup>1</sup> For details of electives available for the Biomedical Science degree, see Biomedical Science Elective Options Table.

**Part-time program****Stage 1****Autumn semester**

65012	Chemistry 1A	6cp
91701	Medical Science 1	6cp

**Spring semester**

65022	Chemistry 2A	6cp
91702	Medical Science 2	6cp

**Stage 2****Autumn semester**

33101	Mathematics 1 (LS)	3cp
33106	Statistical Design and Analysis (2 sem)	3cp
68041	Physics 1A	6cp

**Spring semester**

33106	Statistical Design and Analysis (2 sem)	3cp
91395	Biocomputing	3cp
	<i>one of</i>	
68201	Physics 2	6cp
91312	Biology 2	6cp
	<i>or</i>	
	Other approved science subject	6cp

**Stages 3 and 4 – in 1998 and even years****Autumn semester**

91313	Biochemistry 1	6cp
	Elective/second major	6cp

**Spring semester**

91320	Biochemistry 2	6cp
91326	Analytical Biochemistry	6cp

**Stages 3 and 4 – in 1999 and odd years****Autumn semester**

91314	Microbiology 1	6cp
91354	Anatomical Pathology	6cp

**Spring semester**

91330	Microbiology 2	6cp
	Elective/second major	6cp

**Stage 5****Autumn semester**

	Biomedical Science Electives <sup>1</sup>	16cp
--	---	------

**Spring semester**

	Biomedical Science Electives <sup>1</sup>	8cp
--	---	-----

**Stage 6****Autumn semester**

	Elective/second major	8cp
--	-----------------------	-----

**Spring semester**

	Electives/second major	16cp
--	------------------------	------

<sup>1</sup> For details of electives available for the Biomedical Science degree, see Biomedical Science Elective Options Table.

**Notes:** The order in which part-time students undertake Stage 3, 4, 5 and 6 subjects, is determined by the fact that subjects are offered in appropriate time slots in alternate years only. Students entering the program in even and odd years will take their preferred combination of subjects in a different sequence.

## Biomedical Science Elective Options Table

Subject Number	Subject Name	Credit points	Sem A/S	Recommended stage for subject <sup>1</sup>
91703	Physiological Systems	6	A	3
91706	Neuroscience	8	S	6
91351	Immunology 1	3	S	4
91355	Haematology 1	3	S	4
91331	Microbiology 3	8	A	5 e
91332	Molecular Biology 1	8	A	5 o
91344	Clinical Biochemistry 1	8	A	5 e
91358	Haematology 2	8	A	5 o
91335	Molecular Biology 2	8	S	6 o
91338	Clinical Bacteriology	8	S	6 e
91340	Transfusion Science	8	S	6 o
91345	Clinical Biochemistry 2	8	S	6 e
91352	Eukaryotic Microbiology	8	S	6 o
91359	Immunology 2	8	S	6 e
91377	Cytopathology	16	Full Year	5&6 e
91398	Special Reading Assignment LS <sup>2</sup>	4	A&S	5 or 6
91399	Individual Project LS <sup>2</sup>	8	A&S	5&6
xxxxx	Miscellaneous elective <sup>3</sup>	4	A&S	5 or 6

### Key:

A = Timetabled in Autumn semester

S = Timetabled in Spring semester

LS = Life Sciences

- <sup>1</sup> From 1999 onwards, the Stage 5 and 6 subjects marked (o) will run in part-time mode in odd-numbered years only; those marked (e) will run in part-time mode in even numbered years only.
- <sup>2</sup> Supervision form must be completed and approved by the Course Coordinator.
- <sup>3</sup> This may include subjects from other courses within the biological and biomedical sciences, subjects from another UTS school or faculty or subjects from another university undertaken on a cross-institution enrolment basis: e.g. Viruses and Disease at UNSW. Programs that include more than 4cp of miscellaneous subjects require approval of the Associate Dean (Coursework Programs).

**Note:** Subjects recommended for particular stages can be undertaken by part-time students when programmable provided the prerequisites are met. Owing to timetabling constraints, not all electives may be available to all students in any given semester.

## Recommended subject strands

Completion of any combination of subjects totalling a minimum of 24 credit points from the table of approved biomedical science electives, plus another 24 credit points of electives/second major subjects which may be drawn from the table or from another part of the Faculty or elsewhere in the University, will fulfil the requirements of Stages 5 and 6 of the Biomedical Science degree course. However, it is strongly recommended that students include at least one of the following combinations of subjects in their programs. Each combination constitutes a cohesive strand of study in a particular discipline or related disciplines.

### Biochemistry strand

#### Stage 5

91332	Molecular Biology 1	8cp
91344	Clinical Biochemistry 1	8cp
	<i>plus</i>	
	Additional electives	8cp

#### Stage 6

91335	Molecular Biology 2	8cp
91345	Clinical Biochemistry 2	8cp
	<i>plus</i>	
	Additional electives	8cp

### Microbiology strand

#### Stage 5

91331	Microbiology 3	8cp
91332	Molecular Biology 1	8cp
	<i>plus</i>	
	Additional electives	8cp

#### Stage 6

91338	Clinical Bacteriology	8cp
91352	Eukaryotic Microbiology	8cp
	<i>plus</i>	
	Additional electives	8cp

### Pathology strand

#### Stage 5

91358	Haematology 2	8cp
91377	Cytopathology (2 sem)	8cp
	<i>plus</i>	
	Additional electives	8cp

#### Stage 6

91340	Transfusion Science	8cp
91377	Cytopathology (2 sem)	8cp
	<i>plus</i>	
	Additional electives	8cp

### Immunology strand

#### Stage 5

91332	Molecular Biology 1	8cp
	<i>plus</i>	
	Additional electives	16cp

#### Stage 6

91335	Molecular Biology 2	8cp
91359	Immunology 2	8cp
	<i>plus</i>	
	Additional electives	8cp

## Bachelor of Science in Biotechnology

### Course code: KB06

The Bachelor of Science in Biotechnology is fully recognised for membership of both the Australian Institute of Biology Inc. and the Australian Society for Microbiology, as well as being for a professional qualification with emphasis on DNA technology and its applications. The course encompasses basic sciences plus microbiology, biochemistry, immunology, industrial biotechnology and molecular biology. At the completion of the course students will have acquired a sound background in industrial microbiology, and competence in a wide range of standard biological, microbiological and biochemical laboratory techniques.

### Employment opportunities

Today's biotechnologist has an expanding variety of career opportunities, and graduates from this degree can expect to find employment opportunities in the food, beverage, chemical, pharmaceutical and fermentation industries, particularly in production, quality control, or research and development areas. These industries depend on a high level of professional competence in standard techniques of microbiology and biochemistry. An increasing number of products involve the application of some of the molecular or other aspects of biotechnology in their manufacture. A variety of research and development opportunities exist e.g. AIDS research, or the production of transformed plants or animals with designer genes. Good employment opportunities also exist with State and Federal Government scientific instrumentalities, and in research and other laboratories in tertiary institutions, hospitals

and industry. In recent years a number of smaller, specialised development and consulting companies have developed from biotechnology research programs. These organisations require graduates with a strong basis in biotechnology and applied microbiology. Many employers in the biotechnology field, being themselves active in research and development, have close links with tertiary education institutions, and can offer graduates the possibility of higher degree studies in conjunction with employment.

### Course structure

Students can complete the degree in three years full time or six years part time or by a combination of both these attendance patterns. The full-time course may be extended by up to one year for students who elect to take the professional/industrial experience program leading to the additional award of Diploma in Scientific Practice.

Subjects are divided into core subjects and elective subjects, some of which may be combined to form a coherent second major strand. All students enrolled in the degree must satisfactorily complete all core subjects for award of the degree and, in addition, must satisfactorily complete a total of 34 credit points of elective/second major subjects. Students generally choose these subjects with a particular theme or area of expertise in mind. Examples of recommended electives are given in the Elective Options Table; however, it should be noted that timetable constraints may prevent the undertaking of some elective combinations.

**Elective/second major combinations** include a particular area of study by subjects available from within the biological and biomedical sciences, or by subjects from other parts of the Faculty of Science, other faculties or institutes of UTS, or, with the approval of the Associate Dean, other universities.

### Full-time program

#### Stage 1

##### Autumn semester

33101	Mathematics 1 (LS)	3cp
33106	Statistical Design and Analysis (2 sem)	3cp
65012	Chemistry 1A	6cp
68041	Physics 1A	6cp
91701	Medical Science 1	6cp

#### Stage 2

##### Spring semester

33106	Statistical Design and Analysis (2 sem)	3cp
65022	Chemistry 2A	6cp
91395	Biocomputing	3cp
91702	Medical Science 2	6cp
	<i>one of</i>	
68201	Physics 2	6cp
91312	Biology 2	6cp
	<i>or</i>	
	Other approved science subject	6cp

#### Stage 3

##### Autumn semester

91313	Biochemistry 1	6cp
91314	Microbiology 1	6cp
	Electives <sup>1</sup> /second major	12cp

#### Stage 4

##### Spring semester

91325	Principles and Practice of Biotechnology	3cp
91326	Analytical Biochemistry	6cp
91330	Microbiology 2	6cp
91351	Immunology 1	3cp
	Elective <sup>1</sup> /second major	6cp

#### Stage 5

##### Autumn semester

91332	Molecular Biology 1	8cp
91369	Applied and Environmental Microbiology	8cp
	Electives <sup>1</sup> /second major	8cp

#### Stage 6

##### Spring semester

91335	Molecular Biology 2	8cp
91368	Bioprocessing	8cp
	Electives <sup>1</sup> /second major	8cp

<sup>1</sup> For details of the electives available for the Biotechnology degree, see Elective Options Table.

### Part-time program

#### Stage 1

##### Autumn semester

65012	Chemistry 1A	6cp
91701	Medical Science 1	6cp

##### Spring semester

65022	Chemistry 2A	6cp
91702	Medical Science 2	6cp



## Stage 2

**Autumn semester**

33101	Mathematics 1 (LS)	3cp
33106	Statistical Design and Analysis (2 sem)	3cp
68041	Physics 1A	6cp

**Spring semester**

33106	Statistical Design and Analysis (2 sem)	3cp
91395	Biocomputing	3cp
	<i>one of</i>	
68201	Physics 2	6cp
91312	Biology 2	6cp
	<i>or</i>	
	Other approved science subject	6cp

## Stages 3 and 4 – in 1998 and even years

**Autumn semester**

91313	Biochemistry 1	6cp
	Elective <sup>1</sup> /second major	6cp

**Spring semester**

91326	Analytical Biochemistry	6cp
	Elective <sup>1</sup> /second major	6cp

## Stages 3 and 4 – in 1999 and odd years

**Autumn semester**

91314	Microbiology 1	6cp
	Elective <sup>1</sup> /second major	6cp

**Spring semester**

91330	Microbiology 2	6cp
91351	Immunology 1	3cp
91325	Principles and Practice of Biotechnology	3cp

## Stage 5

**Autumn semester**

91332	Molecular Biology 1	8cp
	Electives <sup>1</sup> /second major	8cp

**Spring semester**

91335	Molecular Biology 2	8cp
-------	---------------------	-----

## Stage 6

**Autumn semester**

91369	Applied and Environmental Microbiology	8cp
-------	---	-----

**Spring semester**

91368	Bioprocessing	8cp
	Electives/second major	8cp

<sup>1</sup> For details of the electives available for the Biotechnology degree, see Elective Options Table.

**Note:** Some electives for part-time students are offered in alternate years only. Students entering the program in even and odd years will take their preferred combination of electives in a different sequence. The order in which part-time students undertake Stage 3, 4, 5 and 6 subjects is determined by the fact that subjects are offered in appropriate time slots in alternate years only.

**Elective Options Table for Biotechnology course**

Subject Number	Subject Name	Credit points	Sem A/S	Recommended stage for subject <sup>1</sup>
91315	Biomonitoring	3	A	3
91320	Biochemistry 2	6	S	4
91324	Environmental Toxicology	8	S	6
91331	Microbiology 3	8	A	5 e
91327	Environmental Management Procedures	8	S	6
91338	Clinical Bacteriology	8	S	6 e
91347	Toxic Materials in the Environment	4	S	6
91352	Eukaryotic Microbiology	8	S	6 o
91359	Immunology 2	8	S	6 e
91375	Field Studies: Marine Science	4	A&S	5 or 6
91376	Environmental Measurement	3	A	3
91398	Special Reading Assignment <sup>1</sup>	4	A&S	5 or 6
91399	Individual Project LS <sup>2</sup>	8	A&S	5 or 6
91703	Physiological Systems	6	A	3
91707	Pharmacology 1	8	A	5
91709	Pharmacology 2	8	S	6
xxxxx	Miscellaneous elective <sup>3</sup>	4&8	A&S	3 – 6

**Key:**

A = Timetabled in Autumn semester

S = Timetabled in Spring semester

LS = Life Sciences

- <sup>1</sup> From 1999 onwards, the subjects marked (o) will run in part-time mode in odd-numbered years only; those marked (e) will run in part-time mode in even-numbered years only.
- <sup>2</sup> Supervision form must be completed and approved by the Course Coordinator.
- <sup>3</sup> This may include subjects from other courses within the biological and biomedical sciences, subjects from another UTS school or faculty or subjects from another university undertaken on a cross-institution enrolment basis: e.g. Viruses and Disease at UNSW. Programs that include more than 4cp of miscellaneous subjects require approval of the Associate Dean (Coursework Programs).

**Note:** Subjects recommended for particular stages can be undertaken by part-time students when programmable provided the prerequisites are met. Owing to timetabling constraints, not all electives may be available to all students in any given semester.

## Bachelor of Science in Environmental Biology

### Course code: KB05

The Bachelor of Science in Environmental Biology is fully recognised for membership of the Australian Institute of Biology Inc. and fully qualifies graduates as biological scientists with specialisation in environmental science.

The course provides a degree in biological science and the advanced technological skills to tackle complex environmental problems such as an ability to apply sampling and measurement methods for such purposes as pollution monitoring or the preparation of environmental assessments. After foundation studies in the basic sciences, students will specialise in the ecology and physiology of plants, animals and micro-organisms, and in freshwater, marine and terrestrial ecosystems. Students will also have the opportunity to take part in field trips to many parts of the State, for example north and south coastal areas, Snowy Mountains, the Murrumbidgee Irrigation Area, the far west and Jervis Bay. Students should note that excursions for field study elective subjects may be held in the weeks prior to semester and in other non-teaching weeks during the year. In 1998, the excursions for the subjects Aquatic Ecology and Terrestrial Ecosystems will be held in February. An excursion to Jervis Bay (as part of Field Studies: Marine Sciences) is also offered during February and/or July of each year. Students should consult with lecturers before annual recess.

### Employment opportunities

Graduates of the course may be employed as scientific officers with government agencies such as the Water Board, Environment Protection Authority, Departments of Environment, Fisheries, CaLM Planning, National Parks and Wildlife Service, museums and herbaria; with local government authorities; or as technical and research officers with universities and colleges; or as environmental consultants, or environmental, toxicological or biological scientists in private enterprise. Many organisations provide opportunities for graduates to undertake research projects for a higher degree in the Faculty.

### Course structure

Students can complete the degree in three years full time or six years part time or by a combination of both attendance patterns. The full-time course may be extended by up to one year for students who elect to take the professional/industrial experience program leading to the additional award of Diploma in Scientific Practice.

Subjects are divided into core subjects and elective subjects. All students enrolled in the degree must satisfactorily complete all core subjects for award of the degree, and, in addition, must satisfactorily complete a total of 38 credit points of elective subjects, some of which may be combined to form a coherent second major strand. Students generally choose these subjects with a particular theme or area of expertise in mind. Examples of recommended electives are given in the Elective Options Table; however, it should be noted that timetable constraints may prevent the undertaking of some elective combinations.

**Elective/second major combinations** include a particular area of study by subjects available from within the biological and biomedical sciences, or by subjects from other parts of the Faculty of Science, other faculties or institutes of UTS, or, with the approval of the Associate Dean, other universities.

### Full-time program

#### Stage 1

##### Autumn semester

33101	Mathematics 1 (LS)	3cp
33106	Statistical Design and Analysis (2 sem)	3cp
65012	Chemistry 1A	6cp
91311	Biology 1	6cp
	<i>one of</i>	
66101	Earth Science 1	6cp
68041	Physics 1A	6cp
91231	Horticulture 1	6cp
	<i>or</i>	
	Other approved science subject	6cp

#### Stage 2

##### Spring semester

33106	Statistical Design and Analysis (2 sem)	3cp
65022	Chemistry 2A	6cp
91312	Biology 2	6cp
91395	Biocomputing	3cp
	<i>one of</i>	
66204	Field Studies 1	6cp

68041	Physics 1A	6cp
68201	Physics 2	6cp
	<i>or</i>	
	Other approved science subject	6cp

**Stage 3**

**Autumn semester**

91270	Plant Physiology	6cp
91303	Experimental Design in Ecology	3cp
91329	Ecological Sampling	3cp
	Electives <sup>1</sup> /second major	12cp

**Stage 4**

**Spring semester**

91307	Community and Population Ecology	3cp
91308	Australian Soils	3cp
91309	Australian Biota	6cp
91363	Animal Ecophysiology	6cp
	Elective <sup>1</sup> /second major	6cp

**Stage 5**

**Autumn semester**

91306	Terrestrial Ecosystems	4cp
91318	Ecological Modelling	4cp
91323	Mapping and Remote Sensing	4cp
91364	Aquatic Ecology	8cp
	Elective <sup>1</sup> /second major	4cp

**Stage 6**

**Spring semester**

91324	Environmental Toxicology	8cp
	Electives <sup>1</sup> /second major	16cp

<sup>1</sup> For details of the electives available for the Environmental Biology degree, see Elective Options Table.

**Part-time program**

**Stage 1**

**Autumn semester**

65012	Chemistry 1A	6cp
91311	Biology 1	6cp

**Spring semester**

65022	Chemistry 2A	6cp
91312	Biology 2	6cp

**Stage 2**

**Autumn semester**

33101	Mathematics 1 (LS)	3cp
33106	Statistical Design and Analysis (2 sem)	3cp
	<i>one of</i>	
66101	Earth Science 1	6cp
68041	Physics 1A	6cp
	<i>or</i>	
	Other approved science subject	6cp

**Spring semester**

33106	Statistical Design and Analysis (2 sem)	3cp
91395	Biocomputing	3cp
	<i>one of</i>	
66204	Field Studies 1	6cp
68041	Physics 1A	6cp
68201	Physics 2	6cp
	<i>or</i>	
	Other approved science subject(s)	6cp

**Stages 3 and 4 – in 1998 and even years**

**Autumn semester**

91303	Experimental Design in Ecology	3cp
91329	Ecological Sampling	3cp
	Elective <sup>1</sup> /second major	6cp

**Spring semester**

91307	Community and Population Ecology	3cp
91308	Australian Soils	3cp
	Elective <sup>1</sup> /second major	6cp

**Stages 3 and 4 – in 1999 and odd years**

**Autumn semester**

91270	Plant Physiology	6cp
	Elective <sup>1</sup> /second major	6cp

**Spring semester**

91309	Australian Biota	6cp
91363	Animal Ecophysiology	6cp

**Stages 5 and 6 – in 1998 and even years**

**Autumn semester**

91318	Ecological Modelling	4cp
91323	Mapping and Remote Sensing	4cp
	Elective <sup>1</sup> /second major	4cp

**Spring semester**

91324	Environmental Toxicology	8cp
	Elective <sup>1</sup> /second major	4cp

**Stages 5 and 6 – in 1999 and odd years**

**Autumn semester**

91306	Terrestrial Ecosystems	4cp
91364	Aquatic Ecology	8cp

**Spring semester**

	Electives <sup>1</sup> /second major	12cp
--	--------------------------------------	------

<sup>1</sup> For details of the electives available for the Environmental Biology degree, see Elective Options Table.

**Note:** Subjects for part-time students may be offered in a different order or combination in any one year. Students should note that excursions may be held in the weeks prior to semester.

## Bachelor of Science in Environmental and Urban Horticulture

### Course code: KB03

The Bachelor of Science in Environmental and Urban Horticulture is fully recognised for membership of the Australian Institute of Biology Inc. and the Australian Institute of Horticulture Inc. as a professional qualification in plant science and as a specialist qualification in ornamental and amenity, landscape and environmental horticulture.

The course provides students with a sound background in plant science and horticultural management. After introductory studies in horticulture and foundation studies in the basic sciences, students will specialise in plant science. Areas studied include plant structure, physiology, ecology, genetics and soil science. As there is a particular emphasis on ornamental and amenity horticulture, students also undertake studies in plant cultivation, protection, breeding and Australian plants. Horticultural management is studied in relation to financial management, plant production systems and open space areas.

Excursions will be undertaken in the Sydney metropolitan area and other parts of the State. Students should note that excursions may be held in the weeks prior to semester and in other non-teaching weeks during the semester. In 1998, for example, the Terrestrial Ecosystems excursion will be held in February prior to formal classes.

### Employment opportunities

Graduates of the course are in increasing demand as professional horticulturists. As an urban horticulturist you might be a researcher in a plant sciences laboratory; work on the selection and breeding of new ornamental varieties, including Australian native species; be responsible for the planning and management of nursery production, park and recreation areas; or be responsible for the revegetation and management of natural areas disturbed by human impact. Many graduates also enter universities and research organisations.

### Course structure

Students can complete the degree in three years full time or six years part time or a combination of both attendance patterns. The

full-time course may be extended by up to one year for students who elect to take the professional/industrial experience program leading to the additional award of Diploma in Scientific Practice.

The undergraduate program emphasises practical experimentation, and research activities are encouraged through project assignments. The students acquire familiarity with advanced instruments and technology, and are encouraged to participate in seminar activities. The course was developed in close liaison with all branches of the industry and with the Horticulture School of the Ryde College of TAFE, and students who enter with an Associate Diploma in Horticulture or equivalent qualification are granted exemptions from a number of subjects.

Subjects are divided into core subjects and elective subjects, some of which may be combined to form a coherent second major strand. All students enrolled in the degree must satisfactorily complete all core subjects for award of the degree and, in addition, must satisfactorily complete a total of 37 credit points of elective/second major subjects. Students generally choose these subjects with a particular theme or area of expertise in mind. Examples of recommended electives are given in Elective Options Table; however, it should be noted that timetable constraints may prevent the undertaking of some elective combinations.

**Elective/second major combinations** include a particular area of study by subjects available from within the biological and biomedical sciences, or by subjects from other parts of the Faculty of Science, other faculties or institutes of UTS, or, with the approval of the Associate Dean, other universities.

### Full-time program

#### Stage 1

##### Autumn semester

33106	Statistical Design and Analysis (2 sem)	3cp
65012	Chemistry 1A	6cp
91230	Landscape Design	3cp
91231	Horticulture 1	6cp
91311	Biology 1	6cp

#### Stage 2

##### Spring semester

33106	Statistical Design and Analysis (2 sem)	3cp
65022	Chemistry 2A	6cp
91232	Horticulture 2	6cp

91312	Biology 2	6cp
91395	Biocomputing	3cp

**Stage 3**

**Autumn semester**

91233	Plant Production and Growth Media	6cp
91270	Plant Physiology	6cp
	Electives <sup>1</sup> /second major	12cp

**Stage 4**

**Spring semester**

91234	Uses of Australian Plants	6cp
91237	Plant Pathology	6cp
91308	Australian Soils	3cp
	Electives <sup>1</sup> /second major	9cp

**Stage 5**

**Autumn semester**

91207	Plants in the Landscape	8cp
91229	Horticultural Financial Management	4cp
91236	Plant Tissue Culture	4cp
	Electives <sup>1</sup> /second major	8cp

**Stage 6**

**Spring semester**

91224	Horticultural Production Management	4cp
91225	Open Space Management	4cp
91271	Plant Genetics and Breeding	8cp
	Electives <sup>1</sup> /second major	8cp

<sup>1</sup> For details of the electives available for the Urban Horticulture degree, see Elective Options Table.

**Note:** Students should note that excursions for field study elective subjects may be held in the weeks prior to semester and in other non-teaching weeks during the year.

**Part-time program**

**Stage 1**

**Autumn semester**

91231	Horticulture 1	6cp
91311	Biology 1	6cp

**Spring semester**

91232	Horticulture 2	6cp
91312	Biology 2	6cp

**Stage 2**

**Autumn semester**

33106	Statistical Design and Analysis (2 sem)	3cp
65012	Chemistry 1A	6cp
91230	Landscape Design	3cp

**Spring semester**

33106	Statistical Design and Analysis (2 sem)	3cp
65022	Chemistry 2A	6cp
91395	Biocomputing	3cp

**Stages 3 and 4 – in 1998 and even years**

**Autumn semester**

91233	Plant Production and Growth Media	6cp
	Electives <sup>1</sup> /second major	6cp

**Spring semester**

91237	Plant Pathology	6cp
91308	Australian Soils	3cp
	Elective <sup>1</sup> /second major	3cp

**Stages 3 and 4 – in 1999 and odd years**

**Autumn semester**

91270	Plant Physiology	6cp
	Electives <sup>1</sup> /second major	6cp

**Spring semester**

91234	Uses of Australian Plants	6cp
	Electives <sup>1</sup> /second major	6cp

**Stages 5 and 6 – in 1998 and even years**

**Autumn semester**

91229	Horticultural Financial Management	4cp
91236	Plant Tissue Culture	4cp

*plus*

	Elective <sup>1</sup> /second major	4cp
--	-------------------------------------	-----

**Spring semester**

*either*

91271	Plant Genetics and Breeding	8cp
91224	Horticultural Production Management	4cp

*or*

91225	Open Space Management	4cp
	<i>plus</i>	
	Electives <sup>1</sup> /second major	8cp

**Stages 5 and 6 – in 1999 and odd years**

**Autumn semester**

91207	Plants in the Landscape	8cp
	Elective <sup>1</sup> /second major	4cp

**Spring semester**

*either*

91271	Plant Genetics and Breeding	8cp
91224	Horticultural Production Management	4cp

*or*

91225	Open Space Management	4cp
	<i>plus</i>	
	Electives <sup>1</sup> /second major	8cp

<sup>1</sup> For details of the electives available for the Environmental and Urban Horticulture degree, see Elective Options Table.

**Note:** The order in which part-time students undertake Stage 3, 4, 5 and 6 subjects is determined by the fact that subjects are offered in appropriate time slots in alternate years only. Students should note that excursions for field study elective subjects may be held in the weeks prior to semester and in other non-teaching weeks during the year.

## Elective Options Table for Environmental Biology and Environmental and Urban Horticulture Courses

Subject number	Subject name	Credit points	Semester A/S	Envir Biology	Urb Hort
91207	Plants in the Landscape	8	A	5	C
91233	Plant Production and Growth Media	6	A	5	C
91234	Uses of Australian Plants	6	S	6	C
91236	Plant Tissue Culture	4	A	5	C
91237	Plant Pathology	6	S	5	C
91270	Plant Physiology	6	A	C	C
91271	Plant Genetics and Breeding	8	S	6	C
91303	Experimental Design in Ecology	3	A	C	3
91306	Terrestrial Ecosystems	4	A	C	5
91307	Community and Population Ecology	3	S	C	4 or 6
91309	Australian Biota	6	S	C	4 or 6
91324	Environmental Toxicology	8	S	C	6
91313	Biochemistry 1	6	A	3 or 5	3 or 5
91314	Microbiology 1	6	A	3 or 5	3 or 5
91320	Biochemistry 2	6	S	6	4 or 6
91323	Mapping and Remote Sensing	4	A	5	5
91326	Analytical Biochemistry	6	S	6	4 or 6
91327	Environmental Management Procedures	4	S	6	6
91328	Environmental Microbiology	4	A	5	5
91329	Ecological Sampling	3	A	C	3 or 5
91330	Microbiology 2	6	S	C	6
91331	Microbiology 3	8	A	5	N/A
91332	Molecular Biology 1	8	A	5	N/A
91333	Introductory Marine Ecology	8	A & S	5 or 6	5 or 6
91335	Molecular Biology 2	8	S	6	N/A
91338	Clinical Bacteriology	8	S	N/A	N/A
91347	Toxic Materials in the Environment	4	S	6	6
91352	Eukaryotic Microbiology	8	S	6	N/A
91363	Animal Ecophysiology	6	S	C	6
91364	Aquatic Ecology	8	A	C	5
91370	Field Studies: Semi-Arid Ecology	8		5 or 6	5 or 6
91371	Field Studies: Mountain Ecology (Nov '98)	8	S	5 or 6	5 or 6
91375	Field Studies: Marine Sciences	4	A&S	5 or 6	5 or 6
91280	Current Urban and Environmental Issues A	4	A&S	5 or 6	5 or 6
91281	Current Urban and Environmental Issues B	6	A&S	5 or 6	5 or 6
91282	Current Urban and Environmental Issues C	8	A&S	5 or 6	5 or 6
91283	Undergraduate Research Project <sup>1</sup>	8	S	6	6
	Miscellaneous elective/LS elective (i.e. a subject from another faculty or university)	4/8	A&S	5 or 6	5 or 6

## Key:

A = Timetabled in Autumn semester

S = Timetabled in Spring semester

LS = Life Sciences

3/4/5/6 = Stage at which elective recommended

C = Core subject for that course

N/A = Not available to students in this degree

<sup>1</sup> Supervision form must be completed

**Notes:** Subjects recommended for particular stages can be undertaken by part-time students when programmable provided the prerequisites are met. Owing to timetabling constraints, not all electives may be available to all students in any given semester.

Students should note that excursions for field study elective subjects may be held in the weeks prior to semester and in other non-teaching weeks during the year.

## Bachelor of Science in Science Education

### Course code: N003

This course provides students with a degree in Science and a professional qualification in Education. The degree can be completed in four years, and comprises three-and-a-half years' full-time academic studies in science and education, and one-half year's industrial training in a scientific discipline.

The course is primarily a preparation for secondary school science teachers of chemistry, physics and geology. Graduates find employment in private and public secondary schools. However, the opportunity also exists for graduates to seek employment in the relevant scientific discipline. Their prospects of gaining such employment would be enhanced by undertaking a more extensive and rigorous industrial training program in science leading to the additional award of Diploma in Scientific Practice.

The degree is fully recognised by the NSW Department of School Education and by professional scientific bodies.

### Course program – Chemistry major

#### Year 1

##### Autumn semester

33190	Mathematical Modelling for Science	6cp
65101	Chemistry 1C	6cp
68101	Physics 1C	6cp
	<i>one of</i>	
66101	Earth Science 1	6cp
67101	Introduction to Materials	6cp
91311	Biology 1	6cp
91701	Medical Science 1	6cp

##### Spring semester

33290	Computing and Mathematics for Science	6cp
65201	Chemistry 2C	6cp
68201	Physics 2	6cp
	<i>one of</i>	
67101	Introduction to Materials	6cp
67303	Mechanical Properties of Materials	6cp
	<i>or</i>	
	Other approved subject	6cp

#### Year 2

##### Autumn semester

65202	Organic Chemistry 1	6cp
65306	Analytical Chemistry 1	6cp

65307	Physical Chemistry 1	6cp
	Science elective	6cp

##### Spring semester

65409	Analytical Chemistry 2	6cp
65411	Inorganic Chemistry 1	6cp
65410	Chemical Safety and Legislation	6cp
	Science elective	6cp

#### Year 3

##### Autumn semester

023001	Psychology of Secondary Students	3cp
023002	Meeting Special Needs in Secondary School	3cp
023191	Secondary Practicum 1	12cp
028001	Learning in Science 1	7cp

##### Spring semester

Professional/industrial Experience

#### Year 4

##### Autumn semester

Electives	24cp
-----------	------

##### Spring semester

023502	Social Bases of Education	4cp
023192	Secondary Practicum 2	12cp
028002	Learning in Science 2	7cp

### Course program – Physics major

#### Year 1

##### Autumn semester

33190	Mathematical Modelling for Science	6cp
65101	Chemistry 1C	6cp
68101	Physics 1C	6cp
	<i>one of</i>	
66101	Earth Science 1	6cp
91311	Biology 1	6cp
91701	Medical Science 1	6cp

##### Spring semester

33290	Computing and Mathematics for Science	6cp
65201	Chemistry 2C	6cp
67101	Introduction to Materials	6cp
68201	Physics 2	6cp

#### Year 2

##### Autumn semester

33390	Mathematics and Scientific Software	6cp
68314	Electronics	6cp
68311	Physics 3	6cp
68312	Applied Physics 1	6cp

##### Spring semester

33490	Computational Mathematics and Physics	6cp
-------	---------------------------------------	-----



## 76 UNDERGRADUATE COURSES

68411	Physics 4	6cp
68412	Applied Physics 2	6cp
	Science elective	6cp

### Year 3

#### Autumn semester

023001	Psychology of Secondary Students	3cp
023002	Meeting Special Needs in Secondary School	3cp
023191	Secondary Practicum 1	12cp
028001	Learning in Science 1	7cp

#### Spring semester

Professional/industrial experience

### Year 4

#### Autumn semester

Electives 24cp

#### Spring semester

023502	Social Bases of Education	4cp
023192	Secondary Practicum 2	12cp
028002	Learning in Science 2	7cp

## Course program – Earth Science major

### Year 1

#### Autumn semester

33101	Mathematics 1 (LS)	3cp
33106	Statistical Design and Analysis (2 sem)	3cp
66101	Earth Science 1	6cp
65012	Chemistry 1A	6cp
91311	Biology 1	6cp

#### Spring semester

33106	Statistical Design and Analysis (2 sem)	3cp
66204	Field Studies 1	6cp
65022	Chemistry 2A	6cp
91312	Biology 2	6cp
	<i>either</i>	
91395	Biocomputing	3cp
	<i>or</i>	
31871	Computing for Science	3cp

### Year 2

#### Autumn semester

66304	Earth Materials	6cp
66305	Fold Belts and Cratons	6cp
68041	Physics 1A	6cp
	Science elective	6cp

#### Spring semester

66408	Earth Resources	6cp
66407	Mapping and Remote Sensing	6cp
66409	Surficial Processes and Products	6cp
	Science elective	6cp

### Year 3

#### Autumn semester

023001	Psychology of Secondary Students	3cp
023002	Meeting Special Needs in Secondary School	3cp
023191	Secondary Practicum 1	12cp
028001	Learning in Science 1	7cp

#### Spring semester

Professional/industrial experience

### Year 4

#### Autumn semester

Electives 24cp

#### Spring semester

023502	Social Bases of Education	4cp
023192	Secondary Practicum 2	12cp
028002	Learning in Science 2	7cp

## Bachelor of Science/ Bachelor of Laws

### Course code: LL04

The BSc LLB degree course is aimed at producing graduates with professionally recognised qualifications in both science and law and who are well prepared to pursue a career in either field. Such graduates may choose to practice law in areas such as environmental law, patents and mining law where a strong background in science is of advantage. Alternatively they may choose to enter scientific careers, particularly as advisers, consultants or managers in industries where a knowledge of the law is of particular value.

Students completing the course are able to apply for admission as either solicitors or barristers of the Supreme Court of New South Wales.

The degree is a five-year full-time course and, subject to the fulfilment of the requirements described below, allows students to graduate with the separate degrees of Bachelor of Science and Bachelor of Laws. The study components and the requirements for course completion are as follows:

1. The law component comprises at least 144 credit points of study approved by the Faculty of Law.
2. The science component comprises at least 96 credit points of study approved by the Faculty of Science. For a student to be eligible for a separate Bachelor of Science

degree the science component must meet the additional criteria specified in (a) – (c) below:

- (a) the science component must be sufficiently focused to enable the student to command a coherent and integrated body of theoretical and practical knowledge in at least one field of science;
  - (b) within the total of 96 credit points, the value of science subjects that are normally offered in stages 1 and 2 of an undergraduate course of the Faculty of Science must not exceed 42 credit points; and
  - (c) within the total of 96 credit points, the value of science subjects that are normally offered in stages 5 and 6 of an undergraduate course of the Faculty of Science must be at least 24 credit points.
3. On completion of the science component as set out in 2(a) – 2(c) above a student who has also completed at least 96 credit points of law subjects approved by the Faculty of Law will be eligible for the award of Bachelor of Science.
  4. A student who qualifies for the award of Bachelor of Science according to 3 above will, on completion of the law component as approved by the Faculty of Law, be eligible for the award of Bachelor of Laws.
  5. A student who completes 144 credit points of study approved by the Faculty of Law and 96 credit points of study approved by the Faculty of Science but does not satisfy the conditions set out in 2(a) – 2(c) above will be eligible for the award of Bachelor of Science/Bachelor of Laws (single testamur).

The conditions specified above imply that students are normally expected to specialise in a particular area of science in order to obtain relevant professional recognition and to proceed to a separate science degree. The specialist areas currently available to students are applied chemistry, applied physics, materials science, earth science, biomedical science, biotechnology, environmental biology, environmental and urban horticulture. A guide as to which subjects may form an appropriate study program in each of these areas is given after the general program structure.

Students are required to have their science program approved by the relevant Head of Department prior to the commencement of semester. Certain study options could involve timetabling difficulties and students may need to be flexible in arranging their study programs.

### Course program

Each stage corresponds to one semester of full-time attendance.

#### Stage 1

##### Autumn semester

70113	Legal Process and History	10cp
70105	Legal Research	4cp
	Approved Science subjects	12cp

#### Stage 2

##### Spring semester

70217	Criminal Law	6cp
70211	Law of Contract	8cp
	Approved Science subjects	12cp

#### Stage 3

##### Autumn semester

70311	Law of Tort	8cp
70616	Federal Constitutional Law	8cp
	Approved Science subjects	6cp

#### Stage 4

##### Spring semester

70318	Personal Property	4cp
70317	Real Property	8cp
	Approved Science subjects	12cp

#### Stage 5

##### Autumn semester

70417	Corporate Law	8cp
70617	Administrative Law	8cp
	Approved Science subjects	6cp

#### Stage 6

##### Spring semester

70516	Equity and Trusts	8cp
76xxx	Elective Subject 1	6cp
	Approved Science subjects	12cp

#### Stage 7

##### Autumn semester

71216	Law of Evidence	6cp
71005	Practice and Procedure	4cp
	Approved Science subjects	12cp

## 78 UNDERGRADUATE COURSES

### Stage 8

#### Spring semester

71116	Remedies	6cp
76xxx	Elective Subject 2	6cp
	Approved Science subjects	12cp

### Stage 9

#### Autumn semester

76xxx	Elective Subject 3	6cp
76xxx	Elective Subject 4	6cp
	Approved Science subjects	12cp

### Stage 10

#### Spring semester

	Legal practice major (PLT)	24cp
	or	
	Four Law electives	24cp

Note: For descriptions of Law subjects please consult the 1998 Faculty of Law Handbook

## Recommended Science strands<sup>1,2</sup>

### Applied Chemistry (96 credit points)

65101	Chemistry 1C	6cp
68101	Physics 1C	6cp
65201	Chemistry 2C	6cp
68201	Physics 2	6cp
33190	Mathematical Modelling for Science	6cp
65410	Chemical Safety and Legislation	6cp
65411	Inorganic Chemistry 1	6cp
65306	Analytical Chemistry 1	6cp
65409	Analytical Chemistry 2	6cp
65202	Organic Chemistry 1	6cp
65307	Physical Chemistry 1	6cp
65606	Analytical Chemistry 3	6cp
65607	Physical Chemistry 2	6cp
65508	Organic Chemistry 2	6cp
65509	Inorganic Chemistry 2	6cp
	Science elective	6cp

### Applied Physics (96 credit points)

33190	Mathematical Modelling for Science	6cp
68101	Physics 1C	6cp
33290	Computing and Mathematics for Science	6cp
68201	Physics 2	6cp
33390	Mathematics and Scientific Software	6cp
68311	Physics 3	6cp
33490	Computational Mathematics and Physics	6cp
68411	Physics 4	6cp
68312	Applied Physics 1	6cp
68412	Applied Physics 2	6cp
68314	Electronics	6cp
68512	Applied Physics 3	6cp

68611	Electromagnetics and Optics	6cp
68511	Quantum and Solid State Physics	6cp
68514	Electronics and Interfacing Science elective	6cp

### Materials Science (96 credit points)

65101	Chemistry 1C	6cp
67101	Introduction to Materials	6cp
65201	Chemistry 2C	6cp
67303	Mechanical Properties of Materials	6cp
33190	Mathematical Modelling for Science	6cp
68101	Physics 1C	6cp
67305	Polymer Science	6cp
67506	Technical Ceramics	6cp
67407	Physical Properties of Materials	6cp
67408	Industrial Metallurgy	6cp
67304	Physical Metallurgy	6cp
67306	Industrial Ceramics	6cp
67608	Composites	6cp
67606	Corrosion and Degradation of Materials	6cp
67409	Polymer Technology	6cp
65062	Extractive Metallurgy	6cp

### Earth Science (96 credit points)

66101	Earth Science 1	6cp
65101	Chemistry 1C	6cp
66204	Field Studies 1	6cp
65201	Chemistry 2C	6cp
66304	Earth Materials	6cp
66407	Mapping and Remote Sensing	6cp
66408	Earth Resources	6cp
66305	Fold Belts and Cratons	6cp
66034	Groundwater Geology	4cp
66409	Surficial Processes and Products	6cp
66508	Crustal and Mantle Processes	6cp
66609	Environmental and Quaternary Geology	8cp
66610	Engineering Geology	4cp
66510	Geophysics	4cp
66509	Tectonics and Surface Dynamics Science electives	4cp
		12cp

### Biomedical Science (96 credit points)

91701	Medical Science 1	6cp
65101	Chemistry 1C	6cp
91702	Medical Science 2	6cp
65201	Chemistry 2C	6cp
91314	Microbiology 1	6cp
91330	Microbiology 2	6cp
91351	Immunology 1	3cp
91355	Haematology 1	3cp
91313	Biochemistry 1	6cp
91320	Biochemistry 2	6cp
91326	Analytical Biochemistry	6cp
91354	Anatomical Pathology	6cp
	Biomedical Science electives	24cp
	Science electives	6cp

**Biotechnology (96 credit points)**

91701	Medical Science 1	6cp
65101	Chemistry 1C	6cp
91702	Medical Science 2	6cp
65201	Chemistry 2C	6cp
91314	Microbiology 1	6cp
91325	Principles and Practice of Biotechnology	3cp
91330	Microbiology 2	6cp
91351	Immunology 1	3cp
91313	Biochemistry 1	6cp
91368	Bioprocessing	8cp
91326	Analytical Biochemistry	6cp
91332	Molecular Biology 1	8cp
91335	Molecular Biology 2	8cp
91369	Applied and Environmental Microbiology	8cp
	Science electives	10cp

**Environmental Biology (97 credit points)**

91311	Biology 1	6cp
65101	Chemistry 1C	6cp
91312	Biology 2	6cp
65201	Chemistry 2C	6cp
91329	Ecological Sampling	3cp
33106	Statistical Design and Analysis (2 sem)	6cp
91307	Community and Population Ecology	3cp
91308	Australian Soils	3cp
91395	Biocomputing	3cp
91270	Plant Physiology	6cp
91303	Experimental Design in Ecology	3cp
91309	Australian Biota	6cp
91363	Animal Ecophysiology	6cp
91306	Terrestrial Ecosystems	4cp
91318	Ecological Modelling	4cp
91324	Environmental Toxicology	8cp
91323	Mapping and Remote Sensing	4cp
91364	Aquatic Ecology	8cp
	Science electives	6cp

**Environmental and Urban Horticulture  
(97 credit points)**

91231	Horticulture 1	6cp
91311	Biology 1	6cp
91232	Horticulture 2	6cp
91312	Biology 2	6cp
91230	Landscape Design	3cp
91233	Plant Production and Growth Media	6cp
91234	Uses of Australian Plants	6cp
91308	Australian Soils	3cp
91395	Biocomputing	3cp
91236	Plant Tissue Culture	4cp
91270	Plant Physiology	6cp
91224	Horticultural Production Management	4cp
91237	Plant Pathology	6cp
91207	Plants in the Landscape	8cp
91225	Open Space Management	4cp

91271	Plant Genetics and Breeding	8cp
91229	Horticultural Financial Management	4cp
	Science electives	8cp

<sup>1</sup> These programs are indicative rather than prescriptive. Students may, with the approval of the Associate Dean or relevant Head of Department, undertake alternative programs in order to fulfil the academic requirements for the degree.

<sup>2</sup> The exact order in which the subjects are undertaken may vary depending upon timetable constraints and the number of science and law subjects each student elects to study in any one semester.

## Bachelor of Medical Science/Bachelor of Laws

**Course code: LL09**

This BMedSc LLB degree course is new in 1998 although students who commenced their BSc LLB degree (course code LL04) in 1997 and who elected to specialise in medical science may apply for transfer to the new course.

The course is aimed at producing graduates with recognised qualifications in both medical science and law and who are well prepared to pursue a career in either field. The law is of special importance in many areas of medical science including medical and health practice, medical research, and industrial and commercial enterprise. Hence, graduates could choose to practise in areas of law, such as certain types of litigation or criminal proceedings, where a strong scientific background in human biology, behavioural science, neuroscience, pharmacology, and medical devices and diagnostics, is particularly advantageous. Alternatively, they could practise as scientists in areas where a knowledge of the law is of particular advantage. Such areas could include pharmaceutical or biotechnology companies, or public health administration.

Students completing the course are able to apply for admission as either solicitors or barristers of the Supreme Court of New South Wales.

The degree is a five-year full-time course and allows students to graduate with the separate degrees of Bachelor of Medical Science and Bachelor of Laws. The first of these degrees may be awarded upon the completion of the specified 96 credit points of Medical Science subjects provided that the student has also completed 96 credit points of Law subjects approved by the Faculty of Law.

**Course program<sup>1</sup>****Stage 1****Autumn semester**

70113	Legal Process and History	10cp
70105	Legal Research	4cp
91701	Medical Science 1	6cp
65101	Chemistry 1C	6cp

**Stage 2****Spring semester**

70217	Criminal Law	6cp
70211	Law of Contract	8cp
91702	Medical Science 2	6cp
65201	Chemistry 2C	6cp

**Stage 3****Autumn semester**

70311	Law of Tort	8cp
70616	Federal Constitutional Law	8cp
68101	Physics 1C	6cp

**Stage 4****Spring semester**

70318	Personal Property	4cp
70317	Real Property	8cp
91704	Behavioural Sciences	6cp
68201	Physics 2	6cp

**Stage 5****Autumn semester**

70417	Corporate Law	8cp
70617	Administrative Law	8cp
91313	Biochemistry 1	6cp
91703	Physiological Systems	6cp

**Stage 6****Spring semester**

70516	Equity and Trusts	8cp
76xxx	Elective Subject 1	6cp
91708	Psychophysiology	8cp

**Stage 7****Autumn semester**

71216	Law of Evidence	6cp
71005	Practice and Procedure	4cp
91707	Pharmacology 1	8cp
	Approved Science elective	4cp

**Stage 8****Spring semester**

71116	Remedies	6cp
76xxx	Elective Subject 2	6cp
91709	Pharmacology 2	8cp
91705	Medical Devices and Diagnostics	6cp

**Stage 9****Autumn semester**

76xxx	Elective Subject 3	6cp
76xxx	Elective Subject 4	6cp
91706	Neuroscience	8cp

**Stage 10****Spring semester**

Legal practice major (PLT)	24cp
<i>or</i>	
Four Law electives	24cp

<sup>1</sup> The order in which the subjects are undertaken may vary depending upon timetable constraints and the number of Science and Law subjects each student elects to study in any one semester. Advice should be sought from the Associate Dean or the Head of the Department of Health Sciences.

Note: For descriptions of Law subjects please consult the 1998 Faculty of Law Handbook.

## Bachelor of Science/ Bachelor of Arts in International Studies

**Course code: N004**

The Faculty of Science, in collaboration with the Institute for International Studies, offers a combined degree program in Science and International Studies which is aimed at increasing students' awareness of international contexts and producing graduates who are well prepared for professional careers in science in an international setting.

The program is a five-year full-time course which links applied science studies with the study of a language and culture other than English, and the practice of science in other countries. It is available in association with the Bachelor of Science in the following fields:

- Applied Chemistry
- Applied Physics
- Biomedical Science
- Biotechnology
- Earth and Environmental Science
- Environmental and Urban Horticulture
- Environmental Biology
- Materials Science
- Medical Science

Arrangements may also be made for combining the International Studies program with the Bachelor of Science (Honours) in Applied Chemistry – Forensic Science though in this case the course length will be six years full time.

Details of all the above courses are given earlier in the Undergraduate Courses section of this handbook and it should be noted that students may also elect to undertake the professional/ industrial experience program leading to the additional award of Diploma in Scientific Practice. This will normally extend the length of the combined degree course by one year.

The International Studies component of the degree comprises 96 credit points and requires students to study a major – a region or country specialisation – over a minimum of three years. Language and culture studies are undertaken in Sydney for at least two years after which students spend a period of study overseas. The following range of majors are available: Argentina, Australia and the Asia-Pacific Region, Chile, China, Croatia, France, Germany, Greece, Indonesia, Italy, Japan, Latin America, Malaysia, Mexico, Poland, Russia, Slovenia, South China, South-East Asia, Spain, Taiwan, Thailand and Ukraine. In general, the International Studies program has no prior language requirement, except for entry to the Greece, Poland, Slovenia and Ukraine majors which is restricted to students who have a sound working knowledge of the language of their selected specialisation.

The Institute for International Studies makes arrangements for students to spend two semesters of In-country Study at an institution of higher education abroad. The costs of tuition overseas and travel to the designated overseas institution are borne by UTS, all other costs being borne by the individual student.

## Admission

Students are normally admitted directly to the first year of the course but there is provision for students already enrolled in a Bachelor of Science degree to transfer to the combined degree program. Applications for transfer are decided on the basis of academic merit and the preparedness of the student for undertaking International Studies.

Students admitted to the first year of the course may select any of the Science programs listed above provided that their entry rank is equal to or better than the cut-off for the chosen program.

## Course program<sup>1</sup>

The following general pattern will be followed for each Pass combined degree in Science and International Studies. A different pattern, extending over six years, would apply to a combined degree involving the Bachelor of

Science (Honours) in Applied Chemistry – Forensic Science, details of which will be worked out in consultation with the Head of the Department of Chemistry, Materials and Forensic Science.

### Year 1

#### Autumn semester

Stage 1 F/T Science program 24cp

#### Spring semester

Stage 2 F/T Science program 24cp

### Year 2

#### Autumn semester

Stage 3/4 P/T Science program 9 – 12cp

50140 Modernisation and Social Change 8cp

971xxx Language and Culture 1 8cp

#### Spring semester

Stage 3/4 P/T Science program 12 – 15cp

972xxx Language and Culture 2 8cp

### Year 3

#### Autumn semester

Stage 3/4 P/T Science program 12 – 15cp

973xxx Language and Culture 3 8cp

#### Spring semester

Stage 3/4 P/T Science program 9 – 12cp

974xxx Language and Culture 4 8cp

976xxx Contemporary Society 8cp

### Year 4

#### Autumn semester

977xxx In-country Study 1 24cp

#### Spring semester

978xxx In-country Study 2 24cp

### Year 5

#### Autumn semester

Stage 5 F/T Science program 24cp

#### Spring semester

Stage 6 F/T Science program 24cp

<sup>1</sup> The Bachelor of Medical Science and the Bachelor of Science (Honours) in Applied Chemistry – Forensic Science are offered only on a full-time basis and there is no specified part-time program. Students undertaking these options in combination with International Studies must consult with the relevant Head of Department to determine their academic program in the second and third year of the combined degree.

**Note:** For descriptions of International Studies subjects please consult the 1998 *Institute for International Studies Handbook*.

## SECOND MAJORS

Students enrolled in a Bachelor of Science or Bachelor of Medical Science degree in the Faculty of Science are normally expected to undertake a second major as part of their course. Each second major comprises a coherent sequence of subjects offered by the Faculty of Science, another faculty of the University, or the Institute for International Studies. The purpose of the second major is to give students the opportunity to broaden their studies into other areas of interest or to pursue studies in particular disciplines to greater depth.

Examples of possible second majors are listed below but it should be noted that not all of them are necessarily appropriate to every course and that normal prerequisite conditions apply in all cases.

### Faculty of Science

#### Environmental Biology

91311	Biology 1	6cp
91312	Biology 2	6cp
91303	Experimental Design in Ecology	3cp
91329	Ecological Sampling	3cp
91307	Community and Population Ecology	3cp
91327	Environmental Management Procedures	4cp

#### Earth Science

66101	Earth Science 1	6cp
66204	Field Studies 1	6cp
66304	Earth Materials	6cp
	<i>plus one or more of the following to a total of not less than 24cp</i>	
66409	Surficial Processes and Products	6cp
66610	Engineering Geology	4cp
66034	Groundwater Geology	4cp
66609	Environmental and Quaternary Geology	8cp
66408	Earth Resources	6cp
66407	Mapping and Remote Sensing	6cp
66510	Geophysics	4cp
	(New geochemistry/organic geochemistry elective for SUCOGG)	4cp

#### Chemistry for non-Chemistry majors

65306	Analytical Chemistry 1	6cp
65409	Analytical Chemistry 2	6cp
65202	Organic Chemistry 1	6cp
65508	Organic Chemistry 2	6cp

### Applied Chemistry for Chemistry majors

*at least four of the following*

65xxx	Applied Organic Chemistry (Pharmaceutical and Medicinal)	6cp
65xxx	Chemical Process Control	6cp
67606	Corrosion and Degradation of Materials	6cp
65xxx	Environmental Chemistry	6cp
65062	Extractive Metallurgy	6cp

### Medical Science

91701	Medical Science 1	6cp
91702	Medical Science 2	6cp
	<i>plus at least two of</i>	
91313	Biochemistry 1	6cp
91314	Microbiology 1	6cp
91703	Physiological Systems	6cp
91704	Behavioural Sciences	6cp
91705	Medical Devices and Diagnostics	6cp

### Faculty of Mathematical and Computing Sciences

#### Statistics

This second major is suitable for students in Biological and Medical Science programs.

35254	Health Statistics	6cp
35252	Statistics 2	6cp
35353	Regression Analysis	6cp
35356	Design and Analysis of Experiments	6cp

This second major is suitable for students in physical science programs.

35151	Statistics 1	6cp
35252	Statistics 2	6cp
35353	Regression Analysis	6cp
35356	Design and Analysis of Experiments	6cp

#### Mathematics

This second major is suitable for students in physical science programs.

35212	Linear Algebra	6cp
35231	Differential Equations	6cp
35241	Optimisation 1	6cp
35281	Numerical Analysis 1	6cp

**Faculty of Engineering and/or Faculty of Mathematical and Computing Sciences**

**Computing and Computer Systems**

An individually designed second major in computing and/or computer systems for students in Applied Physics programs can be arranged in consultation with the Course Coordinator and, where necessary, appropriate staff from the Faculty of Engineering or the Faculty of Mathematical and Computing Sciences. These subjects are normally taken after completing the core computing subjects taken by all applied physics students.

**Example 1**

48440	Software Development 2	6cp
48450	Operating Systems	6cp
48451	Digital Systems	6cp
48570	Data Acquisition and Distribution	6cp

**Example 2**

*at least 24 credit points from the following*

31415	Principles of Software Development A	6cp
31425	Principles of Software Development B	6cp
31426	Systems Software and Networks	6cp
31428	Quantitative Modelling	6cp
31429	Procedural Programming	6cp
31748	Programming on the Internet	4cp
31904	Systems Programming	4cp

**Faculty of Business**

**Management Practice**

This second major is designed for students who wish to gain knowledge of the management process, including management and communication skills, employment relations practice, management of business processes and managing the strategy process.

21440	Management Skills	6cp
21306	International Employment Relations	6cp
21131	Business Process Management	6cp
21630	Managing the Strategy Process	6cp

**Small and Medium Enterprise Management**

This second major prepares students for a management role in the small and medium enterprise business sector by providing an understanding of the peculiarities of small and new businesses, which differentiate them from large corporations and government

enterprises. This second major is offered at the City campus on demand and partially at the Kuring-gai campus on demand.

21131	Business Process Management	6cp
21409	Entrepreneurship and Innovation	6cp
21082	Small and Medium Enterprise Management	6cp
22566	Accounting for Small Business 1	6cp

**Leisure Management**

This second major provides an understanding of the role of leisure in contemporary society, focusing on the management and marketing of leisure services. This second major is offered at the Kuring-gai campus only.

27126	Leisure in Australia	6cp
27216	Leisure Services Management	6cp
27523	Leisure and Tourism Planning	6cp
<i>plus one of the following</i>		
27628	Law for Leisure, Sport and Tourism	6cp
27306	Marketing of Leisure Services	6cp
27179	Festivals and Special Events	6cp
27316	Leisure and Fitness Centre Operations	6cp

**Tourism Management**

This second major provides students with a systematic framework for understanding the tourism phenomenon in Australia. This second major is offered at the Kuring-gai campus only.

27184	Introduction to Tourism Systems	6cp
27648	The Tourism Industry	6cp
27706	Tourism Management	6cp
<i>plus one of the following</i>		
27628	Law for Leisure, Sport and Tourism	6cp
27185	Introduction to Tourist Behaviour	6cp
27642	Tourism Services Marketing	6cp
27523	Leisure and Tourism Planning	6cp

**Faculty of Nursing**

**Health Services Management**

This second major is designed to provide skills, knowledge and understanding of management as it relates to health services and settings. This second major is offered at the Kuring-gai campus only.

92112	Health Care in Australia	6cp
92113	Trends in Health Care	6cp
92114	Health Services Management	6cp
92115	Planning and Evaluating Health Services	6cp



**Faculty of Humanities and Social Sciences/Faculty of Education**

**Aboriginal Studies**

015110	Aboriginal Culture and Philosophies	8cp
52220	Aboriginal Social and Political History	8cp
52239	Aboriginal People and the Media	8cp

**Faculty of Humanities and Social Sciences**

**Communication and Information**

*at least three of the following*

50105	Communication and Information Environments	6cp
50106	Media, Information and Society	6cp
50125	Communication and Audience	8cp
50126	Information and the Organisation	8cp
50127	International Communication	8cp
50130	Organisation Change and Communication	8cp

**Information**

*at least three of the following*

50112	Information in Society	6cp
50113	Information Resources	6cp
50143	Research Methods and Data Analysis	8cp
50144	Organising and Retrieving Information	8cp
50146	Internet and Electronic Information Networking	8cp
50147	Creating User Documentation	8cp

**Public Communication**

*at least three of the following*

50118	Public Communication Processes	6cp
50119	Public Communication Challenges	6cp
50519	Public Relations Principles	8cp
50610	Public Relations Strategies	8cp
50161	Advertising Production and Criticism	8cp
50162	Advertising Communication Strategies	8cp

**Faculty of Education**

Second majors are available through the Faculty of Education in the following areas:

- Art
- Educational Computing
- Education
- English
- History
- Music
- Personal Development, Health and Physical Education

For further information please contact Associate Professor M Cosgrove, Faculty of Education, telephone 9514 5282, fax 9514 5556.

# Postgraduate courses

## General Information

The Faculty offers both PhD and Master's programs by research and thesis. There are also a number of Master's by coursework, Graduate Diploma and Graduate Certificate programs. Brief outlines of the programs are provided below. Prospective students should discuss possible topics of research with the Head of the appropriate department in the first instance. For further formal information, they should consult the University Graduate School information booklet and individual brochures.

## External supervision

The research programs may be carried out on either a full-time or a part-time basis, and it is permissible for part-time students to undertake a portion of their research at a site external to UTS, provided an appropriate external supervisor can be appointed. Students applying for the part-time study mode with external supervision are required to show, prior to enrolment, that appropriate supervision, research support and facilities are available. These requirements are in addition to the normal requirement of internal supervision of an agreed research topic.

## Fees and Higher Education Contribution Scheme

Higher Education Contribution Scheme (HECS) will normally apply to all Research and Master's by coursework students. Course fees apply for all Graduate Certificates. At the discretion of the Vice-Chancellor, HECS scholarships have, in recent years, been granted to students enrolled in Doctoral degrees. All enrolled students are required to pay the compulsory University Union and Students' Association charges on enrolment.

## Postgraduate scholarships

A number of scholarships are available to postgraduate students undertaking Master's and Doctoral programs both by coursework and research. The Department of Employment, Education, Training and Youth Affairs (DEETYA) currently funds research, coursework and overseas research postgraduate awards. Information regarding eligibility criteria and how to apply for these scholarships is available from the University

Graduate School, City campus of UTS. Closing dates for these scholarships have, in recent years, been in late September/October of the year prior to award.

## GRADUATE CERTIFICATE COURSES

### Graduate Certificates in Clinical Biochemistry

Graduate Certificate in Biochemical Analysis (KB81)

Graduate Certificate in Clinical Biochemistry (KB79)

Graduate Certificate in Medical Biochemistry (KB82)

### Graduate Certificates in Coastal Resource Management (KB69)<sup>1</sup>

### Graduate Certificates in Ecotoxicology<sup>2</sup>

Field Methods in Ecotoxicology (KB84)

Laboratory Methods in Ecotoxicology (KB83)

Management in Ecotoxicology (KB85)

Principles of Ecotoxicology (KB77)

### Graduate Certificate in Environmental Engineering and Management<sup>1</sup> (EC58)

### Graduate Certificates in Medical Microbiology

Graduate Certificate in Diagnostic Bacteriology (KB88)

Graduate Certificate in Medical Microbiology (KB86)

Graduate Certificate in Molecular Microbiology (KB87)

Graduate Certificate in Parasitology and Mycology (KB89)

### Graduate Certificates in Occupational Health and Safety

Occupational Health and Safety (P053)

Occupational Health and Safety Management (P054)

<sup>1</sup> Interdisciplinary course run by the Faculty of Science in collaboration with the Faculties of Engineering; Business; Law; and Design, Architecture and Building. Modified Programs will be offered subject to University approval.

<sup>2</sup> In collaboration with the NSW Environment Protection Authority.

## Attendance

The Graduate Certificate courses in Coastal Resource Management, Ecotoxicology, Medical Microbiology and Clinical Biochemistry normally consist of two or three subjects offered over one semester for up to nine hours per week. The Graduate Certificate course in Environmental Engineering and Management is normally offered over two semesters. Offered at the postgraduate level, these courses allow professionals to undertake a specific group of work-related subjects in order to enhance their knowledge in the rapidly expanding fields of science and technology.

## Course fees

Course fees will apply for all Graduate Certificate courses. Postgraduate students are also required to pay the student services charge on enrolment. The Graduate Certificate fee-paying courses are designed for students who do not wish to undertake a Master's degree and/or have been unable to gain entry into the Master's degree program. Students who have completed a Graduate Certificate and have achieved a high level of academic performance in the course may apply for entry to an appropriate Master's degree program. Such applications will be considered subject to vacancies.

## Graduate Certificates in Clinical Biochemistry

There are three graduate certificates in clinical biochemistry. They are: Graduate Certificate in Clinical Biochemistry, Graduate Certificate in Biochemical Analysis and Graduate Certificate in Medical Biochemistry. Each of these is to be completed as one semester of formal coursework.

## Admission requirements

Admission to these courses is open to science graduates of approved tertiary institutions where biochemistry has been a significant component of the degree, or persons with equivalent qualifications. Key computing skills are also a requirement. Places will be offered on academic merit.

All academic inquiries are to be directed to the Course Coordinator in Clinical Biochemistry, Dr Ralph Orwell, Department of Cell and Molecular Biology, telephone (02) 9514 4098; fax (02) 9514 4003.

## Graduate Certificate in Clinical Biochemistry

**Course code: KB79**

**Available in Autumn semester**

91410	Principles of Clinical Biochemistry	8cp
91417	Clinical Laboratory Management	4cp

## Graduate Certificate in Biochemical Analysis

**Course code: KB81**

**Available in Autumn semester**

91426	Analytical Techniques in Clinical Biochemistry	8cp
91474	Statistics in Bioscience	4cp

## Graduate Certificate in Medical Biochemistry

**Course code: KB82**

**Available in Spring semester**

91411	Biochemical Pathophysiology	8cp
91467	Clinical Biochemistry Advanced Aspects	8cp

## Graduate Certificate in Coastal Resource Management

**Course code: KB69**

This course is designed to introduce graduates to general concepts and technical and scientific aspects of coastal resource management. The course would be particularly suitable for graduates without a scientific background in their undergraduate degree course e.g. graduates from business or law courses. Science graduates may also be interested to extend their range of expertise, in the context of coastal resource management.

This Graduate Certificate course comprises 12 credit points of part-time study. The subjects undertaken by individual candidates will be drawn from those offered in the Master's program, the combination of subjects being determined by a candidate's needs and academic background.

## Graduate Certificates in Ecotoxicology

There are four graduate certificates in ecotoxicology, with two in each semester, that are designed to provide training in specific areas of ecotoxicology. They are: Graduate Certificate in Principles of Ecotoxicology, Graduate Certificate in Laboratory Methods in Ecotoxicology, Graduate Certificate in Field Methods in Ecotoxicology, and Graduate Certificate in Management in Ecotoxicology. Each of these is to be completed as one semester of formal coursework, with a student load of 12 credit points per semester. Most classes are conducted at the St Leonards campus.

### Admission requirements

Admission to these courses is open to graduates with degrees in biological sciences, chemistry, agriculture, pharmacy, engineering or equivalent disciplines. Computing skills in the use of word processing, spreadsheet, simple graphics, email, and accessing the Internet, are required for submission of assignments and reports. English language levels are as required by the University.

All academic inquiries are to be directed to the Course Coordinator in Ecotoxicology, Ms Alex Pulkownik, Department of Environmental Sciences Room GH 1.19B, telephone (02) 9514 4035; fax (02) 9514 4003 email a.pulkownik@uts.edu.au

## Graduate Certificate in Principles of Ecotoxicology

### Course code: KB77

This Graduate Certificate course is an introductory course in ecotoxicology that deals with the sources, chemistry and effects of toxic substances on the biota and the use of bioassay as a means of assessing their toxicity.

#### Available in Autumn semester

91468	Introduction to Ecotoxicology <i>and either</i>	8cp
91493	Biosystems <i>or</i>	4cp
91474	Statistics in Bioscience	4cp

## Graduate Certificate in Laboratory Methods in Ecotoxicology

### Course code: KB83

This Graduate Certificate is designed to acquaint the student with the variety of laboratory-based methods used to assess the biochemical and physiological responses in plants and animals to the entry, transformation and removal of toxic substances in plants and animals.

#### Available in Autumn semester

91469	Laboratory Methods in Ecotoxicology	12cp
-------	-------------------------------------	------

## Graduate Certificate in Field Methods in Ecotoxicology

### Course code: KB84

This Graduate Certificate is designed to introduce the students to the field investigation methodology used in ecotoxicology and to the elements of appropriate experimental design and analysis.

#### Available in Spring semester

91470	Field Methods in Ecotoxicology	8cp
91440	Experimental Design and Methods	4cp

## Graduate Certificate in Management in Ecotoxicology

### Course code: KB85

This Graduate Certificate is designed to provide the students with an understanding of the principles underlying environmental assessment and management, and of the application of ecotoxicology to long term environmental management in general.

#### Available in Spring semester

91494	Ecosystem Assessment	6cp
91495	Environmental Risk Assessment and Management	6cp

## Graduate Certificate in Environmental Engineering and Management

**Course code: EC58**

Environmental engineering and management are high on the political agenda. They also have a high professional priority. The Code of Ethics of the Institution of Engineers, Australia reminds its members that their responsibility '... for the welfare, health and safety of the community shall at all times come before their responsibility to the profession, to sectional or private interest or to other Engineers'. This responsibility applies equally to scientists, town planners and other professionals working in this field. They have a compelling duty to ensure that the adverse effects of development on the total environment are minimised.

This course of four subjects deals with the broad aspects of environmental management relevant to practising professionals in engineering, science, planning, architecture, law, surveying, health and building. Completing the course will develop a background and competency in environmental management.

More specifically, it will develop an awareness of ecological process; a sensitivity to the possible impacts of planned actions on environment; an understanding of the issues related to monitoring and to reducing the impacts of those actions; and professional skills to work as part of an integrated team responsible for environmental planning and management.

### Duration of course and attendance patterns

This course is offered on a block-release pattern of study. The normal attendance pattern is based on two subjects per semester requiring a minimum of two semesters to complete the course.

### Admission requirements

The normal educational qualification for admission is a Bachelor's degree in engineering, science, design, architecture, building, surveying or planning. Equivalent qualifications will be considered on their merits.

Provisional admission for graduates from disciplines other than those above will be available provided their education contained an adequate introduction to mathematics and physical sciences. Each application in these categories will be used as a selection criterion if acceptable applications outnumber available places.

### Articulation with Master's program

Work undertaken under this Graduate Certificate enrolment may be credited towards a Master's degree provided the requirements of the Master's degree are met in full, in terms of subject coverage and project weighting. However, completion of the requirements for the Graduate Certificate in Environmental Engineering and Management does not guarantee acceptance for Master's candidature.

### Course structure

#### Semester 1

49121	Environmental Assessment and Planning	6cp
49122	Environmental Engineering and Management Practices	6cp

#### Semester 2

49123	Industrial Waste Minimisation	6cp
49124	Water Quality Management	6cp

Academic inquiries should be directed to the following persons:

Associate Professor R Buckney,  
Associate Dean (Coursework Programs),  
Faculty of Science, Room GH2.3a,  
telephone (02) 9514 4096;

Dr M Dawson, Department of Chemistry,  
Materials and Forensic Science, Room 4/208,  
telephone (02) 9514 1717;

Professor S Vigneswaran, Faculty of  
Engineering, Room 2/523,  
telephone (02) 9514 2641;

Dr J Broadbent, Faculty of Design,  
Architecture and Building, Room 6/610,  
telephone (02) 9514 8986.

## Graduate Certificates in Medical Microbiology

There are four graduate certificates in medical microbiology, with two in each semester. They are: Graduate Certificate in Medical Microbiology, Graduate Certificate in Molecular Microbiology, Graduate Certificate in Diagnostic Bacteriology, and Graduate Certificate in Parasitology and Mycology. Each of these is to be completed as one semester of formal coursework.

### Admission requirements

Admission to these courses is open to science graduates of approved tertiary institutions where microbiology has been a significant component of the degree, or persons with equivalent qualifications. Key computing skills are also a requirement. Places will be offered on the basis of academic merit. Employment experience in a microbiology laboratory is advantageous, but not mandatory.

All academic inquiries are to be directed to the Course Coordinator in Medical Microbiology, Dr Iain Stevenson, Department of Cell and Molecular Biology, telephone (02) 9514 4154; fax (02) 9514 4003 email Iain.Stevenson@uts.edu.au

## Graduate Certificate in Medical Microbiology

**Course code: KB86**

---

### Available in Autumn semester

91480	Epidemiology and Disease Control	6cp
91417	Clinical Laboratory Management	4cp

## Graduate Certificate in Molecular Microbiology

**Course code: KB87**

---

### Available in Autumn semester

91417	Clinical Laboratory Management	4cp
91488	Molecular Microbiology	8cp

## Graduate Certificate in Diagnostic Bacteriology

**Course code: KB88**

---

### Available in Spring semester

91454	Diagnostic Bacteriology	8cp
91481	Current Topics in Clinical Microbiology	4cp

## Graduate Certificate in Parasitology and Mycology

**Course code: KB89**

---

### Available in Spring semester

91455	Human Parasitology and Mycology	8cp
91481	Current Topics in Clinical Microbiology	4cp

## Graduate Certificate in Occupational Health and Safety

**Course code: P053**

---

This program involves an appropriate selection of subjects from those offered in the Master's program.

For information contact the Course Coordinator, Dr Deirdre Cobbin, Department of Health Sciences, telephone (02) 9514 2231.

## Graduate Certificate in Occupational Health and Safety Management

**Course code: P054**

---

This program involves an appropriate selection of subjects from those offered in the Master's program. For information contact the Course Coordinator, Dr Deirdre Cobbin, Department of Health Sciences, telephone (02) 9514 2231.

## GRADUATE DIPLOMA COURSES

The Faculty offers a Graduate Diploma in Hydrogeology and Groundwater Management (N061) and a Graduate Diploma in Occupational Health and Safety (P052).

For Graduate Diploma courses, exemptions from subjects may be granted if a student can provide documented evidence of completed formal tertiary studies or recognised prior learning in the area. Exemptions will be granted at the discretion of the relevant Course Coordinator who will make a recommendation to the Faculty of Science Graduate Courses Committee. Total exemptions will not exceed a maximum of 50 per cent of the total credit points of the program. Exemptions may be granted for subjects previously completed at the undergraduate and postgraduate level, but the maximum exemptions granted for undergraduate subjects will not exceed 25 per cent of the total credit points of the program.

### Requirements for student progression

Students enrolled in a Graduate Diploma who fail in any two subjects, or any one subject twice, will be seen as making unsatisfactory progress and will have their registration discontinued. Students may appeal against such discontinuation of registration under Rule 3.2.7 (see the UTS *Postgraduate Student Handbook*).

## Graduate Diploma in Hydrogeology and Groundwater Management

**Course code: N061**

This course is designed for students working in the area of groundwater resource management.

### Admission requirements

Applicants should hold a four-year science degree from UTS or an equivalent qualification. Non-science graduates may be admitted to this course if their qualifications are relevant to hydrogeology and groundwater management. Applicants with other qualifications relevant to groundwater resource development may be accepted for admission, subject to approval by the Faculty Board.

### Attendance

The course is offered on a block-release attendance pattern and students may extend their enrolment over more than one year.

### Duration

The course requires block-release attendance of three periods of one day each during the Autumn semester. It has a pattern similar to the Master of Science in Hydrogeology and Groundwater Management. However, the project work of the Spring semester is shorter and requires completion by the end of the teaching semester. This course is also available in Distance Mode and has a similar residential component to the Master of Science in Hydrogeology and Groundwater Management.

### Course structure

With the exception of Project (12 credit points) and Computing for Groundwater Specialists, all subjects have a credit point value of six.

#### Autumn semester

- 66014 Hydrogeology
- 49550 Computing for Groundwater Specialists<sup>1</sup>
- 49555 Groundwater Modelling
- 66015 Hydrogeochemistry
- 49551 Surface Hydrology and Groundwater
- Elective 1
- Elective 2

**Spring semester**

- 66022 Groundwater Science Project (GD) F/T  
or  
66024 Groundwater Science Project (GD) P/T

**Electives**

- 49554 Groundwater Computing  
66016 Geophysics and Remote Sensing of  
Groundwater Resources  
66017 Geopollution Management  
66018 Groundwater Geophysics  
66025 Contaminated Site Management  
An approved subject offered elsewhere

<sup>1</sup> This is a non-credit subject available to students whose computing background requires strengthening.

## Graduate Diploma in Occupational Health and Safety

**Course code: P052**

*Course coordinator: Dr D Cobbin*

The aim of the course is to provide a graduate program in occupational health and safety which will produce broadly based, practical occupational health and safety professionals, with the ability to promote and facilitate a preventive approach to occupational health and safety which minimises occupational injuries and diseases.

**Objectives**

The behavioural objectives of the course are to enable graduates of the Master of Occupational Health and Safety to:

- influence managers so that occupational health and safety becomes an integral part of day-to-day management;
- manage occupational health and safety services within the context of legislative, regulatory and industrial relations environments;
- recommend practical and appropriate solutions to occupational health and safety problems;
- contribute to improvements in design of plant, processes and equipment, work practices, work organisation and environment, including access for people with disabilities;
- apply their knowledge of the concepts of occupational health and safety to satisfy the needs of people;

- be able to establish systems to recognise, evaluate and control hazards;
- disseminate information and increase awareness of occupational health and safety issues in the workplace;
- understand minimum requirements in order to interpret the intent of legislation and standards;
- collect, analyse and maintain relevant data;
- operate as a sole operator and as a member of a multidisciplinary team;
- coordinate/liase with relevant bodies in occupational health and safety;
- be involved with the rehabilitation of injured workers and the deployment of people with disabilities;
- recognise their own limitations and be aware of and call on other experts when needed;
- recognise the need, and be able, to maintain the currency of their knowledge.

**Duration**

In general the course is offered on a part-time basis over two years, and will require attendance at the University's City campus, Broadway, for eight hours per week. Students will be expected to satisfactorily complete 12 credit points per semester. The subjects will generally be scheduled so that students will attend for four hours on two evenings per week. Depending on availability of subjects it may be possible to complete the course in one year on a full-time basis.

**Admission requirements**

Students in this course could come from a wide variety of educational backgrounds, including the physical sciences, life sciences, health sciences, social science, medicine, engineering, industrial design, architecture, building, commerce, business, law and the humanities. Applicants will in general be required to have a degree in their discipline from a recognised university or college of advanced education in order to satisfy the basic admission requirement.

In this field, however, there are many very experienced people such as occupational health nurses, safety officers and inspectors who for historical reasons do not have a first degree. Applicants in this category are also encouraged to apply. Such applicants would be required to have at least a diploma or



certificate in a relevant area together with sound experience in occupational health and safety in a responsible position.

### Course structure

The course has been structured to provide the required basic knowledge and skills for students with different backgrounds. Subjects available in 1998 are as follows:

#### Autumn semester

69312	Occupational Hazard Analysis	6cp
69325	Data Analysis in Occupational Health and Safety	3cp
69332	Chemical Safety (OHS)	3cp
69336	Evaluating OHS (Construction Industry)	6cp
69343	Occupational Health and Safety Management	3cp

#### Spring semester

69313	Organisational Behaviour and Communication	3cp
69323	Human Factors/Ergonomic Design	3cp
69334	Occupational Health Services	3cp
69335	People and the Physical Environment	3cp
69341	Risk Management	6cp

For further information contact the Course Coordinator, Occupational Health and Safety, Dr D Cobbin, telephone (02) 9514 2231, fax (02) 9514 2228, email Deidre.Cobbin@uts.edu.au

## MASTER'S DEGREES (BY COURSEWORK)

Master of Coastal Resource Management <sup>1</sup>	KB59
Master of Health Science in Traditional Chinese Medicine	NH61
Master of Occupational Health and Safety	P055
Master of Science in Clinical Biochemistry	KB55
Master of Science (Honours) in Clinical Biochemistry	KB61
Master of Science in Ecotoxicology <sup>2</sup>	KB52
Master of Science (Honours) in Ecotoxicology	KB62
Master of Science in Hydrogeology and Groundwater Management	N057
Master of Science in Medical Microbiology	KB57
Master of Science (Honours) in Medical Microbiology	KB60

<sup>1</sup> Interdisciplinary course run by the Faculty of Science in collaboration with the Faculties of Engineering, Business, Law, and Design, Architecture and Building.

<sup>2</sup> In collaboration with the NSW Environment Protection Authority.

### Admission requirements and selection

Candidates may be admitted to the course with either a Bachelor's degree from UTS (or equivalent) or such other general or professional qualifications as will satisfy the Academic Board that the applicant possesses the educational preparation and capacity.

### Requirements for subject assessment and student progression

Students enrolled for a Master's degree (by coursework) shall have each subject assessed according to the normal Rules of this University. However, there is no allowance for conceded pass.

Students who fail in any two subjects, or any one subject twice, will be seen as making unsatisfactory progress and will have their registration discontinued. Students may appeal against such discontinuation of registration under Rule 3.3.8 (see the UTS *Postgraduate Student Handbook*).

### Continuing UTS students

Master's degree (by coursework) students who have previously been enrolled in undergraduate UTS courses in the Faculty may not enrol in postgraduate subjects which are equivalent to subjects previously undertaken towards an undergraduate degree.

# Master of Coastal Resource Management

**Course code: KB59**

*Course coordinator:*

*Associate Professor K R Brown*

The degree in Coastal Resource Management is a joint enterprise of the Faculties of Science, Engineering and Business, in collaboration with the Faculties of Law, and Design, Architecture and Building.

## Objectives

The course is part of the UTS Coastal Resource Management program, the aims of which are to:

- offer interdisciplinary professional courses for work in industry and government;
- conduct the research needed to improve the management of coastal resources;
- collaborate with industry and government in identifying areas of concern;
- provide consultancy and information resources to industry and government;
- help provide effective solutions to the complex problems of this area of study;
- enhance community awareness and education in this area; and
- develop a centre of expertise in the Pacific region.

The course will enable graduates to enter or develop a career in coastal resource management in commerce, industry, consultancy, or with government agencies, as one of the new generation of environmental managers with:

- an understanding of coastal processes;
- an ability to assess the possible impacts of planned actions on coastal and marine environments;
- a willingness and ability to monitor and reduce the impacts of those actions;
- the professional skills to work in integrated teams for environmental problem solving, planning and management; and
- an ability to manage coastal resources in developing and developed environments.

The course includes field work, site inspections, laboratory procedures and a variety of desk studies. The course equips environmental managers who, as part of a

team, can take responsibility for decision making and conflict resolution with respect to coastal resources.

## Duration

The course can be completed over two years of part-time study, normally involving attendance on one afternoon and two evenings each week. Associated short courses, based on the various subject modules, and a one-year full-time option for the Master's course are available.

## Admission requirements

Admission to the course is open to graduates in science, engineering, architecture, building, business, law, or equivalent background. Applicants with general or professional qualifications which satisfy the Academic Board of capacity to pursue graduate studies may also qualify for admission. Entrants may be eligible for exemptions from one or more of the foundation subjects, on the basis of prior qualifications.

Linkages with other programs nationally and internationally further provide the opportunity for graduates to expand their professional exposure.

## Full-time program

(Including Summer and Winter teaching periods)

### Autumn semester

98702	Coastal Ecosystems	4cp
98704	Biotic Resources	4cp
98707	Topics in Coastal Management (2 sem)	2cp
98709	Urban Stormwater Management	6cp
98711	Coastal Resource Policy	6cp
98716	Geological Resources	4cp
98718	Pollution Assessment	4cp

### Spring semester

91478	Economics of Coastal Resources	4cp
91479	Coastal Zone Law	4cp
98703	Public Administration and Management	4cp
98705	GIS and Resources Assessment	4cp
98706	Coastal Planning	4cp
98707	Topics in Coastal Management (2 sem)	2cp
98708	Risk Assessment and Management	6cp
98713	Coastal Processes	6cp
98719	Recreation, Tourism and Natural Resource Management	4cp

**Part-time program****Stage 1****Autumn semester**

98702	Coastal Ecosystems	4cp
98704	Biotic Resources	4cp
98711	Coastal Resource Policy	6cp
98716	Geological Resources	4cp

**Spring semester**

91478	Economics of Coastal Resources	4cp
91479	Coastal Zone Law	4cp
98705	GIS and Resources Assessment	4cp
98713	Coastal Processes	6cp

**Stage 2****Autumn semester**

98707	Topics in Coastal Management (2 sem)	2cp
98709	Urban Stormwater Management	6cp
98718	Pollution Assessment	4cp

**Spring semester**

98703	Public Administration and Management	4cp
98706	Coastal Planning	4cp
98707	Topics in Coastal Management (2 sem)	2cp
98708	Risk Assessment and Management	4cp
98719	Recreation, Tourism and Natural Resource Management	4cp

**Note:** Students who, on the basis of their prior learning, qualify for exemption from one or more subjects may be required to undertake other subjects of equal value. Recommended substitute subjects are:

17205	Project Management Studies	
17516	Environment and Infrastructure 1	4cp
17522	Environment and Infrastructure 2	4cp
21720	Employment Relations	6cp
21722	Leadership and Management	6cp
21724	Human Resource Management	6cp
21766	Managing Community Organisations	6cp
21767	Environment of Community Organisations	
27714	Tourism Attractions Management	6cp
49124	Water Quality Management	6cp
49126	Land Resource and Environmental Management	6cp
49452	Environmental Management	6cp
59337	Sociology and Planning	2cp
59336	Politics and Planning	2cp
66017	Geopollution Management	5cp
66025	Contaminated Site Management	5cp
91472	Field Surveillance, Fate and Management of Toxic Substances	12cp

For further information contact the Course Coordinator, Coastal Resource Management, Associate Professor K R Brown, telephone (02) 9514 4042/4393, fax (02) 9514 4079, email [Kenneth.Brown@uts.edu.au](mailto:Kenneth.Brown@uts.edu.au)

**Master of Health Science in Traditional Chinese Medicine****Course code: NH61**

*Course coordinator:* Associate Professor C Rogers  
Subject to approval by Academic Board.

This course is available to graduates in acupuncture or Chinese herbal medicine or equivalent. Applications from practitioners of acupuncture or Chinese herbal medicine who do not hold an undergraduate degree will be assessed on an individual basis; prior learning and professional experience in Traditional Chinese Medicine will be recognised for course entry provided that it is deemed equivalent to that required for normal entry. The course is offered on a part-time basis over four semesters.

**Part-time program****Stage 1****Autumn semester**

99599	Principles of Chinese Herbal Medicine	8cp
99600	Graduate Clinic Level 1 (CHM)	4cp

**Spring semester**

99601	Principles of Botany	4cp
99602	Principles of Pharmacognosy	3cp
99603	Classical Herbalism	3cp
99604	Graduate Clinic Level 2 (CHM)	2cp

**Stage 2****Autumn semester**

99605	Herbal Prescriptions	5cp
99594	Chinese Herbal Practice 1	6cp
99595	Graduate Clinic Level 3 (CHM)	2cp

**Spring semester**

98596	Chinese Herbal Practice 2	6cp
99597	Graduate Clinical Internship (CHM)	5cp

For further information contact the Course Coordinator, Traditional Chinese Medicine, telephone (02) 9514 2500, fax (02) 9281 2267, email [Carole.Rogers@uts.edu.au](mailto:Carole.Rogers@uts.edu.au)

## Master of Occupational Health and Safety

**Course code: P055**

*Course coordinator: Dr D Cobbin*

This course involves all the coursework requirements of the Graduate Diploma in Occupational Health and Safety plus an additional year to undertake a substantial research project in an area of particular interest and/or relevance to the student. Students would be permitted to transfer to the Master's program only if they achieved a credit average or better in the coursework. The 24 credit points to be completed in the Master's program involve the following subjects, each allocated 12 credit points:

- 69351 Occupational Health and Safety Project  
69353 Research Proposal (Occupational Health and Safety)

Persons who already have a Graduate Diploma in Occupational Health and Safety or equivalent from this or another university are able to enter the Master's program with advanced standing. They would normally be required to complete one semester of appropriate coursework at credit level or better before undertaking the research project.

## Master of Science in Clinical Biochemistry

**Course code: KB55**

*Course coordinator: Dr R Orwell*

This course is designed to provide advanced level professional education and training in clinical biochemistry for professional scientists employed in clinical laboratories, including those currently in senior laboratory positions. The program includes visits to specialised laboratories and engages the services of specialists in different fields of clinical biochemistry from outside the University.

### Objectives

By completing this course students will acquire the theoretical background and practical skills required by the practising clinical biochemist, including:

- diagnostic biochemical analysis in an advancing technological environment;
- statistical and computer techniques for data handling and quality control;
- application of new developments in biomedical science to pathology;
- administration and management of a clinical laboratory, leading to an appreciation of the role of the modern clinical biochemistry laboratory in diagnosis and patient care.

### Duration

The course involves one year full-time or two years' part-time attendance.

### Admission requirements

Candidates may be admitted to the course with any of the following:

1. a three year undergraduate degree plus two years appropriate work experience;
2. a four year undergraduate Honours degree in a relevant field; or
3. evidence of general and professional qualifications equivalent to 1 or 2 above.

**Full-time program****Autumn semester**

91410	Principles of Clinical Biochemistry	8cp
91426	Analytical Techniques in Clinical Biochemistry	8cp
91417	Clinical Laboratory Management	4cp
91474	Statistics in Bioscience	4cp

**Spring semester**

91411	Biochemical Pathophysiology	8cp
91467	Clinical Biochemistry Advanced Aspects	8cp
91419	Case Studies in Clinical Biochemistry	8cp

**Part-time program****Stage 1****Autumn semester**

91410	Principles of Clinical Biochemistry	8cp
91474	Statistics in Bioscience	4cp

**Spring semester**

91411	Biochemical Pathophysiology	8cp
91467	Clinical Biochemistry Advanced Aspects	8cp

**Stage 2****Autumn semester**

91417	Clinical Laboratory Management	4cp
91426	Analytical Techniques in Clinical Biochemistry	8cp

**Spring semester**

91419	Case Studies in Clinical Biochemistry	8cp
-------	---------------------------------------	-----

For further information contact the Course Coordinator, Clinical Biochemistry, Dr R Orwell, telephone (02) 9514 4098, fax (02) 9514 4003, email [Ralph.Orwell@uts.edu.au](mailto:Ralph.Orwell@uts.edu.au)

**Master of Science (Honours) in Clinical Biochemistry****Course code: KB61**

*Course coordinator: Dr R Orwell*

Subject to Academic Board approval.

The Honours degree consists of 48 credit points of study: 24 credit points of coursework and a 24 credit point project. The coursework component will consist of subjects chosen according to the applicant's educational background and will normally consist of subjects selected from those in the Master's program. The project is chosen in consultation with an academic supervisor, which may be undertaken in an approved laboratory or other suitable location under the supervision of a member of staff of the Department of Cell and Molecular Biology.

Candidates who have completed Master's level study in a relevant field with a credit average and at least one-third of the subjects passed at distinction level or better, may be admitted to the Honours program. Depending on applicants' educational backgrounds, exemptions may be granted from among the coursework component.

**Full-time program**

	Coursework subjects	24cp
91466	Individual Research Project – Clinical Biochemistry F/T	24cp

**Part-time program****Autumn semester**

	Coursework subjects	12cp
91458	Individual Research Project – Clinical Biochemistry P/T	12cp

**Spring semester**

	Coursework subjects	12cp
91458	Individual Research Project – Clinical Biochemistry P/T	12cp

## Master of Science in Ecotoxicology

**Course code: KB52**

*Course coordinator: Ms A Pulkownik*

Subject to Academic Board approval.

Ecotoxicology is the science which deals with the toxicity of chemicals in the environment and their impact on organisms, communities and ecosystems. A wide range of chemicals is in current use and their toxic effects need to be monitored. New chemicals are constantly being introduced in every aspect of industrialised society and toxicological data are needed to assess potential hazards. The science of ecotoxicology has, therefore, an intrinsic management goal.

This course provides relevant postgraduate education and training in the developing science of ecotoxicology and is offered in conjunction with the Centre for Ecotoxicology. The Centre is a joint initiative between the New South Wales Environment Protection Authority and the University and is housed in the Dunbar Building, St Leonards campus.

Two programs are available. The Master of Science is a 48 credit point program (coursework only), while the MSc (Hons) is a 48 credit point program with 24 credit points from the coursework component of the Master of Science program and a research project of 24 credit points. The seven subjects in the coursework program cover the essential knowledge and skills for the practising ecotoxicologist, and comprise lectures, tutorials, and supervised laboratory and field work.

### Objectives

The objectives of the course are to provide students with:

- specialist knowledge in the field of ecotoxicology;
- understanding of the mechanism of action and impact of toxic chemicals on the biota;
- skills to design and implement toxicological tests on a variety of organisms and to interpret the results;
- skills to apply analytical techniques and field assessment methodology to evaluate the impact of toxic materials in the environment;
- decision-making skills needed for sound ecosystem assessment and environmental risk assessment and management.

### Duration

Both courses are offered on a full-time or part-time basis. The duration of the Master of Science in Ecotoxicology program in the full-time mode is two semesters or one year, with attendance of 18 hours per week. In the part-time mode the attendance pattern is nine hours per week, over four semesters, or two years. The Master of Science (Honours) in Ecotoxicology comprises 24 credit points from the coursework component of the Master of Science and a one semester full-time or two semesters' part-time project.

### Admission requirements

1. Admission to the course is open to graduates with three year degrees in the biological sciences, chemistry, agriculture, pharmacy, engineering or equivalent disciplines, plus two years appropriate work experience; or a four year Honours degree in a relevant field; or to candidates with general or professional experience equivalent to the above.
2. Admission to the course will involve a selection process and may require personal interviews.
3. Prospective students should have adequate computing skills to be able to use word processing, spreadsheet and simple graphics software packages, email and access the Internet. All assignments and reports will be expected to be submitted in typed or word-processed format. Bridging courses in computing skills can be recommended by the University prior to entry.
4. Prospective students should be proficient in English at the level required by the University (if applicable).
5. Individual subject exemptions may be granted on the basis of previous relevant study or demonstrated employment experience. No more than eight credit points of exemption will be granted. Where subject equivalents to more than eight credit points of previous learning are demonstrated, alternative postgraduate subjects or special assignments will be prescribed by the Course Coordinator.
6. Candidates who have completed Master's level study in a relevant field with a credit average and at least one-third of the subjects passed at distinction level or better, may be admitted to Honours. Depending on applicants' educational backgrounds, exemptions may be granted from among the coursework component.

**Full-time program**

**Autumn semester**

91468	Introduction to Ecotoxicology	8cp
91469	Laboratory Methods in Ecotoxicology	12cp
	<i>either</i>	
91493	Biosystems <sup>1</sup>	4cp
	<i>or</i>	
91474	Statistics in Bioscience <sup>1</sup>	4cp

**Spring semester**

91470	Field Methods in Ecotoxicology	8cp
91440	Experimental Design and Methods	4cp
91494	Ecosystem Assessment	6cp
91495	Environmental Risk Assessment and Management	6cp

**Part-time program**

**Stage 1**

**Autumn semester**

91468	Introduction to Ecotoxicology	8cp
	<i>either</i>	
91493	Biosystems <sup>1</sup>	4cp
	<i>or</i>	
91474	Statistics in Bioscience <sup>1</sup>	4cp

**Spring semester**

91470	Field Methods in Ecotoxicology	8cp
91440	Experimental Design and Methods	4cp

**Stage 2**

**Autumn semester**

91469	Laboratory Methods in Ecotoxicology	12cp
-------	-------------------------------------	------

**Spring semester**

91494	Ecosystem Assessment	6cp
91495	Environmental Risk Assessment and Management	6cp

<sup>1</sup> Subjects will be prescribed according to educational background of the entrant.

All academic inquiries are to be directed to the Course Coordinator in Ecotoxicology, Ms Alex Pulkownik, Department of Environmental Science, Room GH 1.19B, telephone (02) 9514 4035; fax (02) 9514 4003 email A.Pulkownik@uts.edu.au

**Master of Science (Honours) in Ecotoxicology**

**Course code: KB62**

*Course coordinator: Ms A Pulkownik*

**Full-time program**

**Autumn semester**

Coursework subjects	24cp
91497 Ecotoxicology Project F/T	24cp

**Part-time program**

**Autumn semester**

Coursework subjects	12cp
91496 Ecotoxicology Project P/T	12cp

**Spring semester**

Coursework subjects	12cp
91496 Ecotoxicology Project P/T	12cp

**Master of Science in Hydrogeology and Groundwater Management**

**Course code: N057**

*Course coordinator: Professor M J Knight*

This course is designed to enable students to develop specialist skills in the area of groundwater management including aspects of geology, hydrology, hydraulics and resource management. This provides a multi-disciplinary perspective to issues of groundwater management.

**Duration**

The course requires block-release attendance of three periods of one day each for a series of lectures and laboratory work during Autumn semester and project work during Spring semester. The time required to complete the project will be approximately 30 weeks. Students must continue project work until a satisfactory level of achievement has been attained. The course is also available in Distance Mode which has an additional residential component.

## Admission requirements

Applicants must hold a four-year science degree from UTS or an equivalent qualification and should have a minimum of two years' experience in employment related to the course. Applicants are required to submit a covering letter indicating why they wish to undertake the course, together with the names, telephone numbers and addresses of two professional referees.

## Attendance

The course is offered on the basis of block-release attendance extending over one calendar year.

## Course structure

With the exception of Project (24 credit points) and Computing for Groundwater Specialists, all subjects have a credit point value of six.

### Autumn semester

- 66014 Hydrogeology
- 49550 Computing for Groundwater Specialists<sup>1</sup>
- 49555 Groundwater Modelling
- 66015 Hydrogeochemistry
- 49551 Surface Hydrology and Groundwater  
Elective 1  
Elective 2

### Spring semester

- 66021 Groundwater Science Project (M) F/T  
*or*
- 66023 Groundwater Science Project (M) P/T

### Electives

- 49554 Groundwater Computing
- 66016 Geophysics and Remote Sensing of  
Groundwater Resources
- 66017 Geopollution Management
- 66018 Groundwater Geophysics
- 66025 Contaminated Site Management  
An approved subject offered elsewhere

<sup>1</sup> This is a non-credit subject available to students whose computing background requires strengthening.

For further information contact the Course Coordinator, Hydrogeology and Groundwater Management, Professor M J Knight, telephone (02) 9514 1984, fax (02) 9514 1985, email groundwater.management@uts.edu.au

## Master of Science in Medical Microbiology

**Course code: KB57**

*Course coordinator: Dr I Stevenson*

The course offers postgraduate education to graduates in the medical or biological sciences wishing to further a career in medical microbiology or related areas of hospital and medical science, such as diagnostic bacteriology, virology, mycology and parasitology. It is being offered by the Faculty, with involvement of relevant staff from several major Sydney hospitals. The formal coursework consists of lectures, tutorials and supervised laboratory work, some of which may be conducted at hospitals or other laboratories in Sydney. Assessment will be by major assignments, seminar and presentations and in a few cases, formal examination. Admission to the course is open to science graduates of approved tertiary institutions where microbiology has been a significant component of the degree, or persons with equivalent qualifications.

## Objectives

To provide excellent postgraduate education for microbiology professionals.

Graduates of this course will:

- have a wide perspective and current awareness of individual groups of significant micro-organisms in the diagnostic clinical microbiology laboratory;
- be able to attain competence in the application of state-of-the-art diagnostic methods and procedures in their own laboratories;
- appreciate the constraints inherent in many laboratory diagnostic procedures in microbiology;
- be able to assess and apply new and developing methodologies and technologies in the medical microbiology laboratory;
- be able to access current literature and other informational material rapidly and effectively; and
- have the potential to progress to research or research degree studies in microbiology.



**Duration**

The program can be completed in one year of full-time or two years of part-time attendance.

**Admission requirements**

Candidates may be admitted to the course with any of the following:

1. a three year undergraduate degree plus two years appropriate work experience;
2. a four year undergraduate Honours degree in a relevant field; or
3. evidence of general and professional qualifications equivalent to 1 or 2 above.

**Full-time program****Autumn semester**

91480	Epidemiology and Disease Control	6cp
91417	Clinical Laboratory Management	4cp
91487	Research Methodology	6cp
91488	Molecular Microbiology	8cp

**Spring semester**

91481	Current Topics in Clinical Microbiology	4cp
91454	Diagnostic Bacteriology	8cp
91455	Human Parasitology and Mycology	8cp
91457	Immunological Response to Infection	4cp

**Part-time program****Stage 1****Autumn semester**

91480	Epidemiology and Disease Control	6cp
91487	Research Methodology	6cp

**Spring semester**

91454	Diagnostic Bacteriology	8cp
91457	Immunological Response to Infection	4cp

**Stage 2****Autumn semester**

91488	Molecular Microbiology	8cp
91417	Clinical Laboratory Management	4cp

**Spring semester**

91455	Human Parasitology and Mycology	8cp
91481	Current Topics in Clinical Microbiology	4cp

For further information contact the Course Coordinator, Medical Microbiology, Dr I Stevenson, telephone (02) 9514 4154, fax (02) 9514 4003, email [Iain.Stevenson@uts.edu.au](mailto:Iain.Stevenson@uts.edu.au)

**Master of Science (Honours) in Medical Microbiology**

**Course code: KB60**

*Course coordinator: Dr I Stevenson*

Subject to Academic Board approval.

The Honours degree consists of 48 credit points of study: 24 credit points of coursework and a 24 credit point project. The coursework component will consist of subjects chosen according to the applicant's educational background and will normally consist of subjects selected from those in the Master's program. The project is undertaken either in an approved local laboratory or other suitable location or in the Department of Cell and Molecular Biology's laboratories, in each case under the supervision of a member of the Department's academic staff. For projects in an external laboratory, there may also be a co-supervisor from that laboratory.

Candidates who have completed Master's level study in a relevant field with a credit average and at least one-third of the subjects passed at distinction level or better, may be admitted to the Honours program. Depending on applicants' educational backgrounds, exemptions may be granted from among the coursework component.

**Full-time program**

Coursework subjects	24cp
91492 Research Project – Medical Microbiology F/T	24cp

**Part-time program****Autumn semester**

Coursework subjects	12cp
91491 Research Project – Medical Microbiology P/T	12cp

**Spring semester**

Coursework subjects	12cp
91491 Research Project – Medical Microbiology P/T	12cp

## POSTGRADUATE DEGREES BY RESEARCH/THESIS

The Master's and PhD programs are designed for graduates who wish to develop a career in the fields of biological and biomedical sciences as well as physical sciences by undertaking an appropriate research investigation under professional supervision.

The broad areas of research expertise within the Faculty are:

- materials technology
- image processing and analysis
- regional and resource geology
- science education
- cell and molecular biology
- biomedical science and engineering
- environmental biology and toxicology
- groundwater management
- biomedical technology
- forensic and analytical chemistry
- coastal resource management.

Applications are invited for these research programs. Please consult with a potential academic supervisor or appropriate Head of Department before submitting an application.

For further information about the potential supervisors, please telephone the Office of the Associate Dean (Research), telephone (02) 9514 1766, fax (02) 9514 1656.

### Admission to Master's degree (by thesis) program

An application for admission to a Master's degree program is accepted subject to the availability of facilities and supervision. The course can be completed in two years of full-time study or over a minimum of three years part-time. Study can be carried out by means of a cooperative arrangement with the candidate's employer. Applicants should hold at least a Bachelor's degree from UTS, or equivalent, or other general or professional qualifications as will satisfy the Academic Board that the applicant possesses the educational preparation and capacity to successfully complete the course.

#### Master's degrees (by thesis)

Master of Applied Science (Hydrogeology and Groundwater Management)	N056
Master of Science (Biological and Biomedical Science)	KB51
Master of Science (Physical Sciences)	N053

### Admission to PhD program

Applications for the PhD program will be accepted at any time and a decision will be advised following consideration by the relevant research degrees committees. Candidates may be admitted to the program with a Bachelor's degree with First or Second Class Honours Division 1 from UTS, or an appropriate Master's degree from UTS, or an equivalent qualification.

#### PhD programs

Biological and Biomedical Sciences	KB56
Hydrogeology and Groundwater Management	N055
Multidisciplinary Studies	P095
Physical Sciences	N054

# Subject descriptions

---

## Guide to subject descriptions

The subject descriptions shown below indicate the subject code and name, the number of credit points for the subject (e.g. 3cp), the duration of the subject, indicated as semester weeks, if applicable, and the number of formal contact hours each week (e.g. 4hpw); for some subjects, there may also be practical components off-campus, and this is indicated in the text. Also shown are the prerequisites or corequisites if any, the method of assessment and a brief outline of the content.

Prerequisites are subjects which must be completed before taking the subject to which they refer. Corequisites may be completed before or be taken concurrently with the subject to which they refer.

### 44152, 44156

#### Groundwater Engineering Projects (M) F/T, P/T

30cp

These projects will provide students with the opportunity to research specific engineering groundwater resource or contamination problems. The depth and extent of research will vary with credit points required. Projects include one or more of the following: modelling, laboratory experiments, field work related to hydrogeology and groundwater management, contaminant transport and processes, waste disposal and groundwater impact.

### 44153, 44157

#### Groundwater Engineering Projects (GD) F/T, P/T

15cp

As above but at a reduced scale.

### 49121

#### Environmental Assessment and Planning

6cp; 3hpw

Conserving resources and meeting essential needs; industry, urban, energy futures – the need to reorientate technology; ecology and economics. Environmental law: principles; Federal, State and local government responsibilities; environmental impact assessment. The concept of licensing

requirements, approval procedures. Environmental economics: social benefit/cost analysis for environmental services, resource pricing, risk assessment; land-use planning. Project planning – environmental aspects.

### 49122

#### Environmental Engineering and Management Practices

6cp; 3hpw

Ecological systems and processes; basic ecological principles; bio-geochemical cycles; development of ecosystems; interaction between physical ecosystems; global environment issues such as greenhouse effect, ozone depletion and acid rain. Human impact on ecosystems: population growth; terrestrial ecosystems (forest and agricultural land); aquatic ecosystems (lake, river and ocean). Biodiversity; importance of sustainable development. An overview of major environmental problems; their effect and remedies. Air pollution, noise pollution, water pollution, soil pollution, solid and hazardous wastes. Case studies.

### 49123

#### Industrial Waste Minimisation

6cp; 3hpw

Environmental auditing of the product life cycle; leading-edge technologies of waste minimisation and pollution control, raw materials extraction and refinement; product development, design and manufacture; product use; product reuse/recycling; solid/hazardous wastes; liquid wastes. Effective management of the product life cycle; institutional barriers to improving the technologies of waste minimisation and pollution control; reviews of advanced technology and management practices adopted in domestic waste pollution control; economic considerations. Case studies: pulp and paper industry, metal plating industry, food and dairy industry, household waste, waste recycling in buildings.

**49124****Water Quality Management***6cp; 3hpw*

Characteristics of Australian urban water systems: natural features and human infrastructure; benefits and uses of water systems. The sources and nature of major categories of pollutants generated from agricultural, urban and industrial sources; groundwater pollution; beach and coastal pollution; the ecological and public health impacts of pollutants causing siltation. Criteria and designs of monitoring programs; sampling procedures; methods of data analysis; description and modelling of pollution processes. Remedies: regulation of point sources; stormwater and sewer flow controls; groundwater controls etc. Standards, pollution laws, regulatory bodies and responsible organisations (with particular emphasis on New South Wales). Water and waste water treatment processes.

**49550****Computing for Groundwater Specialists***Note: This subject does not carry academic credit.*

Provides the computing background needed for students with varying degrees of computer literacy. Topics covered include introduction to FORTRAN programming, mainframe and microcomputer operation systems, databases, spreadsheets, word processing, statistical and graphical packages with applications relating to groundwater processes.

**49551****Surface Hydrology and Groundwater***6cp*

Provides the interface process link between surface hydrology and groundwater. Topics include hydrological cycle, water and energy balances and circulation, precipitation, interception, infiltration, storm runoff, hydrograph analysis, evaporation and transpiration, surface and groundwater interactions, land-use effects, artificial recharge.

**49554****Groundwater Computing***6cp*

Provides a strong computing basis for groundwater management, especially in the area of statistics and graphics as applied to

groundwater problems involving computing. Introduction to FORTRAN programming, mainframe, microcomputer operation systems, databases, spreadsheets, word processing, elements of geostatistics and graphical packages with applications related to groundwater processes, groundwater computing project.

**49555****Groundwater Modelling***6cp*

Provides the computer-modelling tools required for groundwater resource management. Topics include groundwater modelling of porous media, fractured rock and low permeability materials. Analogue, numerical analytical models. Matrix structure and inverse methods, stochastic modelling and characterisation of variability. Modelling multiphase fluids and regional groundwater flow. Applications to borefield management, salt water intrusion, mine dewatering, geotechnical problems.

**51357****Technical Communication***4cp; 4hpw*

This subject looks at technical communication, report writing and presentation. Topics covered include: visual communication of all types; legal problems of technical communications, including contracts and copyright; standard abbreviations and terminology; editing, preparation and submission of technical manuscripts for publication and/or printing; oral presentation of technical reports; participation in symposia; journal and library research; referencing; and the use of electronic communication media.

**60101****Chemistry and Materials Science**

*6cp; prerequisites: while there are no prerequisites for this subject, it is expected that students will have passed NSW HSC 2 unit Chemistry, the UTS Chemistry bridging course or equivalent*

The objectives of the subject are to develop: an understanding of why engineers require a fundamental understanding of chemistry and materials; a solid science foundation for further engineering studies; an understanding of the fundamentals of chemistry and materials terminology and nomenclature in order to facilitate the working relationship of engineers, chemists and materials scientists; an ability to

identify and solve chemical problems in engineering projects; and an ability to relate to the properties of engineering chemicals and materials in the environment and in manufacturing to their structure and bonding. Topics include: chemical bonding of materials – electronic structure of materials, fundamental bonding concepts, chemical reactions; materials science and engineering – classification of materials, structure property relationship, mechanical properties, ferrous and non-ferrous alloys, engineering ceramics, composites, materials degradation and materials selection; industrial organic chemistry – hydrocarbons, spontaneous reactions, electrochemical cells, electrolysis, electroplating industrial processes, corrosion theory, application and protection.

### 60301

#### Treatment of Scientific Data

3cp; 3hpw; prerequisites: 33171 Science Mathematics 1; 31870 Introduction to Microcomputers

Errors: error calculations, error propagation. Presentation of data and graphical analysis; population and frequency distributions; sampling techniques; Least-squares; applications of concepts to the physical sciences.

### 65012

#### Chemistry 1A

6cp; 6hpw

This subject is an introduction to some fundamental concepts in chemistry. Topics covered are: chemicals and chemical reactions; atomic structure; periodic table; chemical bonding; enthalpy changes in chemical reactions; and the structures and properties of solids. There is a laboratory program which complements the learning experiences in the lectures and tutorials. Other important aims of this subject are to enhance students' thinking skills, to foster their abilities to work cooperatively with their peers and to assist in the development of their communication skills.

### 65022

#### Chemistry 2A

6cp; 6hpw; prerequisite: 65012 Chemistry 1A

This subject builds on, and expands the knowledge and understanding of, 65012 Chemistry 1A. It seeks thereby to give students completing one full-time year a broad and general understanding of inorganic, organic

and physical chemistry concepts, knowledge and practice.

The organic chemistry topics covered are: alkanes, alkenes, alkynes and aromatic hydrocarbons; alcohols, phenols and ethers; aldehydes, ketones, carboxylic acids and their derivatives; amines; organic halogen compounds; stereochemistry. The physical chemistry concepts are: reaction kinetics; chemical equilibrium; and acid-base theory.

The laboratory work seeks to impart practical skills and to demonstrate the theory and reactions taught. The subject aims to enhance students' thinking skills, to foster their ability to work cooperatively with their peers, and to assist in the development of their communication skills.

### 65031

#### Thermodynamics

3cp; 3hpw; prerequisites: 67201 Materials Science 1; 33172 Science Mathematics 2; or 65021 Chemistry 2 FIT

First law of thermodynamics, internal energy and enthalpy changes in chemical and physical reactions. Entropy and the second and third laws of thermodynamics. Free energy and chemical equilibria. Phase equilibria. The thermodynamic properties of ideal and non-ideal solutions.

### 65062

#### Extractive Metallurgy

6cp; 6hpw; prerequisites: 65031 Thermodynamics; all Stage 1, 2 and 3 subjects

Occurrence of minerals. Comminution and the theory of time particles. Extractive metallurgy including physical separation methods, flotation, hydrometallurgy and pyrometallurgy.

### 65101

#### Chemistry 1C

6cp; 6hpw; assumed knowledge: core of HSC 2-unit chemistry or equivalent

This subject is an introduction to some fundamental concepts in chemistry. Topics covered are: chemicals and chemical reactions; atomic structure; periodic table; chemical bonding; enthalpy changes in chemical reactions; and the structures and properties of solids. The subject is designed for students with a strong background in chemistry and accordingly the topics are covered to a greater depth than in 65012 Chemistry 1A. There is a

laboratory program which complements the learning experiences in the lectures and tutorials. Other important aims of this subject are to enhance students' thinking skills, to foster their abilities to work cooperatively with their peers and to assist in the development of their communication skills.

## 65201

### Chemistry 2C

*6cp; 6hpw; prerequisite: 65101 Chemistry 1C or equivalent*

This subject builds on the foundation studies in 65101 Chemistry 1C. Topics covered are: chemical equilibrium; acid-base theory; complex ions; electrochemistry; chemical kinetics; structure and bonding in carbon chemistry; chemical reactions of carbon compounds. There is a laboratory program which complements the learning experiences in the lectures and tutorials. The subject also aims to enhance students' thinking skills, to foster their ability to work cooperatively with their peers, and to assist in the development of their communication skills.

## 65202

### Organic Chemistry I

*6cp; 6hpw; prerequisite: 65101 Chemistry 1C or equivalent*

Introduction to organic chemistry. Nomenclature, functional groups, reaction mechanisms, stereochemistry, chemical and instrumental analysis.

## 65241

### Principles of Forensic Science

*6cp; 4hpw*

This subject provides a broad and sound overview of forensic science. It is designed to introduce the different disciplines, principles and concepts peculiar to forensic science. It covers, in the forensic context, the following areas: history, general definitions and concepts, sub-disciplines, methodology and methods, introduction to crime scene, trace typology, function of the expert, legal system, judicial admissibility, ethical considerations, interpretation of forensic evidence. Lectures are complemented by tutorials/workshops involving guest speakers.

## 65301

### Spectroscopy and Structure

*7cp; 6hpw; prerequisite: 65201 Chemistry 2M or equivalent*

An introduction to the theory and practice of structure determination spectroscopic techniques including UV-visible, infra-red, nuclear magnetic resonance and mass spectrometry.

## 65302

### Inorganic Chemistry

*7cp; 6hpw; prerequisite: 65201 Chemistry 2M or equivalent*

Covalent bonding in inorganic molecules. Valence bond theory. Chemistry of the transition elements and introductory coordination chemistry. Crystal field theory. Chelating agents and applications in analytical chemistry.

## 65306

### Analytical Chemistry I (new)

*6cp; 4.5hpw; prerequisite: 65201 Chemistry 2C or equivalent*

Lecture, laboratory and computer-aided instruction components of the course cover: (a) spectroscopic methods of analysis including ultraviolet-visible spectroscopy, nuclear magnetic resonance spectroscopy, mass spectrometry; (b) separation techniques including solvent extraction, distillation; precipitation, and a range of chromatographic methods; (c) volumetric techniques including acid-base, redox, non-aqueous, and potentiometric methods; and (d) errors, calibration and interpretation of analytical data.

## 65307

### Physical Chemistry I

*6cp; 4.5hpw; prerequisites: 65201 Chemistry 2C and 33190 Mathematical Modelling for Science*

This subject is designed to provide students with a working knowledge of chemical thermodynamics and optical spectroscopy which can then be applied to other subjects within the course. Students are introduced to fundamental concepts in both spectroscopy and thermodynamics and learn how to apply these principles in problem-solving situations. Lectures are complemented by tutorials and relevant practical experiments.

**65341****Forensic Imaging**

*6cp; 5hpw; prerequisites: 65101 Chemistry 1C and 65241 Principles of Forensic Science*

This subject is specifically designed for forensic science students. It covers application of light theory in forensic science (absorption/reflexion, UV, IR, diffusion, episcopic coaxial illumination, polarised light, photoluminescence etc.), technical and forensic photography (use of large and medium format and single lens reflex cameras), image treatment, optical and electron microscopy, comparison microscopy. Lectures are complemented by an extensive practical program given in the form of workshops.

**65401****Analytical Chemistry 1 (old)**

*8cp; 6hpw; prerequisites: all Stage 2 subjects; 65302 Inorganic Chemistry*

Lecture and laboratory topics selected from: separation techniques – solvent extraction; distillation; precipitation; chromatography – normal phase, reversed phase and ion chromatography; types of columns; types of separation media; and mobile phases. Volumetric analysis – non-aqueous; complexometric; and redox.

**65402****Organic Chemistry 2 (old)**

*8cp; 6hpw; prerequisites: all Stage 2 subjects; 65301 Spectroscopy and Structure*

Nomenclature of polyfunctional compounds. Methods of structural elucidation. Aromatic reactions and syntheses. Carbanion reactions in aliphatic syntheses. Introduction to polymer chemistry. Carbohydrates and stereochemistry. Introduction to heterocyclic chemistry.

**65403****Electrochemistry**

*4cp; 3hpw; prerequisites: all Stage 2 subjects; 65301 Spectroscopy and Structure*

Revision of basic electrochemical concepts (Nernstian behaviour and conductivity) covered in earlier stages. Molar conductivity and applications. Nature of the electrical double layer, single electrode potentials, thermodynamics and electrode equilibria. pH – potential (Pourbaix) diagrams – their construction, application and limitations. Ionic solutions, activity and activity coefficients – Debye-Huckel theory. Polarisation at electrode

surfaces and basic electrode kinetics – Butler-Volmer relationship. Tafel relationships and behaviour. Mechanisms of selected reactions. Electrochemistry of energy conversion. Electrochemistry of corrosion processes. Experimental methods.

**65404****Chemical Thermodynamics**

*4cp; 3hpw; prerequisites: all Stage 2 subjects; 65301 Spectroscopy and Structure*

Thermodynamic systems and processes. State and path functions. First law of thermodynamics. Standard reference states and calculation of standard enthalpy changes. Heat capacity and variation of enthalpy of reaction with temperature. Thermodynamically reversible and irreversible processes. Entropy function. Second law of thermodynamics. Variation of entropy with temperature. Third law. Absolute standard entropies. Standard and non-standard values for Gibbs free energy changes. Variation of  $G$  with extent of reaction. Equilibrium constants and the reaction isotherm. Fugacity, activity and deviations from ideal behaviour. Van Hoff isochor, Gibbs-Helmholtz equation and applications.

**65409****Analytical Chemistry 2 (new)**

*6cp; 4.5hpw; prerequisite: 65306 Analytical Chemistry 1 (new)*

Lecture and laboratory topics covering: separation techniques; gas chromatography; instrumentation. Sample preparation and derivatisation. Columns-packed and bonded phase. GC detectors and their application. HPLC: Basic theory and instrumentation. Sample preparation. Normal and reversed phase columns. Ion-pair chromatography and gel permeation chromatography. Ion exchange resins and chromatography. Method validation and quality assurance. Electrophoresis: plate and capillary. Laboratory Automation: robotic techniques. Auto samplers. Post-column derivatisation methods.

**65410****Chemical Safety and Legislation**

*6cp; 3hpw; prerequisite: 65201 Chemistry 2C or equivalent*

NSW Occupational Health and Safety Act and role of various governmental agencies. Toxic effects of chemicals. Classification of dangerous goods. Precautionary labels and

material safety data sheets. Corrosives, oxidisers and explosives. Compressed gases. Personal protective equipment PPE in the laboratory. Waste. Good laboratory practice. Good manufacturing practice. QC/QA issues.

### 65411

#### **Inorganic Chemistry 1 (Transition Metal Chemistry)**

*6cp; 4.5hpw; prerequisite: 65201 Chemistry 2C*

Transition metals: electron configurations and oxidation states. Fundamentals of coordination chemistry. Crystal field theory. Spectral and magnetic properties of metal complexes. Chelating agents and applications in analytical chemistry, industrial processes and medicine.

### 65501

#### **Analytical Chemistry 2 (old)**

*8cp; 6hpw; prerequisites: all Stage 3 subjects; 65403 Electrochemistry; 65401 Analytical Chemistry 1 (old)*

Lecture and laboratory topics selected from: electroanalytical chemistry – ion selective electrodes, voltametric methods; spectroscopic analysis – UV/VIS, emission spectroscopy, ICP-AES, flame and furnace AAS, X-ray fluorescence; radiochemistry; flow injection analysis; quality assurance.

### 65502

#### **Chemical Process Control**

*8cp; 6hpw; prerequisites: all Stage 4 subjects*

Process control – measurement, controllers, control valves, processes. Control systems mathematics – block diagram algebra, Laplace Transforms, frequency response. Unit operations – heat exchange, distillation, separation processes. Advanced process control – bypass, cascade, feedforward.

### 65504

#### **Chemical Safety**

*3cp; 2hpw; prerequisites: all Stage 1 subjects; 65201 Chemistry 2M; 65202 Organic Chemistry 1*

Safety in chemical laboratories is covered in this subject. Topics include: various laboratory hazards and their prevention; NSW Occupational Health and Safety Act and the role of Worksafe and Workcover; the toxic effects of chemicals; classification of dangerous goods; precautionary labels and material safety data sheets; corrosives, oxidisers and

explosives; compressed gases; personal protective equipment in the laboratory; and waste handling and the disposal of chemical, biological and microbiological waste.

### 65508

#### **Organic Chemistry 2 (Structure Elucidation and Synthesis)**

*6cp; 4.5hpw; prerequisite: 65202 Organic Chemistry 1*

This subject builds on previous studies of organic chemistry and demonstrates the use of combined chemical and spectroscopic methods UV, IR, NMR and MS in structural elucidation of organic compounds. It also aims to develop the ability to make planned use of simpler organic reactions in the multistage synthesis of new aliphatic and aromatic compounds. The lectures will be complemented by a relevant practical program and tutorial sessions.

### 65509

#### **Inorganic Chemistry 2 (New Inorganic Materials)**

*6cp; 4.5hpw; prerequisite: 65411 Inorganic Chemistry 1 (Transition Metal Chemistry)*

Structures of inorganic solids: crystallography and x-ray diffraction. Inorganic materials: biominerals, clathrates, new carbons, and aluminosilicates. Introductory organometallic chemistry: carbonyls and alkyls. Organometallic compounds as catalysts in industrial organic chemistry.

### 65541

#### **Physical Evidence I**

*6cp; 6hpw; prerequisites: 65241 Principles of Forensic Science and 65341 Forensic Imaging*

This subject covers the nature, value and relevance of several types of physical evidence. It follows on from 65241 Principles of Forensic Science and 65341 Forensic Imaging. It covers fingerprint detection and identification; miscellaneous individual traces, tooth marks, lip prints, nail marks etc.; path marks, footwear impression, tyre impression etc.; weapons including firearms, bullet/cartridge identification, gunshot residues, firing distance; motor vehicle globes and other light; miscellaneous trace evidence, matches, cigarettes/tobacco, building and safe insulation materials, cordage, buttons, wood, and glass. Lectures are complemented by a practical program involving mock cases.



**65542****Forensic Toxicology I (new)**

*6cp; 4hpw; prerequisites: 65306 Analytical Chemistry 1 (new); corequisites: 65508 Organic Chemistry 2 (Structure Elucidation and Synthesis) and 91141 Biological Evidence*

The subject is designed as an introduction to the fundamentals of forensic toxicology. It involves specific forensic material, general pharmacology and toxicology. The practical component is designed to reinforce topics covered in lectures and seeks to give students experience in analytical problems specific to biological systems, which relies to some extent on the techniques they learnt in both 65306 Analytical Chemistry 1 and 91141 Biological Evidence. The subject also gives students an overview of State and Federal laws concerning licit and illicit drugs and poisons.

**65551****Analytical Chemistry 2 (Advanced)**

*8cp; 6hpw; prerequisites: all Stage 3 subjects; 65401 Analytical Chemistry 1 (old); 65403 Electrochemistry*

Additional material for Honours students: PC-based data acquisition and control. Additional assignment topics related to advanced chemical instrumentation techniques.

**65557****Forensic Toxicology I (old)**

*5cp; 4hpw; prerequisites: 65401 Analytical Chemistry 1 (old); 65402 Organic Chemistry 2 (old)*

The aim of this subject is to familiarise students with the fundamental concepts of pharmacology and toxicology. Topics covered include basic pharmacological principles such as absorption, distribution, metabolism and excretion of xenobiotics. The subject includes an introduction to the Poisons Act and drugs that act on synaptic and neuroeffector junctional sites.

**65601****Environmental Chemistry**

*8cp; 6hpw; prerequisites: all Stage 4 subjects; 65501 Analytical Chemistry 2 (old)*

The chemical nature and control of natural and polluted systems in the atmosphere, geosphere, biosphere and hydrosphere. The use of modern analytical techniques in study of such systems.

**65602****Reaction Kinetics**

*4cp; 3hpw; prerequisites: all Stage 4 subjects*

Rates of chemical reactions, including order determination and experimentally determined rate laws. The use of analytical techniques to monitor reaction course. Analysis of the mechanism(s) by which a reaction occurs. Heterogeneous reactions and simple collision theory. Activation energy and the effect of temperature on reaction rates. Critical evaluation of pharmacokinetic data, and implications of kinetics for optimisation of industrial processes.

**65603****Surface Chemistry**

*4cp; 3hpw; prerequisites: all Stage 4 subjects*

Interfacial phenomena, surface active agents, catalysis, rheology.

**65606****Analytical Chemistry 3 (new)**

*6cp; 4.5hpw; prerequisite: 65306 Analytical Chemistry 1 (new)*

Lecture and laboratory topics covering: (a) electrochemical analysis methods, ion selective electrodes, calibration methods, standard addition etc. (b) spectroscopic methods such as AA, ICP, ICP/MS and XRF; trace analysis and matrix effects; (c) estimation of uncertainty in analytical chemistry, accuracy, precision, gross errors, sensitivity, selectivity and linearity; (d) error propagation in analytical chemistry, systematic and random errors.

**65607****Physical Chemistry 2**

*6cp; 4.5hpw; prerequisites: 65307 Physical Chemistry 1; 65411 Inorganic Chemistry 1 (Transition Metal Chemistry)*

Rates of chemical reactions, including order determination and rate laws. The use of analytical techniques to monitor reaction course. Activation energy and the effect of temperature on reaction rates. Basic electrochemical concepts. Molar conductivity and applications. Nature of the electrical double layer, single electrode potentials, thermodynamics and electrode equilibria. Pourbaix diagrams; Debye-Huckel theory; Butler-Volmer and Tafel relationships. Electrochemistry of energy conservation. Electrochemistry of corrosion processes.

**65641****Physical Evidence 2**

6cp; 6hpw; prerequisite: 65541 Physical Evidence 1

This subject complements the material covered in 65541 Physical Evidence 1. It covers forensic analysis of soil, paint, fibres, hairs and documents. Lectures are complemented by an extensive practical program involving mock cases. At the end of this subject, the students should be able to select appropriate analytical procedures, analyse, interpret and write an expert witness report describing the forensic analysis of the material covered in 65541 Physical Evidence 1 and 65641 Physical Evidence 2.

**65642****Forensic Toxicology 2 (new)**

6cp; 4hpw; prerequisites: 65542 Forensic Toxicology 1 (new); 65508 Organic Chemistry 2 (Structure Elucidation and Synthesis)

The subject is designed and delivered as an advanced course covering specific aspects of forensic toxicology. These aspects are approached from a practical perspective, dealing in some depth with analytical details of the areas covered. The subject is designed to be taught alongside 65741 Chemistry and Pharmacology of Illicit Drugs, enabling the pharmacology and toxicology of drugs such as cannabis, amphetamines, opiates and cocaine, to be taught in parallel with other aspects of these drugs.

**65651****Environmental Chemistry (Advanced)**

8cp; 6hpw; prerequisites: all Stage 4 subjects; corequisite: 65551 Analytical Chemistry 2 (Advanced)

Additional material for Honours students: Honours students will be required to submit two additional assignments and complete one additional, more challenging practical class. They will also be required to do additional reading from current research publications.

**65656****Forensic Examination of Physical Evidence 2**

6cp; 4hpw; prerequisites: all Stage 4 subjects; 65556 Forensic Examination of Physical Evidence 1

This subject considers the collection, examination, identification and comparison of physical evidence commonly found at a crime scene. Such evidence includes footwear impressions, tool marks, globes, firearms (weapon, bullet and cartridge case comparison, gunshot residues, range of fire), glass, soil and miscellaneous trace evidence. The lecture material is complemented by an extensive laboratory program.

**65657****Forensic Toxicology 2 (old)**

8cp; 6hpw; prerequisites: all Stage 4 subjects; 65551 Analytical Chemistry 2 (Advanced); 65557 Forensic Toxicology 1 (old)

This subject covers the chemistry and pharmacology of drugs important in forensic toxicology such as ethanol, antidepressants and antipsychotic agents. Other topics include the toxicology of asphyxia, drugs in sport, solvent abuse and naturally occurring poisons. The subject has a strong emphasis on analytical aspects of forensic toxicology.

**65702****Applied Organic Chemistry 2**

8cp; 6hpw; prerequisites: all Stage 4 subjects

This subject looks at selected advanced topics in organic chemistry, focusing on organic reaction mechanisms, photochemistry and spectroscopic elucidation of organic structures.

**65703****Metallurgical Chemistry**

8cp; 6hpw; prerequisites: all Stage 4 subjects

Occurrence of minerals. Comminution and the theory of time particles. Extractive metallurgy including physical separation methods, flotation, hydrometallurgy and pyrometallurgy.

**65704****Coordination and Organometallic Chemistry***8cp; 6hpw; prerequisites: all Stage 4 subjects*

Spectral and magnetic properties of coordination compounds. Applications of thermodynamics and kinetics to inorganic chemistry. Organometallic chemistry: theory and industrial applications. Coordination chemistry and catalysis.

**65705****Corrosion Science***8cp; 6hpw; prerequisites: all Stage 4 subjects*

The course provides a detailed survey of the various forms of corrosion, and the use of appropriate anti-corrosion techniques are discussed in terms of modern theory and practice. Some attention is given to the economics of alternative anti-corrosion methods. Lectures are complemented by extensive practical work which emphasises the applied nature of the subject.

**65741****Chemistry and Pharmacology of Illicit Drugs***6cp; 5hpw; prerequisites: 65508 Organic Chemistry 2 (Structure Elucidation and Synthesis); 65409 Analytical Chemistry 2*

This subject aims to familiarise students with the pharmacology, chemistry, methods of analysis and legal status of a wide range of drugs of abuse. It examines the pharmacology of the various classes of drugs opioids; amphetamines and other stimulants; hallucinogens; cannabis; miscellaneous drugs including alcohol and tobacco products; route of synthesis and profiling of drugs to determine route of manufacture; sampling and analysis protocols; State and Federal legislation covering the manufacture and importation of certain drugs; case studies; and social issues.

**65742****Fire and Explosion Investigation***6cp; 3hpw; prerequisite: 65641 Physical Evidence 2*

This subject seeks to show how a systematic scientific examination of a fire or explosion scene can lead to the establishment of its origin and cause. It covers general definitions; fire insurance and crime statistics; combustion process, external and internal scene examination, fire origin and cause

determination; physical properties of materials, gases, aerosols; spontaneous combustion; kitchen fires, cigarettes, heaters, motor vehicle fires, electric appliances; accelerants, explosives; sniffers and canines; and computer modelling of fires.

**65743****Complex Forensic Cases (Chemistry)***6cp; 6hpw; prerequisites: 65641 Physical Evidence 2, 65642 Forensic Toxicology 2 (new) and 91141 Biological Evidence; corequisite: 79991 Complex Forensic Cases (Law)*

This subject is designed as an advanced practical course where the students apply techniques and principles gained in previous forensic subjects to the analysis of mock cases. It aims to familiarise the students with the management of a complex forensic case involving more than one type of evidence. It involves forensic analysis of material previously studied, preparation of expert witness reports and preparation for presenting evidence in a court environment.

**65752****Applied Organic Chemistry 2 (Advanced)***8cp; 6hpw; prerequisites: all Stage 4 subjects*

Additional material for Honours students: interpretation of homonuclear and heteronuclear decoupling experiments and nuclear Overhauser effects. Fragmentation mechanisms in mass spectrometry. Photochemical reactions of aromatic compounds. Reactions involving cleavage of weak single bonds.

**65753****Metallurgical Chemistry (Advanced)***8cp; 6hpw; prerequisites: all Stage 4 subjects*

Additional material for Honours students: roast reduction calculations. Calculations of blast furnace charges. Solvent extraction. Computer analysis of grinding and flotation circuits.

**65754****Coordination and Organometallic Chemistry (Advanced)***8cp; 6hpw; prerequisites: all Stage 4 subjects*

Additional material for Honours students: kinetics and mechanisms of reactions of organometallic compounds. Library assignment. Advanced project work.

**65756****Forensic Examination of Physical Evidence 3**

*6cp; 4hpw; prerequisites: all Stage 4 subjects; 65556 Forensic Examination of Physical Evidence 1*

This subject provides further development in the application of the techniques of forensic examination of physical evidence. Topics include the forensic study of hairs and fibres, paints, various polymers and other microtraces. The technical examination questioned document is also considered (inks, paper, photocopy toner etc.).

**65757****Narcotics and Drugs of Abuse**

*5cp; 4hpw; prerequisites: all Stage 4 subjects; 65551 Analytical Chemistry 2 (Advanced); 65557 Forensic Toxicology 1 (old)*

The topics to be covered include sources of drugs, profiling, sampling protocol and the identification and analysis of opioids, amphetamines, hallucinogens etc.

**65758****Fire Investigation**

*5cp; 4hpw; prerequisites: all Stage 4 subjects; 65551 Analytical Chemistry 2 (Advanced); 65556 Forensic Examination of Physical Evidence 1*

This subject seeks to show how a systematic scientific examination of a fire scene can lead to the establishment of the fire's cause and origin. Topics include the chemical processes involved in fires, the properties of building materials and fuels, spontaneous combustion, sampling and analysis of fire debris, and vehicle and commercial fires.

**65851****Project 1 (Chemistry)**

*8cp*

The project component of the Honours degree in Chemistry comprises this subject and 65852 Project 2. To complete the Project, students should be enrolled in two consecutive (not concurrent) semesters. Projects are generally carried out in the Department of Chemistry, Materials and Forensic Science and should relate to current problems or developments in Chemistry. Students are expected to translate their project design into action, developing an appropriate methodology, collecting data and subjecting them to critical evaluation and scientific presentation.

**65852****Project 2 (Chemistry)**

*16cp; prerequisite: 65851 Project 1*

The project component of the Honours degree in Chemistry comprises this subject and 65851 Project 1. To complete the project, students should be enrolled in two consecutive (not concurrent) semesters. Projects are generally carried out in the Department of Chemistry, Materials and Forensic Science and should relate to current problems or developments in Chemistry. Students are expected to translate their project design into action, developing an appropriate methodology, collecting data and subjecting them to critical evaluation and scientific presentation.

**65853****Honours Seminar**

*8cp*

In this subject, advanced chemistry topics are further developed through lectures, direct reading and electronic data retrieval. The nature of specific topics presented will depend on staff interests and availability. Students are expected to demonstrate high level interpretation and communication skills.

**65854****Honours (Chemistry)**

*2 semesters, 24cp per semester; prerequisite: BSc in Applied Chemistry or equivalent 3 yr degree*

Study designed to enhance the skills and knowledge necessary for research in chemistry. The principal activity is an individual research project in which the student, under supervision, plans and undertakes investigations in an area of interest. The data collected are then subjected to analysis and interpretation under the guidance of the supervisor. Students learn to define objectives and aims, work to available time and resources, use appropriate research methods, critically assess information and develop complex arguments in detail. The findings of the research project are presented in a structured and integrated thesis which comprises the main assessment component.

**65856****Forensic Research Project**

*24cp; at least 25hpw; prerequisites: all Stages 1–7 subjects*

A research project on specific aspects of forensic science will be conducted under the

## 112 SUBJECT DESCRIPTIONS

joint supervision of a member of the academic staff of the University and an external (industrial) supervisor. Some of the work may have to be conducted at sites away from UTS.

### 65858

#### Honours Research Project

24cp; 2 semesters; prerequisites: all Stages 1–7 subjects

Defining a research project. Research aims and relationship to available time and resources. Establishing previous work and critical assessment of methodology and results. Appropriate research methods, data collection, data manipulation, logical development of detailed complex arguments. Research ethics. Structure and presentation of research findings.

### 65990

#### Master's Thesis (Applied Chemistry) F/T

### 65991

#### Master's Thesis (Applied Chemistry) P/T

### 65995

#### Industrial Training (Applied Chemistry Honours)

prerequisite: average mark of at least 65 for Stages 1–4

A minimum of one semester working as a member of a group involved in professional practice in chemistry. The student will be placed in a challenging position requiring initiative, scientific judgment and team work.

### 65996

#### Industrial Training 1 (Applied Chemistry)

First six months full time.

### 65997

#### Industrial Training 2 (Applied Chemistry)

Second six months full time.

### 65998

#### Industrial Training (Applied Chemistry) P/T

### 66014

#### Hydrogeology

6cp

Provides a knowledge of geological occurrence and hydraulics of groundwater flow, exploration techniques, extraction engineering and field management.

### 66015

#### Hydrogeochemistry

6cp

Covers the chemical basis for understanding how the chemistry of groundwater evolves both naturally and in the case of contamination. Both practical field measurement and computer modelling will be covered.

### 66016

#### Geophysics and Remote Sensing of Groundwater Resources

6cp

A theoretical and practical examination of the geophysical and remote sensing techniques applicable to groundwater resources evaluation and other environmental problems.

### 66017

#### Geopollution Management

6cp

The relationship between groundwater contamination and water quality, together with appropriate waste management and disposal methods for minimal environmental impact. Contaminated land issues are also addressed.

### 66018

#### Groundwater Geophysics

6cp

This subject presents an advanced application of geophysical techniques for groundwater research and resource management, and includes contamination assessment and monitoring.

### 66021, 66023

#### Groundwater Science Projects (M) F/T, P/T

24cp

These projects will provide students with the opportunity to research specific hydrogeology groundwater resource or contamination problems. The depth and extent of research

will vary with credit points required. Topics include investigation consisting of one or more of: modelling, laboratory experiments, field work related to hydrogeology and groundwater management, contaminant transport and processes, waste disposal and groundwater impact.

### **66022, 66024**

#### **Groundwater Science Projects (GD)**

**F/T, P/T**

*12cp*

As above but at a reduced scale.

### **66025**

#### **Contaminated Site Management**

*6cp*

To develop an understanding of the methodology and technology used in the assessment and remediation of contaminated sites.

The subject content includes: regulatory requirements, site assessment methodology, physical, chemical and biological properties and behaviour of contaminants, health issues, risk assessment, site assessment technology, remediation techniques and operation.

### **66034**

#### **Groundwater Geology**

*4cp; prerequisites: 66101 Earth Science I; 66409 Surficial Processes and Products; 33101 Mathematics 1 LS or equivalent; 65101 Chemistry 1C or equivalent*

Basic concepts of hydrogeology; effective porosity, hydraulic conductivity of geologic materials, occurrence and flow of water in aquifers and soils; the unsaturated zone; regional groundwater concepts. Elements of aqueous geochemistry. Water wells.

### **66062**

#### **Earth Systems and the Environment**

*4cp; 2hpw*

Introduction to Earth systems including life cycles of oceans, global sea level variation, atmosphere and climate evolution and change, greenhouse gases, the water cycle; evidence for the age of the Earth and the evolution of life; natural geological hazards, their causes and predictability; Earth resources and their sustainable use; energy production from fossil fuels and other sources; Antarctica; its resources and future; waste disposal.

### **66101**

#### **Earth Science I**

*6cp; 6hpw*

The dynamic Earth: earth materials; earth structure and the evolution of the continents and oceans; geological history; geological structure of Australia; landscape development; groundwater; engineering geology; resource and environmental geology. Three full-day field excursions.

### **66204**

#### **Field Studies I**

*6cp*

An introduction to field techniques in the earth and environmental sciences. Topographic and other maps; introduction to air photographs and satellite imagery; land tenure; ethics and safety in the field. Methods for systematic study – gridding, transects, maps and plans on the local scale. Thematic maps. Basic geological and soil mapping. Biogeology. Sampling and data recording techniques. Surficial deposits. Stratigraphic principles. Tracing landscape changes through time. Much of the subject, which will include a one-week excursion, will be taught in the field.

### **66301**

#### **Mineralogy and Petrology**

*2 semesters, 4cp per semester; prerequisite: 66202 Lithology*

Crystal symmetry and Miller Indices; optical theory; use of the polarising microscope; optical properties, chemistry and paragenesis of rock-forming minerals; crystallisation paths of igneous minerals: occurrence, mineralogy and texture of igneous rocks; nature of magma and its cooling behaviour; magmatic differentiation; sources of magma – nature of crust and upper mantle; igneous rock associations. Types of metamorphism and textures of metamorphic rocks; chemical equilibria and metamorphic mineral reactions; concept of metamorphic zones and facies; metamorphic rock association. Microscopic and megascopic description of rock types. Five-day field camp with 66302 Sedimentary Geology.

**66302****Sedimentary Geology**

*6cp; 5hpw; corequisite: 66301 Mineralogy and Petrology*

Nature and origin of sedimentary materials and stratigraphic sequences including processes of weathering, transportation, deposition and diagenesis. Sedimentology of principal depositional environments; petrographic and textural analysis of sediments; nature and identification of clay minerals; introduction to palaeontological techniques. Field work.

**66303****Geochemistry**

*3cp; 3hpw; corequisite: 66301 Mineralogy and Petrology*

Abundance and distribution of elements and their geochemical classification. Crystallochemical concepts and structure and classification of common minerals. Fundamentals of chemical thermodynamics and application of thermodynamics to geological systems. Isotopy. Aqueous geochemistry and its significance in chemical weathering, chemical sedimentation, diagenesis and metamorphism.

**66304****Earth Materials**

*6cp; prerequisites: 33101 Mathematics I LS; 66101 Earth Science I*

The first part of the subject deals with the fundamental matter of natural materials, particularly related to solid state substances. The second part deals with the determination of structure, and chemical and isotope composition of minerals, rocks and soils. Particular emphasis is given to the understanding of modern analytical tools in identification, classification and interpretation of natural materials, and which can also be applied to biological samples, metals, and fluids.

**66305****Fold Belts and Cratons**

*6cp; prerequisite: 66204 Field Studies I*

Stress and strain in rocks. Classification of common geological structures including folds, faults, joints, and foliations. Assemblages of imposed structures at different crustal levels. Deformation in space and time. Present day deformation and its relationship to plate

boundaries. Relationship between metamorphism, the emplacement of large plutonic masses and plate setting. Presentation, manipulation and interpretation of structural data on maps, cross-sections and stereo nets. Use of the Mohr circle.

**66402****Structural Geology**

*7cp; 6hpw; prerequisites: 66301 Mineralogy and Petrology; 66302 Sedimentary Geology*

Stress, strain, rheological concepts, and problems pertaining to rock deformation: classification, recognition and formation of fracture systems in brittle and transitional environments; classification, recognition and formation of structures in ductile environments: collection and analysis of structural data in mine, field and laboratory data presentation: mineralisation in the structural environment. Field work.

**66403****Economic Geology**

*4cp; 3.5hpw; prerequisites: 66301 Mineralogy and Petrology; 66302 Sedimentary Geology*

Introduction to the nature of ore bodies: genesis, classification and laboratory methods of investigating such deposits. Field guides to mineralisation: field investigation of mineralisation. Field work.

**66404****Resource Management**

*3cp; 3hpw; prerequisite: 66202 Lithology*

Determination of reserves and resources on a global scale. Definition of reserve categories in use in Australia. The structure and financing of mining companies including financial evaluation techniques using discounted cash flows. Stock exchange operation. Metal marketing and cartels. The New South Wales mining laws: comparison with law in other States. Government policies with respect to the mining industry and the effects of political decisions on mining operations; ethics in the mining industry and the geological profession.

**66405****Basin Analysis**

*4cp; 3hpw; prerequisites: 66201 Geological Mapping; 66302 Sedimentary Geology; 66406 Exploration Geophysics*

Techniques of stratigraphic dating and correlation; interpretation of modern and

ancient depositional environments; palaeo-current analysis; provenance, dispersal and diagenesis; relations between basin structure, tectonism and sedimentation. Field work.

### 66406

#### Exploration Geophysics

*4cp; 3.5hpw; prerequisites: 66203 Geodynamics; 66201 Geological Mapping; 31871 Computing for Science*

Introduction to common methods of air and ground geophysics; theory, technique and equipment; interpretation principles; limitations, particularly in differing parts of Australia. Applications of selected techniques in regional exploration, ground follow-up and target detailing. Down-hole methods of geophysics; geophysical logging. Integration of geophysics with other exploration techniques within ongoing exploration programs. Field work.

### 66407

#### Mapping and Remote Sensing

*6cp; prerequisites: 66305 Fold Belts and Cratons; 66304 Earth Materials*

Properties of EM radiation and interaction with Earth's atmosphere. Qualitative and quantitative analysis and interpretation of aerial photographs. Data acquisition and use in scientific surveys. Satellite imagery including Landsat TM and SPOT data. Microwave radar and thermal imaging. Computer-based image enhancement and interpretation of digital data. Introduction to geographic information systems. Subject includes an extended field excursion dealing with geological mapping and interpretation of field data.

### 66408

#### Earth Resources

*6cp; prerequisite: 66305 Fold Belts and Cratons; corequisite: 66409 Surficial Processes and Products*

Introduction to the nature of ore bodies including genesis and classification. Laboratory investigation of ore deposits. Introduction to exploration methods and reserve estimation for mineral deposits. World energy market, geology of fossil fuels deposits including coal and associated strata, oil, natural gas and synfuels derived from oil shale, tar sands and other petroliferous sediments. Concepts of exploration and resource estimation.

### 66409

#### Surficial Processes and Products

*6cp; prerequisites: 66101 Earth Science I; 65101 Chemistry 1C or equivalent; 91311 Biology I*

Formation of soil and its characteristics. Soil classification and distribution in Australia. Biota of Australian soils and their role in the ecosystem function. Plant soil interactions. Soil function in ecosystem determination and structure. Fundamentals of sedimentary materials and their classification. Hydrodynamics and the processes of sediment transport and deposition. Sediments as substrates: sediment/biota interactions and their function in palaeoecological reconstructions. Process/response sedimentary models and the sedimentology of the principal depositional environments including fluvial, marginal and marine systems.

### 66501

#### Engineering and Environmental Geology

*5cp; 6hpw and four-day field excursion; corequisite: 66402 Structural Geology*

Fundamental concepts in environmental planning. Geologic hazard recognition and planning. Environmental aspects of geological resource utilisation. Mine rehabilitation. Soil classification. Landscape features; hydrogeology; geopollution issues. Rheological properties of rocks and soils. Soil compaction for engineering purposes. Engineering rock mass concepts and classification. Engineering testing of rock and soil materials. Groundwater geology, hydrology, exploration and development. Soil and rock slope stability. Engineering geology in dam, reservoir, road and railway planning and design.

### 66502

#### Advanced Petrology

*4cp; 3.5hpw; prerequisite: 66301 Mineralogy and Petrology; corequisite: 66505 Advanced Structural Geology*

Mineral stability fields in the crust. Constitution of the crust and upper mantle. Origin of basaltic magmas. Partial melting and fractional crystallisation hypotheses. The 'pyrolite' model. Orogenic igneous rock associations. Petrological evolution of the crust and upper mantle. Experimental metamorphic reactions. Metamorphic facies. Mineral



parageneses in metamorphic rocks. Eclogites. Metamorphic belts. Metamorphism and crystal evolution. Field work.

### 66503

#### Fossil Fuels

4cp; 3.5hpw; corequisites: 66302 *Sedimentary Geology*; 66405 *Basin Analysis*

World energy market. Geology of fossil fuel deposits including coal and associated strata, petroleum, natural gas and synfuels derived from oil shale, tar sands and other petroliferous sediments. Introduction to methods of resource size estimation. Field work.

### 66504

#### Exploration Geochemistry

2cp; 3hpw; corequisite: 66403 *Economic Geology*

Introduction to geochemical exploration; sampling theory; statistical data processing and presentation; sample security; soil, sediment stream, rock and vegetation surveys; design of a geochemical exploration program.

### 66505

#### Advanced Structural Geology

4cp; 3.5hpw; prerequisites: 66402 *Structural Geology*; 66403 *Economic Geology*; corequisite: 66502 *Advanced Petrology*

Elastic, plastic and viscous behaviour in relation to the deformation of mono- and poly-mineralic aggregates; microfabric studies – grain boundary relationships, preferred orientation and the application of the U-stage; theoretical advances in the formation of folds, foliations and lineations; metamorphism and deformation in space and time – progressive deformation relationships on hand-specimen, mine and regional scales; metamorphism, deformation and remobilisation of ore deposits; tectonics and ore distribution; the evolution with geologic time of structure, tectonics and ore deposits. Field work.

### 66506

#### Advanced Geological Mapping

3cp (field work); prerequisites: 66201 *Geological Mapping*; 66402 *Structural Geology*

Regional and detailed geological mapping using topographic, air photo and plan bases. Field measurement techniques. Position specification and location by visual, compass, altimeter and GPS methods. Recording field data. Use of information derived by remote sensing and geophysical surveys. Report

preparation and data compilation. Presentation of geological maps and sections. Oral presentation of mapping results.

### 66507

#### Project Seminar

3cp

In preparation for 66604 Field Project, students are assigned seminar topics which include a literature search on an area of interest, background reading on relevant theoretical topics, and practical or field exercises designed to develop skills applicable to the particular Field Project proposed.

### 66508

#### Crustal and Mantle Processes

8cp; prerequisites: 66304 *Earth Materials*; 66305 *Fold Belts and Cratons*

Mantle-crust interactions as expressed by igneous activity at ocean ridges, intra-plate settings and subduction zones. High pressure metamorphic processes and products at convergent margins. Crustal processes responsible for the formation of metamorphic rocks and sedimentary basins. Basic concepts of thermodynamics and experimental geology are introduced during the subject. A significant part of the assessment involves completion of an individual project which aims to develop investigation skills and use of analytical equipment.

### 66509

#### Tectonics and Surface Dynamics

4cp; prerequisite: 66101 *Earth Science 1*

Modern plate boundaries and their evolution. Tectonic elements of the Earth; plate boundary and intraplate tectonics. Tectonic development of Australia including its surrounding oceans. Interactions between tectonics and climate, ocean dynamics, plant and animal biogeography, and erosion. Natural hazards.

### 66510

#### Geophysics

4cp; prerequisite: 68041 *Physics 1A*; 66101 *Earth Science 1*; 66408 *Earth Resources*

Review of solid Earth geophysics including seismicity, magnetism, and gravity. Geophysical techniques applied to subsurface investigation of engineering, environmental and exploration sites, including resistivity, gravity, magnetics and seismic refraction and reflection techniques. Down-hole geophysics techniques. Two-day field excursion.

**66551****Advanced Structural Geology (Honours)***5cp; prerequisites: all Stage 4 subjects*

Elastic, plastic and viscous behaviour in relation to the deformation of mono- and poly-minerallic aggregates; microfabric studies – grain boundary relationships, preferred orientation and the application of the U-stage; theoretical advances in the formation of folds, foliations and lineations; metamorphism and deformation in space and time – progressive deformation relationships at hand – specimen, mine and regional scales; metamorphism, deformation and remobilisation of ore deposits; tectonics and ore distribution; the evolution with geologic time of structure, tectonics and ore deposits. Field work.

**66552****Advanced Petrology (Honours)***5cp; prerequisites: all Stage 4 subjects*

Mineral stability fields in the crust. Petrological constitution of the crust and upper mantle. Fractionation processes in igneous petrology. The generation of basaltic magmas. Partial melting and fractional crystallisation hypothesis. The diversity and occurrence of basaltic rocks. Orogenic igneous rock associations. Temporal and spatial distribution of andesites. Granite diversity and origin. Pyroclastic rocks in the volcanic succession. Experimental metamorphic reactions and metamorphic facies. Metamorphism and crustal evolution. Metamorphism of the mafic/ultramafic rocks – regional metamorphism, burial metamorphism, blueschists, eclogites, sea-floor metamorphism. Metamorphism of pelites – regional metamorphism, granulites, low pressure pelitic metamorphism. Field work.

**66553****Fossil Fuels (Honours)***5cp; prerequisites: all Stage 4 subjects*

Overview of the world energy market and the historical development of the fuels industries. Geology of fossil fuels deposits, including coal and associated strata, petroleum, natural gas and synthetic fuels derived from oil shale, tar sand and other petroliferous sediments. Methods of resource size estimation. Geological aspects of the occurrence of fossil fuels in Australia and Papua New Guinea is covered in a research assignment. Three-day

field trip to examine coal industry in the Hunter Valley.

**66601****Exploration and Mining Geology***4cp; 4hpw; prerequisites: 66402 Structural Geology; 66403 Economic Geology*

Principles of project initiation and continuation; functions of the controlling on-site geologist; exploration programs and budgeting; critical path analysis. Prospect analysis using discounted cash flow methods. Relation of exploration programs to geological models. Prospecting methods and follow-up techniques. Drilling: commonly used methods; logging of drill products; interpretation of results. Drill-sections, level plans, grade and recovery predictions, reserves estimation. Mineral processing.

**66602****Tectonics***3cp; 3hpw; prerequisites: 66201 Geological Mapping; 66502 Advanced Petrology*

Origin and evolution of the Earth's continental crust. Change in tectonic regime and time. Large-scale geologic cycles, major Precambrian–Cambrian boundary divisions. Archaean geology and tectonics. Granite/greenstone and high-grade metamorphic terrains. Proterozoic crystal associations, special characteristics and tectonics. Reactivated basement models. Plate tectonics and crystal evolution. Plate tectonics and orogeny. Wilson cycle. Collision and activation orogenics. Tectonics of present-day plate margins. Case studies of the Red Sea/African Rift System (divergent), Gulf of California/San Andreas (transform) and Himalayan (convergent) boundaries. Detailed study of sea-floor spreading in the Mesozoic/Cenozoic. Concept of tectonostratigraphic terranes. Tectonic evolution of Australia.

**66603****Remote Sensing***3cp; 3hpw; corequisite: 66201 Geological Mapping*

Utilisation of differing parts of the electromagnetic spectrum in remote sensing. Distant and near remote sensing; radar and infra-red imagery; traditional black-and-white, and colour air-photography; multispectral photography and scanning; satellite imagery. Emphasis will be on geological applications of

remote sensing in reconnaissance mapping, geotectonics, and mineral exploration. Practical work will predominantly involve principles of air-photo interpretation.

**66604****Field Project**

*9cp; 9hpw; prerequisite: 66507 Project Seminar*

This is an assignment to be carried out under supervision of a specified member of staff. The assignment combines a literature search, field mapping and/or sampling, and a short laboratory investigation. Assessment is based on a formal typed report submitted to the supervisor before the last week of the semester.

**66605****Advanced Fossil Fuels**

*4cp; 4hpw; prerequisite: 66503 Fossil Fuels*

Exploration and production techniques for coal and petroleum deposits. Reservoir engineering and development of petroleum fields. Assessment of coal and gas reserves. Geological factors in coal mine development and operation. Economic assessment and risk analysis.

**66606****Mineral Deposits**

*4cp; 3hpw; prerequisites: 66402 Structural Geology; 66403 Economic Geology*

Case studies of classical metallic and non-metallic mineral deposits; their genesis in the light of current theories of ore formation; evidence adduced from field and laboratory studies. Classification of mineral deposits relative to environment and method of formation. Field work.

**66607****Advanced Engineering Geology**

*4cp; 4hpw; prerequisite: 66501 Engineering and Environmental Geology*

Quantification of geologic data for engineering purposes; stress and deformation in soil and rock masses, especially near surface excavations and underground openings; special techniques for field and laboratory investigations; evaluation and development of groundwater resources, probabilistic analysis of soil and rock slope stability.

**66608****Mineral Science Project**

*2cp; 2hpw*

A report and seminar prepared by the student on the mineral science project.

**66609****Environmental and Quaternary Geology**

*8cp; prerequisite: 66409 Surficial Processes and Products*

Quaternary allocyclic factors that influence Earth systems and their consequences. Milankovich cycles, ice ages, eustatic fluctuations and climate change: recordings of these in earth systems, their elucidation therefrom, and the consequences of these and other major influences on the geosphere-biosphere. 'Greenhouse' concepts and their relationship and responses to natural and anthropogenic input. Geologic hazards and their recognition, management and alleviation. Pollution and anthropogenic interference with earth systems and the problems that arise therefrom. Recognition of these environmental problems and methods for their control and remediation.

**66610****Engineering Geology**

*4cp; prerequisites: 66101 Earth Science I; 66409 Surficial Processes and Products; 33101 Mathematics I LS or equivalent; 65101 Chemistry IC or equivalent*

Chemical weathering and clay mineralogy. Rheological properties of rocks and soils. Engineering rock mass concepts and classification. Engineering site investigations, aspects of testing of soils and rocks. Soil and rock slope stability; concepts of urban development.

**66651****Convergent Margin Tectonics (Honours)**

*3cp; prerequisites: Stage 5 Honours subjects*

Review of geology and geophysics of convergent margins. Basic tectonic elements. Temporal and spatial variability of modern margins. Outline geology of the New England Fold Belt – an ancient convergent margin. Field study of Devonian and Carboniferous tectonic elements in New England – magmatic arc, arc-fringe, fore-arc basin, ophiolites, and off-scraped and underplated accretionary

complexes. Critical appraisal of tectonic models, the tectonostratigraphic terrane approach.

### 66653

#### Applied Clastic Basin Analysis (Honours)

3cp; prerequisites: Stage 5 Honours subjects

Detailed examination of clastic sedimentary environments with particular emphasis on sandstone body deposition and orientation. The applications of genetic stratigraphy and seismic stratigraphy are examined using real practical exercises on seismic and well data. On a field trip to the Sydney Basin and New England Fold Belt outcrops of fluvial, seashore marine and deep marine environments are examined in detail to demonstrate the three-dimensional nature of deposits.

### 66654

#### Research Developments in Geoscience

3cp; prerequisites: Stage 5 Honours subjects

The subject is based around a series of nine 50-minute seminars given by Doctoral students, academic staff and visiting professional geoscientists. Students will be required to read specified reference material prior to the seminars, and to discuss this material, together with points arising out of the presentation, during a closely following tutorial.

### 66854

#### Honours (Geoscience)

2 semesters, 24cp per semester; prerequisite: BSc in Earth and Environmental Science or equivalent 3 yr degree

Study designed to enhance skills and knowledge in undertaking scientific research in geology. Comprises 12cp of electives in a specialist field and a 36cp equivalent individual research project where the student, under supervision, defines a problem in an area of interest, and then collects, analyses and interprets data to solve this problem. Students learn to define objectives and aims, work to available time and resources, use appropriate research methods, critically assess information and to develop complex arguments in detail. The findings of the research project are presented in a structured and integrated thesis which comprises the main assessment component. Research ethics and scientific method are emphasised.

### 66855

#### Honours (Environmental Science)

2 semesters, 24cp per semester; prerequisite: BSc in Earth and Environmental Science or equivalent 3 yr degree

Study designed to enhance skills and knowledge in undertaking research in environmental science. Comprises 12cp of electives in a specialist field and a 36cp equivalent individual research project where the student, under supervision, defines a problem in an area of interest, and then collects, analyses and interprets data to solve this problem. Students learn to define objectives and aims, work to available time and resources, use appropriate research methods, critically assess information and to develop complex arguments in detail. The findings of the research project are presented in a structured and integrated thesis which comprises the main assessment component. Research ethics and scientific method are emphasised.

### 66858

#### Project (Honours)

28cp; 2 semesters; prerequisites: Stage 5 Honours subjects

Defining a research project. Research aims and relationship to available time and resources. Establishing previous work and critical assessment of methodology and results. Appropriate research methods, data collection, data manipulation, logical development of detailed complex arguments. Research ethics. Structure and presentation of research findings.

### 66990

#### Master's Thesis (Applied Geology) F/T

### 66991

#### Master's Thesis (Applied Geology) P/T

### 66995

#### Industrial Training (Honours)

prerequisites: Stage 4 subjects

A minimum of one semester working as a member of a group involved in professional practice in applied geology. The student will be placed in a challenging position requiring initiative, scientific judgment and team work.

**66996****Industrial Training 1 (Applied Geology)***prerequisites: 66201 Geological Mapping; 66202 Lithology*

The first period of at least six months' full-time relevant industrial employment is necessary to satisfy this subject. The employment must have the approval of the Head of Department of Applied Geology.

**66997****Industrial Training 2 (Applied Geology)***prerequisites: Stage 4 Applied Geology course*

The second period of full-time relevant industrial employment. Only in exceptional circumstances, and with permission of the Head of Department, may formal subjects be undertaken concurrently with this subject.

**66998****Industrial Training (Applied Geology) P/T****67021****Materials Engineering I***3cp; prerequisites: 46110 Mechanics I; 65023 Engineering Chemistry*

A basic introduction to materials science. It provides a foundation in terms of microscopic structure and composition for the understanding of the behaviour of engineering materials. Topics dealt with include atomic structure of solids, phase diagrams, properties of metals and alloys, corrosion, polymers and rubbers, ceramics, timber and composites.

**67023****Materials Technology***3cp; prerequisite: 68031 Engineering Physics I (Electrical)*

The objectives are to develop the student's familiarity with commonly used electrical engineering materials to the extent that he or she would classify them in order of hardness, strength, thermal and electrical conductivity, density, dielectric constant and permeability. Materials covered include ferrous and non-ferrous metals, plastics and ceramics. The subject includes the topics of measurement of material properties, and joining techniques. General production techniques and the selection methods are covered but the emphasis is placed on the properties and

selection of metals ceramics, polymers and composites in electronic devices and instruments.

**67061****Materials Engineering 2***3cp; prerequisites: 33222 Engineering Mathematics 2B; 42631 Mechanics 3*

An introduction to the behaviour of mechanical vibrations. The content includes free and forced response of spring/mass/damper systems, two- and multidegree of freedom systems, torsional vibrations and transverse vibration of beams. Laplace transformation, mechanical impedance and matrix methods are used, and both analytical and computer-based numerical solutions are presented.

**67101****Introduction to Materials***6cp; corequisite: 65101 Chemistry 1C or equivalent*

A basic introduction to materials science. It provides a foundation in terms of microscopic structure and composition for the understanding of the behaviour of engineering materials. Topics include classification and structure of solids, phase diagrams, properties of metals, ceramics, polymers, timber and composites.

**67303****Mechanical Properties of Materials***6cp; prerequisite: 33190 Mathematical Modelling for Science; 67101 Introduction to Materials*

This subject provides an understanding of the mechanical properties of materials by the use of standard mechanical tests and the determination of materials property data. The concepts of stress, strain, elasticity, plasticity and criteria for yielding and fracture are addressed and applied to a wide range of mechanical test methods and materials. The issue of fractography as a means failure analysis is also addressed. Basic statics is introduced to the student along with an introduction to fracture mechanics. This subject also ensures that the student develops the necessary laboratory and analysis skills required by professionals involved in the mechanical testing of materials for either research or quality assurance.

**67304****Physical Metallurgy**

*6cp; 6hpw; prerequisites: 67303 Mechanical Properties of Materials; 67101 Introduction to Materials*

This subject provides an understanding of the theory of phase transformations in metal and alloys. Solidification and solid-solid transformations of metals and alloys are studied in relevance to the phase transformation theory. Deformation mechanism and annealing behaviour of metals and alloys are studied in terms of modern theory and practice. Attention is also given to application of the industrial processes and their effects on the microstructure-texture-property development of metallic materials.

**67305****Polymer Science**

*6cp; 6hpw; prerequisites: 65201 Chemistry 2C; 67101 Introduction to Materials or equivalent*

This subject provides an introduction to the chemistry and physics of polymers. Comprehensive coverage of the structures, reaction mechanisms and characterisation techniques of polymers is provided. Practical classes provide experience with relevant techniques and complement the theory presented in lectures. The applications of polymers are also addressed.

**67306****Industrial Ceramics**

*6cp; 6hpw; prerequisites: 67101 Introduction to Materials; 65201 Chemistry 2C*

Fundamentals of ceramic science and technology, ceramic phase diagrams – binary and ternary systems, ceramic structures and phase transformation, clay-based ceramics, cements and concretes, and glasses. Raw materials and manufacturing methods.

**67407****Physical Properties of Materials**

*6cp; 6hpw; prerequisites: 67101 Introduction to Materials; 68201 Physics 2; 33190 Mathematical Modelling for Science; 65201 Chemistry 2C*

An introduction to atomic structure and quantum mechanics serves to develop the band theory of solids at an intermediate level. These theoretical concepts are utilised in describing the electrical, thermal, magnetic and optical properties of metals, semi-conductors and insulators. The characteristics and

structure of high temperature superconductors are discussed. The unique properties of these materials are emphasised by an examination of devices including capacitors, diodes, thermocouples, loudspeakers, recording heads, strain gauges, information storage, fibre optics and so on.

**67408****Industrial Metallurgy**

*6cp; 6hpw; prerequisites: 67303 Mechanical Properties of Materials; 67304 Physical Metallurgy*

The subject provides an understanding of application of metallurgical principles and theoretical concepts to the present and developing metal processing technologies, including foundry and casting technology, metalworking processes, welding technology, surface finishing and powder metallurgical techniques. The theory and application of non-destructive testing techniques are studied for examination of metal components and structures. Attention is also given to the environmental impact and the latest recycling technology of metals and alloys.

**67409****Polymer Technology**

*6cp; 6hpw; prerequisites: 67305 Polymer Science; 67303 Mechanical Properties of Materials*

This subject provides a comprehensive coverage of the properties of polymers and processing methods used in their manufacture. Practical classes provide experience with such processing methods and the relevant mechanical testing techniques.

**67410****Instrumentation for Materials Scientists**

*3cp; 3hpw; prerequisites: 67101 Introduction to Materials; 65011 Chemistry 1; 31871 Computing for Science*

This subject provides a background in sensors, transducers, analogue and digital electronics, interfacing techniques and modern instrumentation relevant to the needs of materials scientists and chemists in the practice of their professions. The subject matter will be of an applied nature and will include: advantages of electronic techniques for measurements; methods of specification and purchase of instruments to achieve best technical value per dollar; DC and AC circuits; filters; input impedance and measurement; working voltage and power rating of

components; transducers and sensors for measurement of pH, strain (e.g. strain gauges), temperature (e.g. thermocouples), displacement (e.g. LVDT), force, pressure, and ion concentration; operational amplifiers; comparators; zero cross-over devices; phase measurement; negative feedback; bandwidth; 3dB limits; analogue to digital conversion; digital instruments, advantages; opto-electronic couplers; digital integrated chips and microprocessors; computer interfacing; datatakers; examples of modern instruments used by chemists and materials scientists.

## 67506

### Technical Ceramics

*6cp; 6hpw; prerequisites: 67306 Industrial Ceramics; 67303 Mechanical Properties of Materials*

This subject covers the physical aspects of the Technical Ceramics. Structural imperfections are covered using Kroger-Vink notations and industrial electronic ceramics are introduced as practical examples. Free energy curves for ceramic materials are covered and spinel diagrams and related ferrite and aluminate structures are introduced. Diffusion, densification, sintering theories, grain growth and other sintering problems. Molecular engineering of advanced ceramics, oxides, nitrides, sialons in general. Advanced ceramics production methods. Glass ceramics, thermal coatings, mechanical properties, reliability and probability analysis in ceramic materials. Toughening mechanisms in ceramics. Magnetic and electronic and opto-electronic ceramics. Optical fibre production and technology.

## 67507

### Composites (old)

*4cp; 4hpw; prerequisite: 67303 Mechanical Properties of Materials*

This subject covers the following topics: mechanical properties, fracture mechanics and failure analysis of polymer, metallic and ceramic matrix composites; properties of fibres, weaves, fabrics and pre-pregs, their manufacturing and processing requirements; properties of advanced materials and composites and their selection; advanced polymers, copolymers and polymeric matrix composites; and the design and properties of high temperature metal alloys and metal matrix composites.

## 67602

### Surface Properties of Materials

*4cp; 4hpw; prerequisites: 65031 Thermodynamics; 67409 Polymer Technology; 67408 Industrial Metallurgy; 67306 Industrial Ceramics*

This subject contains a detailed treatment of basic surface chemical concepts, techniques and applications of liquid and solid systems. Equilibrium thermodynamics is used to define surface energies. Adsorption/desorption phenomena are described by kinetic modelling techniques as well as by the unique properties in solution and their absorption characteristics. The control of the electrical nature of solid surfaces is examined and applied to the stability of colloidal systems. Much of the fundamental phenomena covered in the subject is applied to the understanding of adhesion, lubrication and wear.

## 67605

### Design and Selection of Materials

*3cp; prerequisites: 67306 Industrial Ceramics; 67506 Technical Ceramics; 67305 Polymer Science; 67409 Polymer Technology; 67304 Physical Metallurgy; 67408 Industrial Metallurgy; 67507 Composites (old); corequisite: 67606 Corrosion and Degradation of Materials*

This subject is an examination of the design-making processes which an engineer/scientist employs to originate, evolve and produce a device, a machine component or structural system. Material selection and specification, a critical factor in this process, is examined with regard to material characteristics, in-service performance, aesthetic factors, the environment, and other considerations in the design process. Practical design and brainstorm sessions are used along with specialised practical design and material selection lectures.

## 67606

### Corrosion and Degradation of Materials

*6cp; 6hpw; prerequisites: 67408 Industrial Metallurgy; 67506 Technical Ceramics; 67409 Polymer Technology*

This subject provides a detailed survey of the forms and mechanisms of corrosion of metallic materials and the degradation of non-metallic materials. The use of appropriate non-corrosion and anti-degradation methods is considered in terms of modern theory and practice. Attention is also given to the

economics of materials selection and degradation protection and control techniques. Lectures are complimented by an extensive practical program which emphasises the applied nature of the subject.

### 67608

#### Composites (new)

*6cp; 4hpw; prerequisites: 67303 Mechanical Properties of Materials; 67409 Polymer Technology; 67506 Technical Ceramics; 67408 Industrial Metallurgy*

The subject draws together the concepts the students have developed on metals, ceramics and polymers and applies them to the incorporation of these materials to form composites in order to develop material properties that are unobtainable in the monolithic counterparts. Appreciation of why composites are used and what advantages they can give the designer/engineer over monolithic materials are given. Students will gain a basic knowledge of composite design and cost analysis in the use of composites. In addition students will obtain an understanding of the processing methods used to produce composite parts. Also included is an examination of the decision-making processes that materials scientists employ to originate, evolve and produce a device. Material selection and specification is examined and is not limited to composite materials.

### 67652

#### Advanced Materials and Characterisation

*8cp; 6hpw; prerequisites: completion of Stages 1–5 of the Bachelor of Applied Science in Materials Science*

This subject deals with advanced materials and advanced analytical methods. Modern theories of structure/property relationships based on thermodynamics and quantum and electromagnetic theories. Analytical methods including electron microscopy, spectroscopy, radiation, thermal, electrical and magnetic techniques. Emphasis on interdisciplinary approach to the development of specialist materials and their characterisation.

### 67751

#### Honours Project Proposal

*4cp; 4hpw; prerequisites: completion of Stages 5 & 6 of the Bachelor of Applied Science (Honours) in Materials Science*

Defining and planning a research project. Research aims and relationship to available time and resources. Reviewing previous research work and critical assessment of methodologies and results.

### 67851

#### Honours Project

*20cp; 20hpw; prerequisites: completion of Stage 7 of the Bachelor of Applied Science (Honours) in Materials Science*

Application of appropriate research methods, data collection, data manipulation, logical development of detailed complex arguments. Research ethics. Structure and presentation of research findings. Preparation of articles for publication in journals and at conferences.

### 67854

#### Honours (Materials Science)

*2 semesters, 24cp per semester; prerequisite: BSc in Materials Science or equivalent 3 yr degree*

Study designed to increase skills and knowledge necessary for research in materials science. The student selects an individual research project and, under supervision, formulates a research plan for a problem in an area of interest. Planning is based upon a critical review of the technical literature and methodologies. Appropriate goals are set within definite time frames and resources to ensure the objectives are fulfilled. Students gain practical experience in applying advanced analytical methods through sophisticated instrumentation to characterise the structural aspects and properties of the material under investigation. Data collected from these measurements are evaluated by testing the statistical significance and establishing empirical relationships between experimental variables. Interpretation of the data and the establishment of models from accepted modern theories to explain the empirical findings enhance the creative skills of the student. The findings of the research project are presented in a structured and integrated thesis which comprises the main assessment.



**67990****Master's Thesis (Materials Science)  
F/T****67991****Master's Thesis (Materials Science)  
P/T****67995****Industrial Training (Honours)***prerequisites: Honours Stages 5 and 6*

A minimum of one semester working as a member of a group involved in professional practice in materials science. The student will be placed in a challenging position requiring initiative, scientific judgment and team work.

**67996****Industrial Training 1 (Materials Science)**

Industrial training provides students with work experience relevant to their studies and an opportunity to apply their academic skills in the workplace. During the training period students learn to extend their knowledge of principles, techniques and technologies gained from the academic program and to integrate work and study experiences.

**67997****Industrial Training 2 (Materials Science)**

Industrial training provides students with work experience relevant to their studies and an opportunity to apply their academic skills in the workplace. During the training period students learn to extend their knowledge of principles, techniques and technologies gained from the academic program and to integrate work and study experiences.

**67998****Industrial Training (Materials Science)  
P/T****68036****Physical Modelling**

*6cp; prerequisites: NSW HSC 2 unit Mathematics is assumed, and HSC 2 unit Physics is recommended; corequisite: 33132 Mathematical Modelling 1*

The objectives of the subject are to develop a conceptual basis in mechanics, thermal physics, waves and optics, electric and magnetic fields; problem solving skills; an

appreciation of the role of modelling in understanding and describing the natural world; the basic techniques of physical measurement, data analysis and verification of models; technical communication skills; an ability to use physical concepts in a mathematical formulation and apply those concepts to engineering problems.

Topics include: mechanics – vectors, motion (linear and rotational), Newton's laws, circular motion, friction, energy, momentum, elasticity and fluids at rest and in motion; heat and thermodynamics – kinetic theory, temperature, heat capacity, heat transfer, ideal gas, first law and Carnot cycle; waves – including superposition of waves, light and EM spectrum; optics – mirrors, lenses, optical instruments, optical and wave behaviour; electric and magnetic fields – electrostatics, magnetism and magnetic materials, magnetic fields, electromagnetism and electromagnetic applications.

**68038****Advanced Mathematics and Physics**

*6cp; prerequisites: 68036 Physical Modelling; 33130 Mathematical Modelling 1; 33230 Mathematical Modelling 2; 48510 Introduction to Electrical Engineering; 48520 Electronics*

The objectives of the subject are to develop the mathematical skills and foundations required to describe a range of electrical engineering and engineering science systems; provide an introductory understanding of key concepts in modern physics that underpin modern electrical engineering technologies; equip students with a basic understanding of the dielectric and magnetic properties of key electrical engineering materials and introduce some fundamental insights into select electronic and photonic devices and transducers.

Topics include: boundary value problems, value problems, solution of select partial differential equations, separation of variables, vector calculus, physical attributes, Greens and Stokes theorems, field and potential operators, Cauchy-Reimann conditions, functions of a complex variable, basic analytical properties, harmonic functions, Cauchy's integral formula, contour integrals and residues, conformal transformations and mapping, photons and electrons as quantum entities, energy levels in atoms, molecules and semiconductors, absorption and emission transitions and electron momentum, the p-n junction.

**68041****Physics IA***6cp; 6hpw*

General introduction to mechanics, wave motion, optics, thermal physics, properties of matter and modern physics.

**68071****Applied Physics (Materials)***4cp; 4hpw; prerequisite: 68201 Physics 2*

This subject is specifically designed for materials science students. It covers interference and diffraction, lasers, optical fibres, thick lenses, lens aberrations, photometry, the basic principles of photography, image analysis, polarisation, vacuum systems, deposition techniques, thin films, glow discharges, ion beams, thermal sensors and important diagnostic techniques such as ultrasonics and radioisotopes.

**68101****Physics IC***6cp; 6hpw*

This is a foundation physics subject primarily for students in the physical sciences. It covers the fundamentals of dynamics and statics, fluid mechanics, thermal physics, electricity and waves. Students are introduced to the basic techniques of measurement.

**68201****Physics 2***6cp; 6hpw; prerequisite: 68101 Physics 1C*

This subject covers the fundamentals of electrostatics, electromagnetism, optics and atomic and nuclear physics, as well as extending the Physics 1C coverage of mechanics, thermal and fluids.

**68311****Physics 3***6cp; 5hpw; prerequisites: 68201 Physics 2; 33290 Computing and Mathematics for Science*

This subject builds on the concepts introduced in earlier physics material, employing first year mathematical techniques to extend the understanding and modelling of mechanics and optics and embrace the exciting developments of modern physics, this then providing the foundation of later core physics subjects. Mechanics topics will include the generalisation of kinematics to 3D motion, orbital mechanics and the dynamics of

complex systems. Optics studies will include refraction, lenses, dispersion of light, aberrations, polarisation and scattering phenomena. Modern physics will study the basic properties of the atom, radioactivity and relativity, leading into a foundation study of quantum mechanics. Elective modules of interest to medical science students may be available. The emphasis of the subject is theoretical but laboratory work will be extended from the explorative first year treatment to optical experimentation, study of radioactivity and computer simulation of dynamical systems.

**68312****Applied Physics I***6cp; 5hpw; prerequisites: 68201 Physics 2; 33290 Computing and Mathematics for Science*

This subject covers three main areas of activity, electromagnetism, the practical implementation of physical concepts and the analysis of experimental data. The concepts of electricity, electromagnetism and electrical measurements are developed and used as the context to explore the processes of science and scientific investigation and emphasising skills such as experimental design, scientific writing and analysis of experimental data. This is a key to providing students with the confidence, skills and flexibility to design, implement and analyse scientific experiments.

**68314****Electronics***6cp; 5hpw; prerequisites: 68201 Physics 2 and either 33190 Mathematical Modelling for Science or 33130 Mathematical Modelling I*

This subject will develop students' understanding of the basic building blocks of electronic circuits. Review of circuit theory, semiconductors theory, diodes and bipolar transistors, transistors as switches and linear devices, introduction to digital electronics, logic gates, latches and counters, frequency characteristics and feedback in amplifiers, operational amplifiers. Hands on learning, guided discovery activities in lab context. The subject may be offered jointly with the Engineering subject 48520 Electronics. This is team taught by Applied Physics staff and thus can be taken either semester.

**68401****Quantum Physics I**

*3cp; 3hpw; prerequisites: 68301 Physics 3; 33172 Science Mathematics 2; 33173 Science Mathematics 3*

Brief historical introduction, the Schrödinger equation. Time-independent solutions for harmonic oscillator, infinite and finite square wells, hydrogen atom, potential steps and barriers. Angular momentum. Orthonormality, interpretation of solutions.

**68402****Applied Mechanics**

*3cp; 3hpw; prerequisites: 68201 Physics 2; 33221 Engineering Mathematics 2A*

Particle kinetics in various coordinate systems. Vibrations: free, forced and damped vibration of single and coupled oscillators. Energy methods for particles and for rigid body systems. Angular momentum in two and three dimensions. Introduction to fluid mechanics; flow of ideal incompressible and compressible fluids. Flow of real fluids; Navier Stokes equation. Similitude. Applications.

**68403****Thermodynamics and Energy**

*3cp; 3hpw; prerequisite: 68201 Physics 2*

Applications of basic ideas of thermodynamics to the analysis of power generation, refrigeration, heat pumps. Methods of power production: hydrocarbons, alternative energy, energy storage and transportation, solar energy. Temperature measurement; thermocouple, optical pyrometer, resistance thermometry.

**68404****Electronics 2**

*3cp; 3hpw; prerequisite: 68304 Electronics 1 or 68314 Electronics*

Revision of logic gates, Boolean algebra, Karnaugh maps. Decoding and multiplexers. Flip-flops, structure of counting circuits, digital data storage, registers and memory, RAM, ROM, PROM, parallel-serial conversion, arithmetic circuits, D-A/A-D conversion.

**68405****Vacuum and Thin Film Physics**

*3cp; 3hpw; prerequisite: 68201 Physics 2*

Vacuum systems; pumps, system operation and design, gauges, leak detection and mass

spectrometry. Thin film deposition techniques. Glow discharge sputtering, ion beams. Surface processing. Cryogenics.

**68406****Computational Physics**

*4cp; 4hpw; prerequisites: 60301 Treatment of Scientific Data; 31871 Computing for Science; 68201 Physics 2; 33221 Engineering Mathematics 2A*

This subject is an introduction to scientific programming. Topics include: basics of programming development; pseudo-random number generation; Monte Carlo techniques; finite difference techniques for ODES; Fourier transform; DFT; FFT; convolution and correlation; and image processing techniques.

**68411****Physics 4**

*6cp; 5hpw; prerequisites: 68311 Physics 3; 33390 Mathematics and Scientific Software*

The subject fulfils two important functions, namely, to round off the study of classical and fluid mechanics and to build a solid foundation in quantum mechanics for future subjects. Twentieth century technologies of jet propulsion, energy-absorbing materials, nuclear power and lasers are explored through classical and fluid mechanics and vibration, quantum and nuclear physics, including the solution of the one-dimensional Schrodinger equation. Elective modules of interest to medical science students may be available. Although the emphasis of this subject is mostly theoretical, there will be the opportunity for laboratory work in nuclear physics. The use of computer packages for qualitative and quantitative analysis of mechanics and waves is a central feature.

**68412****Applied Physics 2**

*6cp; 5hpw; prerequisite: 68312 Applied Physics 1*

This subject will develop students' organisational skills and provide opportunities to apply the experimental design skills of Applied Physics 1 to larger scale investigations. The broad topic areas covered are vacuum and thin film technology, energy technology and sustainability, and project management. There is a high experimental component, and small group project work will allow students to develop their project management skills. At this stage of the course there is an expectation that students will take

the opportunity to further develop their independent learning skills. Self access resources and the use of the Physics Resources Centre will be a key component of this subject.

## 68501

### Nuclear Physics

3cp; 3hpw; prerequisite: 68401 Quantum Physics I

Core: basic properties of nucleus, scattering theory, nuclear forces, nuclear models, nuclear reactions, passage of energetic particles through matter, nuclear instrumentation. Lobe: fundamental particles, quarks and leptons, 'standard theory', grand unified theories, other current theories. Pass students take the core and a brief summary of the lobe plus extra laboratory work. Honours students take the core and the lobe in more detail.

## 68502

### Field Theory

3cp; 3hpw; prerequisites: 33330 Physical Mathematics; 68303 Electrotechnology

Solution of electrostatic and magnetostatic problems using Laplace and Poisson equations. Separation of variables in rectangular coordinates; method of images. Field in a rectangular trough. Maxwell's equations in integral and differential form; derivation. Power flow, Poynting vector. Electromagnetic waves in unbounded media. Skin effect. Reflection of waves at boundaries.

## 68503

### Materials Physics

3cp; 3hpw; prerequisites: 68301 Physics 3; 68303 Electrotechnology

Dielectric materials: fundamentals; classification of dielectrics; practical applications; relationship between atomic and bulk dielectric properties; dielectric breakdown.

Magnetic materials: classification of materials by magnetic properties; bulk magnetic properties and their measurement; magnetic materials for practical applications. Superconductivity: historical development and applications, categories of materials, electrical and magnetic behaviour.

## 68504

### Microprocessors in Instrumentation

3cp; 3hpw; prerequisites: 31871 Computing for Science; 68304 Electronics I or 68314 Electronics

This subject covers the following topics: computer architecture; assembly language; decoding, system timing, buffering and latches; programmable interface adaptors; data flow; I/O control; Forth language; and LabView. The subject focuses mainly on the Motorola 68000 microprocessor, but the principles covered are directly applicable to the Intel range of microprocessors with only minor modification. Emphasis is on lab work and project type experiments offered towards the end of semester.

## 68505

### Solid-state Physics

3cp; 3hpw; prerequisite: 68401 Quantum Physics I

Electrons in solids; free electrons, ICAO, band theory, nearly free electron, tight binding. Insulators, metals and semiconductors: electrical and optical properties of semiconductors. Lattice vibrations; phonons, specific heat, thermal conductivity and expansion.

## 68508

### Project A

6cp; 2 semesters

A pass project in Applied Physics.

## 68511

### Quantum and Solid State Physics

6cp; 5hpw; prerequisites: 68411 Physics 4; 33490 Computational Mathematics and Physics

This subject will highlight the fundamental nature of quantum mechanics and its application to the understanding of solids. Potential wells, eigenstates and eigenvalues, solutions to SWE in 3 dimensions, LCAO, band theory, electrons and phonons in solids will be explored. Applications of the theory in 1D and 2D devices, the interaction between electromagnetic waves and solids and the quantum mechanical basis for the LASER will also be a key feature. You do not have to be Einstein to understand the quantum mechanical basis of the LASER nor its importance to modern life. A major assignment will be computational and will utilise software skills developed in 33490 Computational Mathematics and Physics.

**68512****Applied Physics 3**

*6cp; 5hpw; prerequisites: 68312 Applied Physics 1 (or equivalent experimental design experience)*

The purpose of this 'capstone' applied physics subject is to provide the opportunity for students to experience applied physics research. Students will be able to develop skills in cutting edge research techniques. Exact topics covered will vary depending on availability of staff. For example, X-ray diffraction, atomic force microscopy, scanning electron microscopy, solar energy materials, advanced optical characterisation, lighting, energy, medical imaging, and parallel computing could be offered. A few background lectures may take place though the subject will be predominantly project and laboratory based. The subject would be a suitable elective for students in all branches of the physical sciences.

**68514****Electronics and Interfacing**

*6cp; 5hpw; prerequisites: 68314 Electronics or 48520 Electronics (or equivalent instrumentation experience)*

The subject will further develop students' understanding of computer interfacing in applied physics and science in general. You will learn how to construct functioning interfaces and the role of digital electronics. Digital electronics, computer interfacing, and the use of the LabView package will be the main components of the subject. A sequence of small projects will involve the design and construction of circuits and interfaces and is a key feature of the subject. This subject would be useful to students in science courses who have an interest in developing their skills in the instrumentation and interfacing areas. Your project work can be oriented to your needs and interests.

**68515****Technology and Innovation Forum**

*3cp; 3hpw; prerequisite: one industrial experience period*

This subject provides an introduction to the technical, financial, legal and personal aspects of the innovation and research-development-commercialisation cycle. Forums will cover the basics of the research and development process, intellectual property and confidentiality, business plans and financing

mechanisms, design, production and marketing issues, and the importance of an international perspective.

**68516****Techniques of Materials Analysis**

*6cp; 3hpw; prerequisites: 67202 Introduction to Crystallography; 68301 Physics 3; 68302 Applied Optics*

X-ray generation, absorption and scattering; space group theory; crystal diffraction theory; application to structure analysis; defects and deformations in crystal, accurate cell dimensions. Quantitative XRF and XRD.

Electron microscopy; electron optics, transmission electron microscopy and scanning electron microscopy. Image formation and contrast mechanisms. Electron diffraction. X-ray microprobe analysis.

**68553****Computer Modelling of Physical Systems**

*3cp; 3hpw; prerequisites: 68406 Computational Physics; 68505 Solid-state Physics; 68502 Field Theory; 68601 Quantum Physics 2*

Particle methods in modelling. Monte Carlo techniques. Numerical solution of ordinary and partial differential equations that arise in the modelling of physical systems.

**68556****Advanced X-ray Techniques**

*4cp; 3hpw; prerequisites: 68301 Physics 3; 67202 Introduction to Crystallography; 33330 Physical Mathematics*

Review of X-ray and neutron scattering theory, coherent and incoherent scattering, intensity calculations for various diffraction systems. Thermal scattering and extinction. Crystal structure refinement and quantitative analysis, Laue symmetry and diffraction pattern calculations. Powder diffractometry, convolution and Fourier transform, mathematical analysis of instrumental diffraction profiles, diffraction line profile analysis of crystallite size, strain and defective structures.

**68557****Advanced Electron Microscopy Techniques**

*4cp; 3hpw; prerequisites: 68301 Physics 3; 68302 Applied Optics; 33330 Physical Mathematics*

Image formation in an electron microscope. Diffraction theories. Contrast mechanisms. The transmission and scanning electron microscope. Microprobe and nanoprobe analysis.

**68601****Quantum Physics 2**

*3cp; 3hpw; prerequisite: 68401 Quantum Physics I; corequisite: 33330 Physical Mathematics*

Quantum mechanics; time-independent perturbation theory, variational principle, applications. Rotational and vibrational spectra of molecules. Multi-electron atoms. Hartree approximation. Interpretation of quantum theory.

**68602****Physical Optics**

*3cp; 3hpw; prerequisites: 68502 Field Theory; 68302 Applied Optics*

Classical physical optics; dispersion, Fresnel equations; polarisation; interference and interferometry; diffraction, the use of Fourier transformers in diffraction; spatial filtering; laser cavities and amplification; coherence, holography, fibre optics.

**68603****Applied Thermodynamics**

*3cp; 3hpw; prerequisites: 68403 Thermodynamics and Energy; 33221 Engineering Mathematics 2A*

Thermodynamic functions and their applications; phase changes, chemical reactions. Statistical physics; thermodynamic probability; Bose, Fermi-Dirac and Boltzmann statistics; Boltzmann's distribution; the partition function; specific heats. Maxwell velocity distribution. Introduction to kinetic theory; mean free path, calculation of coefficients of thermal conductivity and viscosity.

**68604****Principles of Instrumentation**

*3cp; 3hpw; prerequisite: 68406 Computational Physics; corequisite: 33330 Physical Mathematics*

Linear shift-invariant systems. Digital signals and systems. Properties of filters, filter structures. Transfer functions and discrete Fourier transform. Sampling and quantisation of analog signals. The z-transform. FIR and IIR filter structures. Filter synthesis.

**68605****Transducers and Devices**

*3cp; 3hpw; prerequisites: 68304 Electronics I; 68505 Solid-state Physics*

Device physics. Transducers; p-n junction: field effect transistor; microwave devices. Applications: pressure, flow, vibration, acceleration, strain, position, angle. Optical detection: photonic, thermal, wave-interaction (heterodyne). IR, optical, noise, figure of merit, signal and background noise limitations.

**68608****Project B**

*3cp*

An extension of 68508 Project A which is a pass project in Applied Physics.

**68611****Electromagnetics and Optics**

*6cp; 5hpw; prerequisites: 68201 Physics 2; 33490 Computational Mathematics and Physics or equivalent*

The subject's purpose is to consolidate the emphasis on optics and its applications in the course. The development of an understanding of electromagnetic theory and some of its key features, and its relevance to modern telecommunications will benefit scientists and engineers. The subject seeks to consolidate students' understanding of the theory of electromagnetism in the modern world. The topics include derivation, and application, of Maxwell's equations, energy transfer by waves, guided waves and optical fibre technology, optical instrumentation, diffraction and spatial filtering techniques. The emphasis of this subject is conceptual. Students will also engage in an extensive laboratory program in experimental optics. Computer simulation and data visualisation techniques will underpin the electromagnetics theory. Students will be encouraged to explore topics of interest through project activities.

**68652****Device Physics**

6cp; 6hpw; prerequisites: 68505 Solid-state Physics; 68602 Physical Optics; 68404 Electronics 2

Electronics: p-n junction diodes; npn and pnp transistors; field effect transistors. Photonics: detectors and sources of radiation spectral properties; laser diodes; LED; photodiodes; heterodyne systems; signal and background noise; detectability; thermal noise; bit error rate. Anisotropic media, acousto- and electro-optics. Optical modulation. Integrated optoelectronics. Transducers: piezoelectric devices for velocity; acceleration; strain sensors; position and angle sensors including laser gyroscope.

**68655****Advanced Solid-state Physics**

4cp; 3hpw; prerequisites: 68505 Solid-state Physics; 33330 Physical Mathematics

Band structure of solids: tight-binding method; nearly free electron model. Electron dynamics in electric and magnetic fields; low dimensional systems. Lattice dynamics: phonons; Umklapp processes; harmonic and anharmonic potentials. Other topics: superconductivity; phase transitions.

**68711****Physics IS**

for Computing sub-major students  
8cp

Details are as for 68041 Physics 1A.

**68713****Physics for Electronics S**

8cp; 6hpw

A foundation course for the sub-major in electronics. It covers basic mechanics, wave motion and optics: electrostatics, electromagnetism and circuit analysis. An option, recommended in special cases only, is to replace the wave motion and optics with further mechanics including rotational motion.

**68721****Physics 2 S**

for Computing sub-major students  
8cp

Details are as for 68201 Physics 2.

**68741****Quantum Physics I S**

for Computing sub-major students  
4cp

Details are as for 68401 Quantum Physics 1.

**68742****Applied Mechanics S**

for Computing sub-major students  
4cp

Details are as for 68402 Applied Mechanics.

**68743****Thermodynamics and Energy S**

for Computing sub-major students  
4cp

Details are as for 68403 Thermodynamics and Energy.

**68744****Electronics 2 S**

for Computing sub-major students  
4cp

Details are as for 68404 Electronics 2.

**68751****Nuclear Physics S**

for Computing sub-major students  
4cp

Details are as for 68501 Nuclear Physics.

**68753****Materials Physics S**

for Computing sub-major students  
4cp

Details are as for 68503 Materials Physics.

**68754****Microprocessors in Instrumentation S**

for Computing sub-major students  
4cp

Details are as for 68504 Microprocessors in Instrumentation.

**68755****Solid-state Physics S**

for Computing sub-major students  
4cp

Details are as for 68505 Solid State Physics.

**68761****Quantum Physics 2 S***for Computing sub-major students*  
4cp

Details are as for 68601 Quantum Physics 2.

**68763****Applied Thermodynamics S***for Computing sub-major students*  
4cp

Details are as for 68603 Applied Thermodynamics.

**68764****Principles of Instrumentation S***for Computing sub-major students*  
4cp

Details are as for 68604 Principles of Instrumentation.

**68854****Honours (Physics)***2 semesters, 24cp per semester; prerequisite: BSc in Applied Physics or equivalent 3 yr degree*

Study designed to enhance the skills and knowledge necessary for research in physics. The principal activity is an individual research project in which the student, under supervision, plans and undertakes investigations in an area of interest. The data collected are then subjected to analysis and interpretation under the guidance of the supervisor. Students learn to define objectives and aims, work to available time and resources, use appropriate research methods, critically assess information and develop complex arguments in detail. The findings of the research project are presented in a structured and integrated thesis which comprises the main assessment component.

**68858****Project (Honours)***24cp; 2 semesters; prerequisite: 68997 Industrial Training 2 (Physics)*

The project is carried out over two semesters under the supervision of a member of academic staff of the Department of Applied Physics and, if appropriate, an external supervisor. At the end of the first semester the student's work will be assessed on the basis of a short report. Towards the end of the project the student is required to present a talk to a meeting of academic staff. The final report will

represent not only the results of the student's work but also an understanding of their significance, an appreciation of other relevant work in the area of the project and an understanding of the underlying physics of the methods employed.

**68943****Approved External Subject**

3cp

**68946****Approved External Subject**

6cp

**68990****Master's Thesis (Applied Physics) F/T****68991****Master's Thesis (Applied Physics) P/T****68995****Industrial Training I (Applied Physics Honours)***5hpw; prerequisite: preliminary selection into the Honours course in Applied Physics, knowledge of workshop practice and an appreciation of laboratory safety principles*

Students will work for a period of one semester (at least 18 weeks) on a project or projects which involve the application of physical principles to technological problems of some economic importance. The project will be carried out under the direction of an industrial and an academic supervisor.

**68996****Industrial Training I (Physics)****68997****Industrial Training 2 (Physics)****69311****Occupational Health and Safety in Society**

3cp; 2hpw

This subject will cover the psychological, political and sociological dimensions of occupational health and safety, and present them within the context of the overall social system. It will highlight the complexity and diversity of working environments, and the importance of the human agency in constructing and changing them. It will also



explore the strategies available to create safer and healthier working situations.

**69312**

**Occupational Hazard Analysis**

*6cp; 4hpw*

This subject will deal with the identification of the major categories of both safety and health hazards, the analytical techniques and management programs appropriate for dealing with them and the development of policies in occupational health and safety. Models of accident and disease causation, techniques of investigation, emergency hazards and risk assessment will also be covered.

**69313**

**Organisational Behaviour and Communication**

*3cp; 2hpw*

This subject examines the behaviour of people in organisations, and the dynamics of interpersonal and intergroup behaviour. Topics include: interpersonal perception, attitudes and values, motivation, communications, group behaviour, conflicts, leadership, organisation change and adaptation.

**69323**

**Human Factors/Ergonomic Design**

*3cp; 2hpw*

The role of ergonomics/human factors in the creation of a healthy, safe and productive work environment will be covered, including the principles and techniques used in this discipline. The subject will include the principles of ergonomic design and their application to product and equipment design to combine safety with functionality.

**69324**

**Biological Hazards and Toxicology**

*3cp; 2hpw*

This will be an introduction to biological hazards in the workplace, including allergens in airconditioning systems, legionellosis, infecting disorders, food poisoning, and other job associated risks. It will also discuss the principles of environmental and human toxicology, including toxic gases, dusts and chemicals and test methods, hygiene and sanitation.

**69325**

**Data Analysis in Occupational Health and Safety**

*3cp; 2hpw*

The collection and organisation of data, and access to and use of databases are important aspects of the effective management of the occupational health and safety function. This subject will develop understanding and proficiency in these areas with special reference to occupational health and safety and workers' compensation information systems and reference material databases.

**69332**

**Chemical Safety (OHS)**

*3cp; 2hpw*

This subject will deal with the hazardous effects of chemicals on people and the methods of handling and storing chemicals to minimise risks to health and safety.

**69334**

**Occupational Health Services**

*3cp; 2hpw*

This subject will cover the principles underlying the establishment and functioning of an effective occupational health service within an organisation including its role in assessment of the workplace, health assessment, the management of illness and injury and rehabilitation of injured workers.

**69335**

**People and the Physical Environment**

*3cp; 2hpw*

People have a continuing and dynamic interaction with their physical surroundings, and the processes of this interaction must be understood so that they can be designed for and controlled. The subject will deal with both those interactions which are a part of normal processes, such as noise, vibrations and heat, and those which are random and unplanned events. The first of these can be quantitatively assessed and controlled, whereas the latter requires the application of probability and reliability techniques.

**69336****Evaluating Occupational Health and Safety (Construction Industry)**

*6cp; 4hpw; prerequisites: completion of 2 semesters of the Graduate Diploma in Occupational Health and Safety*

This subject focuses on the importance to the occupational health and safety manager of identifying and accessing occupational health and safety research literature sources in order to keep abreast of current issues and emerging technologies in the building construction industry. It is designed to encourage the development of skills in accessing and critically evaluating occupational health and safety research literature in its treatment of current issues in the building and construction industry as well as to develop skills and confidence in evaluating and communicating such information.

**69341****Risk Management**

*6cp; 4hpw*

Risk management is the term applied to a logical and systematic method of identifying, analysing, assessing, treating, monitoring and communicating risks associated with any activity, function or process in a way that will enable organisations to minimise losses and maximise opportunities.

At successful completion of this subject students will have demonstrated that they:

- understand and are able to implement the Australian/New Zealand Standard 4360 in the context of occupational health and safety;
- understand the systems associated with the application of risk management in organisations.

**69342****Legal Aspects of Occupational Health and Safety**

*3cp; 2hpw*

Occupational health and safety is covered by a wide range of legislative Acts and regulations, both State and federal. This subject will introduce students to the important aspects of this legislation, its interpretation, and the implications for the organisation and management of the occupational health and safety function.

**69343****Occupational Health and Safety Management**

*3cp; 2hpw*

This subject will bring together the management aspects of occupational health and safety through group exercises and case studies. It will deal with the role of the occupational health and safety manager in industry, motivation for health and safety, industrial relations issues, current concepts in safety and health, data analysis and collection and the use of records, training for occupational health and safety, and economic aspects of losses associated with accidents, injuries and ill health.

**69351****Occupational Health and Safety Project**

*12cp*

Students are required to undertake a substantial research project in an area of specialisation in occupational health and safety which is of interest and relevance to them. They will be guided and supervised by a member of academic staff from that area. They may also be required to undertake additional coursework in research methods and/or in the specialisation area to supplement the research program.

**69353****Research Proposal (Occupational Health and Safety)**

*12cp; 6hpw (average) over 2 semesters; corequisite: 69351 Occupational Health and Safety Project*

This subject complements 69351 Occupational Health and Safety Project. Each student works independently to review relevant research literature in order to develop a viable research question suitable for investigation in 69351. Students then formulate a specific research plan including selection of appropriate data collection and analysis methods and scheduling the sequence of steps that will be required to answer the question within the available time frame. There is a formal lecture component dealing with research issues. Student seminars and written reports based on different stages of their projects provide experience in writing and presenting research communications.

**91141****Biological Evidence***6cp; 5hpw*

This subject introduces the nature, the value and the relevance of biological materials as forensic evidence. Different methods for the identification of various biological evidence are examined along with the techniques which are used to classify, differentiate and identify the source of biological material. The analysis and interpretation of DNA evidence are emphasised. Lectures are complemented by an extensive practical program including collection procedures, use of PCR technology and population statistics.

**91150****Biology and Ecology***6cp; 6hpw*

The principals of biology and ecology for students majoring in Environmental Engineering and other fields. Structure and function of cells, cell divisions and the role of genetic material in cell function; biodiversity – the classification, distinguishing characteristics of plants, animals and microorganisms and their economic, medical and ecological importance; the physiology of higher plants and mammals and the effects of environmental pollution and disturbance; the principals of population and community ecology, the structure and function of aquatic and terrestrial ecosystems; the effects and management of human impacts on natural ecosystems.

**91207****Plants in the Landscape***8cp; 6hpw; prerequisite: 91206 Plant Production or equivalent*

This subject is designed to develop the student's understanding of the uses of plant materials (especially woody plants) in the landscape as part of the function of open space management. The subject considers the benefits of plants, techniques for selecting appropriate plants of good quality for particular purposes and sites, methods of establishing these plants and management techniques necessary to maintain plant health, including the diagnosis and management of plant problems. Integral to this subject are site visits to open space developments around Sydney and discussions with the managers of these areas.

**91224****Horticultural Production Management***4cp; 3hpw; prerequisites: 91229 Horticultural Financial Management; 91206 Plant Production or equivalent*

Through this subject, the student is expected to develop an understanding of the technical aspects of nursery management and plant production. Cost-benefit analysis will be made of the daily operations of commercial enterprises ranging from plants produced in tissue culture to open area growth of flowers, to the intensive controlled growth of potted plants in greenhouses. Also covered will be the technical aspects of personnel management, and seasonal and budgetary factors involved. Cost-benefit analysis of physical, biological and human resources will be considered. Long-term and construction design of plant production units will be discussed.

**91225****Open Space Management***4cp; 3hpw; prerequisites: 91229 Horticultural Financial Management; 91207 Plants in the Landscape*

Designed to develop the student's understanding of the operation and management of open space amenity areas, such as landscaped parks and gardens, bushland and reserves, and urban streets. Several case studies in open space management are examined and the importance of obtaining accurate information for decision making is highlighted. The subject considers management functions including planning in relation to long-term and short-term goals, organising resources, staff recruitment and development, directing staff and evaluating the achievement of goals.

**91229****Horticultural Financial Management***4cp; 3hpw*

This subject is normally taken in Stage 5 of the course. The principles and practices of business management in a horticultural enterprise are introduced. The subject includes an introduction to accounting methods, balance sheets, stock control, management and legal issues.

**91230****Landscape Design***3cp; 3hpw*

This subject introduces students to landscape studies by considering the significance and interrelationships of landscape, horticulture and human societies in the past, present and future. The subject considers the impact of humans on the landscape, the history of people/plant/landscape interactions including the history of gardens, and the process of landscape design in relation to current practice in Australia.

**91231****Horticulture I***6cp; 6hpw*

This subject introduces students to a wide variety of plant materials used in urban (environmental) horticulture. Plant materials studied include annual, perennial, herbaceous, woody, exotic and native plant species. These plant materials are studied within the context of their uses for the enhancement of urban surroundings. The subject also introduces the student to plant morphology and anatomy in relation to plant function, through the study of plant organs and tissues, with a particular focus on vegetative biology. Also studied are techniques of plant propagation, both sexual and asexual, including seeds, cuttings, budding, grafting, layering, separation and division.

**91232****Horticulture 2***6cp; 6hpw; prerequisite: 91231 Horticulture I*

This subject introduces students to a wide variety of plant materials used in urban (environmental) horticulture. Plant materials studied include annual, perennial, herbaceous, woody, exotic and native plant species. These plant materials are studied within the context of their uses for the enhancement of urban surroundings. The subject introduces students to plant morphology and anatomy in relation to plant function, through the study of plant organs and tissues, with a particular focus on reproductive biology. Also studied are techniques of plant propagation, by both sexual and asexual means. The subject provides an introduction to irrigation systems used in nurseries and open space areas, including computerised systems, and methods of greenhouse environmental control.

**91233****Plant Production and Growth Media***6cp; 6hpw; prerequisites: 65012 Chemistry 1A; 91312 Biology 2*

Cultivation of both exotic and native plants of value in urban horticulture. Skills necessary for the cultivation, selection and modification of stocks for particular situations are developed. The principles of water use, irrigation and associated problems within nurseries and intensive cultivation systems are covered. Also studied are the physical and chemical properties of horticultural potting mixes; methods of analysis; supply of nutrients, water, air and ions; management of potting mixes; and problems with mixes. Formulation and use of growth media; media used in hydroponics.

**91234****Uses of Australian Plants***6cp; 6hpw; prerequisite: 65022 Chemistry 2A; corequisite: 91309 Australian Biota*

The potential of Australian plants for horticultural exploitation e.g. cut flowers, essential oils, source of foods and pharmaceuticals are considered. Identification of Australian plants as promising future plant crops, difficulties experienced in propagation and cultivation and status of this area of horticulture. Students are asked to write a research proposal for a chosen plant to be developed as a horticultural crop with an emphasis on problems related to growing plants in controlled environments or in open situations. Australian tree species which could substitute for exotic trees in urban street planting, or as wind breaks. This subject involves field trips to wildflower farms, botanic gardens and national parks. There is also a 3-day field trip during a study week.

**91236****Plant Tissue Culture***4cp; 3hpw; prerequisite: 91314 Microbiology I*

An introduction to plant cell and tissue culture, and the application of these techniques to cloning, somatic embryogenesis, somaclonal variation, anther and pollen culture, disease indexing and pathogen elimination. The program includes media preparation, nutrient and growth substance requirements; transplanting hardening-off stages of in vitro grown plants. Students are also introduced to experiments involving plant tissue culture

technology. Special emphasis is given to Australian indigenous and rare flora.

### 91237

#### Plant Pathology

*6cp; 6hpw; prerequisite: 91270 Plant Physiology*

This subject provides knowledge of the main group of plant pathogens causing plant diseases, understanding of their mode of attack and a prevention from spread are discussed. The recognition of signs and symptoms is introduced. Influence of environmental conditions on disease development. Methods of prevention are discussed. Visits to Plant Quarantine at Rydalmere, Narara Research Station and Nursery are arranged. Collection, preservation and identification of plant pathogens form a component of this subject.

### 91270

#### Plant Physiology

*6cp; 6hpw; prerequisite: 91312 Biology 2*

Plant interactions with their environment. The acquisition of carbon dioxide, water and nutrients by plants. Photosynthesis. Responses of plants to environmental stress and the recognition of stress conditions. Measurement of plant function and of factors affecting plant performance.

### 91271

#### Plant Genetics and Breeding

*8cp; 6hpw; prerequisites: 91237 Plant Pathology; 91270 Plant Physiology*

Biochemical and cellular processes including molecular genetics and control of genetic activity in cells, and environmental influences amongst individuals and populations. The program introduces students to cloning, somatic cell genetics and hybridisation. The work also includes the control of cell activity by DNA and protein synthesis, and hormonal control of plant processes. The importance of cytoplasmic inheritance will be introduced as will the genetic manipulation of the plant genome. Traditional methods of plant breeding and production of pure seed and stocks will also be covered.

### 91280

#### Current Urban and Environmental Issues A

*4cp; 3hpw; prerequisites: completion of Stages 1–4*

To be undertaken only following prior negotiation on the part of the student with a full-time member of academic staff regarding individual supervision and, in addition, requires special permission of the Head of Department. The subject involves a variable amount of class, desk or field studies. To be undertaken in exceptional circumstances.

### 91281

#### Current Urban and Environmental Issues B

*6cp; 4hpw; prerequisites: completion of Stages 1–4*

To be undertaken only following prior negotiation on the part of the student with a full-time member of academic staff regarding individual supervision and, in addition, requires special permission of the Head of Department. The subject involves a variable amount of class, desk or field studies. To be undertaken in exceptional circumstances.

### 91282

#### Current Urban and Environmental Issues C

*8cp; 6hpw; prerequisites: completion of Stages 1–4*

To be undertaken only following prior negotiation on the part of the student with a full-time member of academic staff regarding individual supervision and, in addition, requires special permission of the Head of Department. The subject involves a variable amount of class, desk or field studies. To be undertaken in exceptional circumstances.

### 91283

#### Undergraduate Research Project

*8cp; 6hpw (average); prerequisites: completion of Stages 1–3*

This subject is an elective which should normally be taken during the final semester of study for the Environmental Biology or Environmental and Urban Horticulture degrees. The subject involves the planning, execution, analysis and reporting of a research project. Students work in small groups under the supervision of a member of academic staff, sharing acquired data but producing individual reports. This subject may involve compulsory field work. There is a formal lecture component dealing with research issues.

**91303****Experimental Design in Ecology**

*3cp; 3hpw; prerequisites: 91312 Biology 2; 91395 Biocomputing; 33106 Statistical Design and Analysis or equivalent*

The principles and practice of biological experimentation. The essential steps in experimental design and analysis, and their roles. The sources of experimental variability and the ways of effectively dealing with them. The logic of experimental and statistical hypothesis testing. The uses and limitations of these statistical tests in biology: multifactor analysis of variance, correlation, regression, chi square.

**91304****Honours (Biological and Biomedical Sciences)**

*2 semesters, 24cp per semester; prerequisite: BMedSc or BSc in Biomedical Science, Biotechnology, Environmental Biology, Environmental and Urban Horticulture or equivalent 3 yr degree*

Study designed to enhance the skills and knowledge necessary for research in the biological and biomedical sciences. The principal activity is an individual research project in which the student, under supervision, plans and undertakes investigations in an area of interest. The data collected are then subjected to analysis and interpretation under the guidance of the supervisor. Students learn to define objectives and aims, work to available time and resources, use appropriate research methods, critically assess information and develop complex arguments in detail. The findings of the research project are presented in a structured and integrated thesis which comprises the main assessment component.

**91305****Honours (Biological and Biomedical Sciences) (2yrs)**

*4 semesters, 12cp per semester; prerequisite: BMedSc or BSc in Biomedical Science, Biotechnology, Environmental Biology, Environmental and Urban Horticulture or equivalent 3 yr degree*

See 91304 above.

**91306****Terrestrial Ecosystems**

*4cp; 3hpw; prerequisites: 91309 Australian Biota; 91307 Community and Population Ecology; 91329 Ecological Sampling*

This subject provides an advanced understanding of the characteristics and functioning of terrestrial ecosystems and is designed to strengthen and develop skills in the acquisition and analysis of data from terrestrial systems. Patterns and processes in terrestrial ecosystems. The influence of soil, fire, climate and history on the characteristics of terrestrial environments. Causes and effects of degradation of terrestrial systems; management issues.

This subject includes a compulsory field excursion which may be conducted before commencement of semester.

**91307****Community and Population Ecology**

*3cp; 3hpw; prerequisites: 91312 Biology 2; 91395 Biocomputing*

This subject provides a foundation in the characteristics and functioning of populations and communities in terrestrial and aquatic ecosystems. It includes exploration of population and community processes, including inter- and intraspecific interactions and the origins of temporal and spatial patterns in communities and populations of plants and animals.

This subject may include a field excursion which could be conducted before commencement of semester.

**91308****Australian Soils**

*3cp; 3hpw; prerequisites: 65012 Chemistry 1A; 91311 Biology 1 or equivalent*

The formation of soil and its characteristics. Soil classification and distribution in Australia. The biota of Australian soils and their role in ecosystem function. Plant-soil interactions and the importance of soils in determining ecosystem composition and structure. Soil analytical techniques; quality assurance and control in soil analysis.

**91309****Australian Biota**

*6cp; 6hpw; prerequisite: 91312 Biology 2*

The principles and practice of taxonomy and evolutionary biology. The limitations and usefulness of taxonomic tools in botany and zoology. The major Australian groups of plants, vertebrates and invertebrates. The biogeography of Australian plants and vertebrates. The design and use of identification keys. Collection, identification and preservation of specimens from the field. This subject may include a field excursion.

**91311****Biology 1**

*6cp; 6hpw*

*This subject, together with 91312 Biology 2, constitutes a foundation course in biological sciences in the Faculty.*

Diversity of living organisms and their interaction with one another and the environment. Characteristics of living things; cellular basis of life; principles of classification; characteristics of kingdoms of living organisms and their sub-groups; genetics, evolution and natural selection; ecological principles, energy flow, nutrient cycles, community and ecosystems.

**91312****Biology 2**

*6cp; 6hpw; prerequisite: 91311 Biology 1 or equivalent*

Interrelationship between structure and function in living systems at two levels of organisation: cellular and organismic. Cell structure and physiology: molecular architecture of cells; cellular reactions and metabolism; molecular basis of heredity and information transfer. Animal physiology – mechanisms of movement, gas exchange and circulation, nutrition and digestion, osmoregulation and excretion among animal groups. Plant physiology – anatomy and physiology of flowering plants, nutrition, photosynthesis, transport. Physiological adaptations of Australian native species of animals and plants to the specific environments.

**91313****Biochemistry I**

*6cp; 6hpw; prerequisites: 91311 Biology 1; 65022 Chemistry 2A*

Bioenergetics and physical biochemistry: energy flow and transformation, laws of thermodynamics, free energy considerations in equilibrium and steady-state situations; electrolyte behaviour, pH and proton equilibria; colligative properties, osmotic pressure; chemical kinetics, catalysis and enzyme action. Structure and function of biological molecules emphasising structural, energy-providing and informational characteristics: carbohydrates, lipids, amino acids, peptides, proteins (including enzymes), nucleosides, nucleotides, nucleic acids. Replication and repair of DNA; recombinant DNA. Protein synthesis. Basic concepts of metabolic pathways; energetics of metabolism.

**91314****Microbiology I**

*6cp; 6hpw; prerequisite: 91702 Medical Science 2 or 91312 Biology 2*

An introduction to the structure, function and taxonomy of the bacteria, fungi, protozoa and viruses. Several key topics in the study of microbiology will be surveyed, including microscopy, microbial ecology, the microbe in its environment, microbial growth and physiology, pathogenesis, sterilisation and disinfection procedures, chemotherapy and laboratory techniques for safe handling of micro-organisms.

**91315****Biomonitoring**

*3cp; 3hpw; prerequisites: 91312 Biology 2; 91317 Human Biology or 91702 Medical Science 2; corequisite: 91314 Microbiology I*

The dynamics of natural and disturbed aquatic and terrestrial ecosystems; effects of industrial pollution on these ecosystems are investigated. Effects of pollution include chemical changes such as pH fluctuations, increases in concentrations of heavy metals and organic chemicals such as pesticides and detergents; biological contaminants resulting from sewage, garbage and changes in the balance of the natural micro-organisms' biota. Sampling procedures; estimates of biomass and productivity; methods of data analysis. This subject includes field excursions.

**91318****Ecological Modelling**

*4cp; 3hpw; prerequisite: 91307 Community and Population Ecology*

This subject provides an understanding of the importance and application of models in ecology. It includes an exploration of the different types of models used in modern ecological investigations and provides the necessary skills to evaluate their usefulness and limitations.

**91320****Biochemistry 2**

*6cp; 6hpw; prerequisite: 91313 Biochemistry 1*

Principles of catalysis. Purification properties and nomenclature of enzymes. Vitamins and enzyme cofactors. Localisation of enzymes. Regulation of enzyme action at cellular and molecular levels. Cellular role of ATP. Oxidative phosphorylation and the mitochondrion. The electron transport chain. Glucose catabolism and anabolism. The glycolytic sequence. The pentose phosphate pathway. The citric acid cycle. Fatty acid synthesis. Oxidation of fatty acids. Membrane models. Breakdown of proteins and metabolism of amino acids. One-carbon metabolism. Synthesis and degradation of nucleotides.

**91323****Mapping and Remote Sensing**

*4cp; 3hpw; prerequisites: 91395 Biocomputing; 91303 Experimental Design in Ecology; 91329 Ecological Sampling*

Vegetation and habitat mapping. Air photo interpretation of a defined area. Geographical Information Systems (GIS): design, interpretation and database construction. Applications of remote sensing, including aerial photographs and satellite data; image classification, rectification and spectral manipulation. Introduction to associated technologies such as Global Positioning Systems (GPS) and multispectral scanning.

This subject may involve an intensive practical session during a non-teaching week.

**91324****Environmental Toxicology**

*8cp; 6hpw; prerequisites: 91303 Experimental Design in Ecology; 91329 Ecological Sampling*

Biological and chemical principles of pest control: the safe use of pesticides. Methods of toxicological testing for pesticides, heavy metals and other hazardous chemicals, in air, soil and water, using biological assays of animals and plants.

**91325****Principles and Practice of Biotechnology**

*3cp; 3hpw; prerequisites: 91313 Biochemistry 1; 91314 Microbiology 1*

This subject provides an overview of the business of biotechnology including the financing, establishment and management of biotechnology companies and the legislation and regulation (patents, intellectual property, biosafety) of biotechnology. The underlying technologies and economics as exemplified by molecular biology, protein engineering, fermentation technology, processing and quality control are considered and specific examples of biotechnology industries are examined with an emphasis on the Australian perspective.

**91326****Analytical Biochemistry**

*6cp; 6hpw; prerequisite: 91313 Biochemistry 1*

Modern analytical methods in biochemistry with emphasis on instrumentation and underlying principles. Qualitative biochemical analysis. Spectroscopic methods (spectrophotometry, spectrofluorometry, flame emission and absorption photometry, magnetic resonance methods). Separation methods (chromatography, electrophoresis, centrifugation). Electrochemical methods (potentiometry and ion electrodes, polarography). Introduction to radiochemistry. Errors in analysis. Immunoassay methods. Implications of biochemical equilibria in analysis. Molecular biology techniques.

**91327****Environmental Management Procedures**

*4cp; 3hpw; prerequisites: completion of Stages 1–4*

Environmental legislation of NSW and Australia and their associated regulations. Socioeconomic factors in environmental



decision making and management. Environmental impact assessment and planning processes. Application of environmental quality criteria in pollution control. Economic and other instruments in environmental management. The application of scientific methods and data in environmental protection and management.

### 91328

#### Environmental Microbiology

*4cp; 3hpw; prerequisite: 91314 Microbiology 1*

Nature of micro-organisms. Factors affecting occurrence and growth of micro-organisms. Kinetics and measurement of microbial growth. Ecology of microbial populations and communities. Microbial activities in natural ecosystems. Utilisation of microbial activities in bioremediation and environmental management.

### 91329

#### Ecological Sampling

*3cp; 3hpw; prerequisites: 91312 Biology 2; 33105 Introductory Biometrics or equivalent; 91395 Biocomputing*

Measurement and analysis as part of the resource management process. Techniques for estimating the abundance of sedentary and mobile organisms. Techniques for biomass and productivity estimation. Ecological sampling procedures and designs. Techniques for analysing univariate and multivariate data. This subject may include a field excursion.

### 91330

#### Microbiology 2

*6cp; 6hpw; prerequisite: 91314 Microbiology 1*

Microbial physiology and basic applied microbiology. Bacterial physiology – nutrition, energetics; biosynthesis and growth. Mechanisms and use of growth and physiological reactions in diagnostic and applied microbiology. Features of, and factors influencing, the microbial flora of habitats such as the higher animal body, soils, water supply and disposal systems and foods. The survival, growth and death of such flora; methods for identification and quantitation. Introduction to bacterial genetic systems and processes. Anti-microbial substances in the environmental, hospital and laboratory environments.

### 91331

#### Microbiology 3

*8cp; 6hpw; prerequisite: 91330 Microbiology 2*

Public health microbiology. Basic epidemiological principles; mathematical formulation of epidemics; sociological aspects. The public health laboratory environment; food, water and airborne diseases; exotic and notifiable diseases; zoonoses. Epidemiological tracing methods; biotyping; serotyping; bacteriophage typing; bacteriocin (BLIS) typing; molecular typing. Control measures; hygiene; sanitation; disinfection; sterilisation; vaccines, vaccination procedures and vaccination programs.

### 91332

#### Molecular Biology I

*8cp; 6hpw; prerequisites: 91314 Microbiology 1; 91313 Biochemistry 1*

Introduction to the basis of present-day molecular biology. Key concepts and procedures in bacterial and bacteriophage genetics, including mutation, recombination and mechanisms of genetic exchange, utilising plasmids, transposons and viruses. Introduction to the principles and procedures underlying DNA manipulation methods in the molecular biology laboratory, including the molecular cloning, selection and analysis of recombinant DNA.

### 91333

#### Introductory Marine Ecology

*8cp; 7 days block mode; prerequisite: completion of stages 1–4*

This subject builds upon the basic ecological principles students have gained from other subjects throughout the course. As such it applies those principles to the practical study of issues in a marine and estuarine environment with real hands-on experience. The subject draws upon the academic experience of staff from other institutions as well as UTS to provide material covering a range of aspects concerning the marine environment including chemical, biological, geological and physical oceanography, in addition to the biology of fishes, benthic fauna, plants and sediments. Lectures are complemented by an extensive field program, and assessment is gained by final written exam, seminar and a project report, which is submitted after the excursion.

**91335****Molecular Biology 2**

*8cp; 6hpw; prerequisite: 91332 Molecular Biology 1*

Structure and organisation of the eukaryotic genome. Control of genome expression by regulation of RNA synthesis, processing and translation. Development and differentiation. Techniques and application of hybridisation, sequencing, polymerase chain reactions and Western blotting. Preparation of DNA libraries. Clinical applications of molecular biology in inherited disease detection and infectious disease diagnosis.

**91338****Clinical Bacteriology**

*8cp; 6hpw; prerequisite: 91331 Microbiology 3*

Quantitative methods, reliability studies, automation, data processing and numerical analysis in clinical microbiology. Pathogenic micro-organisms: their handling (including safety requirements), cultivation, isolation and relationship to the indigenous flora of humans and animals. A detailed study of staphylococci, streptococci, coryne-bacteria, mycobacteria, neisseria, enteric bacteria, pasteuriae, pseudomonads and spirochaetes. Antibiotics and antibiotic sensitivity testing.

**91340****Transfusion Science**

*8cp; 6hpw; prerequisites: 91354 Anatomical Pathology; 91355 Haematology 1; 91351 Immunology 1*

This subject covers the following topics: human blood groups; principles of donor blood compatibility and antigen/antibody reactions; detection and identification of serum antibodies; blood products; the safety of the blood supply and minimisation of transmission of infectious diseases; investigation of transfusion reactions; haemolytic disease of the newborn; blood groups in forensic investigations; platelet and leucocyte immunohaematology; transfusion in critical care situations; legal aspects of transfusion of blood products; stem cell transplantation; and cytokine stimulation of haemopoiesis.

**91344****Clinical Biochemistry 1**

*8cp; 6hpw; prerequisite: 91320 Biochemistry 2*

Principles of clinical biochemistry. Laboratory hazards and quality control including appropriate statistics as used in clinical biochemical laboratories. Introduction to calculations and analyses of clinically important substances. Pre-analytical procedures. Qualitative analysis as exemplified by urine analysis. Quantitative analysis as exemplified by inorganic phosphorus analysis. Spectroscopic identification of normal and abnormal haemoglobin pigments. Blood sugar estimations and basis of abnormalities of carbohydrate metabolism. Principles of clinical enzymology with particular reference to the methodology. Principle of automation involving discrete and continuous flow methods.

**91345****Clinical Biochemistry 2**

*8cp; 6hpw; prerequisite: 91344 Clinical Biochemistry 1*

Measurements of homeostasis and its malfunction. Liver and kidney function and disorders. Regulation of electrolyte, water and acid-base balance. Serum protein patterns in health and disease. Abnormalities of lipid metabolism. Radio immunoassay, hormone evaluation with special emphasis on thyroid function, isoenzymes, malabsorption syndromes, vitamin levels in clinical investigation.

**91347****Toxic Materials in the Environment**

*4cp; 3hpw; prerequisites: completion of Stages 1–4*

Pathways of toxic substances in the environment. Transfer mechanisms between the different environment compartments. Bioaccumulation and biotransformation. Environmental legislation: the NSW Environmental Acts and their associated regulations; comparison of the Federal Acts with those from other States; significance of socioeconomic factors on decision making in environmental impact assessment; objectives, contents and procedures for the preparation of environmental impact statements.

**91351****Immunology I**

*3cp; 3hpw; prerequisites: 91354 Anatomical Pathology; 91314 Microbiology I or 91313 Biochemistry I*

This subject is designed to introduce the basic concepts of immunology. It is structured in such a way that it follows the course of an immune response, from initial non-specific reactions to the development of adaptive responses and immunological memory. Emphasis is given to the basic concepts that underlie the recognition of foreignness and the response to infection. The practical sessions introduce students to a variety of cellular and serological techniques that are the cornerstones of immunological analysis. In addition, special interactive teaching sessions are used to explore contemporary topics in immunology.

**91352****Eukaryotic Microbiology**

*8cp; 6hpw; prerequisites: 91314 Microbiology I; 91332 Molecular Biology I; 91351 Immunology I*

This subject covers the following topics: parasitism; biology of parasitic worms including nematodes, trematodes and cestodes; biology of parasitic protozoa including the sporozoans, flagellates, amoeba and ciliates; arthropods as vectors of disease; clinical parasitology; molecular biology of parasites; immunity and vaccine development; biology of fungi; fungal pathogenicity and infection; antiparasitic and antifungal therapy; and biotechnological applications of fungi.

**91354****Anatomical Pathology**

*6cp; 6hpw; prerequisites: 91312 Biology 2; 91702 Medical Science 2 or 91317 Human Biology; 65022 Chemistry 2A*

This subject provides a basic knowledge of disease processes, the body's responses to them, the preparation and staining of mammalian tissues for microscopic examination of organ structure, and light microscopic appearance of diseased tissues.

The subject also introduces the chemistry of biological dyes and their uses in the laboratory to highlight normal tissue structures and to demonstrate pathological tissue changes that occur during disease development.

This is all integrated to present an understanding of disease with its morphological appearance and the laboratory techniques

used to interpret structural tissue changes that occur in disease states.

**91355****Haematology I**

*3cp; 3hpw; prerequisites: 91354 Anatomical Pathology; 91314 Microbiology I or 91313 Biochemistry I*

Structure, function and morphology of normal blood and bone marrow. Haemostasis and haematopoiesis. Automated laboratory equipment used in haematology. Introduction to haematological disease and the significance of haematological changes in disease.

**91358****Haematology 2**

*8cp; 6hpw; prerequisite: 91355 Haematology I*

Disease processes related to hereditary, acquired, benign and malignant disorders of haematological systems. Correlation of physiological processes, pathological states and diagnostic tools in haematology. Light microscopic morphological examination of peripheral blood and bone marrow in disease and correlation of these findings with indices and cell counts obtained by automated laboratory equipment. Procedures for detection and precise diagnosis of anaemias, haemostatic disorders, haemoglobin disorders and haematological malignancies. Introduction to cytogenetics; prenatal diagnosis of genetic disease; genetic counselling and cancer cytogenetics.

**91359****Immunology 2**

*8cp; 6hpw; prerequisite: 91351 Immunology I*

Provides current concepts of modern immunology to students who have some basic understanding of the subject, and an appreciation of the wide spectrum of applied immunology in medicine, research and industry. Specialised areas of immunology covered include genetics of antibody diversity; structure of antibodies, T-cell receptor and MHC molecules; cytokines; monoclonal antibodies; clinical immunology and techniques applicable in both diagnostic and research laboratories including enzyme-linked immunoassays; cell separations and flow cytometry.

**91363****Animal Ecophysiology***6cp; 6hpw; prerequisite: 91309 Australian Biota*

Basic concepts in ecophysiology; limiting factors, lethal limits, acclimation. Patterns of physiological responses to natural and selected manufactured stressors. Coordination of physiological processes with environmental factors; neuro-endocrine control of life cycles and physiological responses, stress syndrome. Population changes; basic animal population dynamics, structure, growth and regulation of populations. This subject includes a field excursion.

**91364****Aquatic Ecology***8cp; 6hpw; prerequisites: 91362 Plant Ecophysiology or equivalent; 91363 Animal Ecophysiology*

Australian water resources and the hydrological cycle. Structural components and functional processes of aquatic ecosystems; physical, chemical and biological features; energy flows and nutrient cycles. Distinctive features of lakes, rivers and streams, estuaries, coastal lagoons and the sea. Assessment and monitoring of water pollution problems; water quality and biological surveillance. Management of polluted and disturbed aquatic habitats. Management of water supply reservoirs. This subject will involve a number of field excursions including an excursion in February preceding enrolment.

**91368****Bioprocessing***8cp; 6hpw; prerequisite: 91330 Microbiology 2*

Fermentation technology; processes of formation and extraction of useful products of microbial, animal and plant cells; the microbiological, physiological and biochemical bases of industrially useful fermentations in the food, beverage, pharmaceutical and other relevant industries; unit operations and processing procedures in industrial fermentations. Computer interfacing and control procedures for fermentation systems. Economic and other factors impinging on the operation of fermentation industries. Industrial visits and a literature project are undertaken in this subject.

**91369****Applied and Environmental Microbiology***8cp; 6hpw; prerequisite: 91330 Microbiology 2*

Foods and waters as microbial ecosystems. Factors affecting their contamination by microorganisms of spoilage and public health significance. Indicator organisms and the microbiological monitoring of foods and waters. Quality control in food production and water management. Waste treatment processes for industrial and domestic wastes. Bioremediation of contaminated aquatic and terrestrial ecosystems.

Industrial visits are an important component of this subject.

**91370****Field Studies: Semiarid Ecology***8cp; 6hpw (run over 10–14 day excursion to far-western NSW in July every third year, alternating with 91371 i.e. a major field elective every 18 months)*

This and other electives are normally taken in senior stages of the degree course. It can thus be assumed that students will have a thorough knowledge of basic ecology (see also elective field study subjects 91371 and 91375). The aim of the subject is to broaden students' understanding of environmental biology and its management applications by demonstration and experimentation outside the Sydney Basin. The importance of water and water management, rangeland management and national parks management of dry areas will be included, along with ecological studies of factors determining the composition and structure of semiarid vegetation. Assessment will involve submission of a log book/journal and a project report or presentation, to be completed after the field excursion.

**91371****Field Studies: Mountain Ecology***8cp; 6hpw (run over 10-day excursion to south-eastern NSW in December every third year, alternating with 91370 i.e. a major field elective every 18 months)*

This and other electives are normally taken in senior stages of the degree course. It can thus be assumed that students will have a thorough knowledge of basic ecology (see also elective field study subjects 91370 and 91375). The aim of the subject is to broaden the student's understanding of environmental biology and

its management applications by demonstration and experimentation outside the Sydney Basin. The student will be introduced by demonstration and experimentation to the ecology of tall forests and mountain areas, the management of mountain forests, the impacts of forestry operations, and the management of national parks and wilderness areas. Assessment will involve submission of a log book/journal, and a project report or presentation, to be completed after the field excursion.

### 91375

#### Field Studies: Marine Sciences

*4cp; 3hpw; (run over 6-day excursion to Jervis Bay or similar south coast area of NSW, currently offered twice each year in January/February and July)*

This and other electives are normally taken in senior stages of the degree course. It can thus be assumed that students will have a thorough knowledge of basic ecology (see also elective field study subjects 91370 and 91371). The aim of the subject is to broaden the student's understanding of environmental biology and its management applications by demonstration and experimentation outside the Sydney Basin. The student will be introduced by demonstration and experimentation to a variety of marine, estuarine, and littoral ecosystems, and the management principles and practices in each zone.

This excursion is seen as part of the interinstitutional field studies series of the Australian Marine Sciences Consortium (AMSC) which includes 20 member universities in Australia and New Zealand, the Australian Institute of Marine Science, the Australian Defence Force Academy, and the Royal Australian Naval College. Instructors in a range of relevant disciplines come from member institutions, and investigations include chemical, biological, geological and physical oceanography, in addition to the biology of fishes, benthic fauna, plants and sediments.

In accordance with the guidelines for AMSC excursions, UTS supervisors will assess a report submitted on the final day of the field trip.

### 91376

#### Environmental Measurement

*3cp; 3hpw; prerequisites: 91312 Biology 2; 33105 Introductory Biometrics or equivalent; 91395 Biocomputing*

Measurement and analysis as part of the resource management process. Techniques of estimating population size and density of sedentary organisms; sampling methods, assessments and data analysis in aquatic and terrestrial systems. Techniques for sampling multispecies communities and mobile organisms. Estimations of biomass and productivity. This subject involves an excursion to develop skills of field identification of organisms and measurement techniques, aquatic and terrestrial.

### 91377

#### Cytopathology

*16cp; 6hpw, for 2 semesters; prerequisites: 91354 Anatomical Pathology; 91355 Haematology I*

Instruction in the interpretation and diagnosis, at the light microscope level, of cell samples from a variety of anatomical sites. Morphologic features of cells in normal states, effects of inflammation, physiologic patterns, hormonal effects, changes due to specific organisms and viruses, premalignant and malignant conditions and the effects of treatments on cell morphology and smear patterns. Instruction on cell samples from the female genital tract, respiratory tract, alimentary tract, urinary tract, serous cavities, central nervous system, breast and thyroid with emphasis on fine needle aspiration samples. Principles and procedures of specimen collection, preparation and staining, reporting methodology and laboratory procedures are covered. Epidemiologic and aetiologic factors in premalignant and malignant diseases and special procedures which complement cytopathologic diagnosis are included.

### 91382

#### Introduction to Biological Fluids

*3cp; 2hpw; prerequisites: 65401 Analytical Chemistry I (old); 65557 Forensic Toxicology I (old); corequisite: 65657 Forensic Toxicology 2 (old)*

This subject introduces the nature of biological fluids, their chemical composition, the biochemistry of their important components, and their value and relevance in forensic evidence gathering. Different methods for the identification of various biological fluid components will be examined along with the

techniques which are used to identify, classify and differentiate the individual people from whom the fluids were collected or from whom they may have been derived. Levels of probability of the sample coming from a given individual will be considered, with discourse about levels of certainty and use of population statistics.

### 91395

#### **Biocomputing**

*3cp; 3hpw*

Introduction to computers and programs in the biological sciences. Analysis of the operation of computer systems with emphasis on principles of hardware architecture, operating systems, editors and file management. Comparison of various types of computers, IBM PC, Macintosh, mainframe, and various software packages available for the biological and biomedical sciences.

### 91398

#### **Special Reading Assignment – Life Sciences**

*4cp*

To be undertaken only following prior negotiation on the part of the student with a full-time member of academic staff regarding individual supervision. In addition, requires special permission of the Associate Dean.

### 91399

#### **Individual Project – Life Sciences**

*8cp*

To be undertaken only following prior negotiation on the part of the student with a full-time member of academic staff regarding individual supervision. In addition, requires special permission of the Associate Dean.

### 91410

#### **Principles of Clinical Biochemistry**

*8cp; 5hpw*

Introduction to core concepts in clinical biochemistry and their practical implementation. Laboratory hazards. Appropriate statistical methods for quality control of laboratory results; reference intervals; diagnostic sensitivity and specificity. Pre-analytical procedures. Quantitative analysis as exemplified by urine analysis, serum anions and cations and the spectroscopic identification of normal and abnormal haemoglobin pigments. Blood sugar

estimations and abnormalities of carbohydrate metabolism. Principles of clinical enzymology with particular reference to the steps required for method optimisation. Serum proteins as an aid to the diagnosis and monitoring of disease. Liver function testing. Principles of automation. Introduction to the clinical biochemistry literature.

### 91411

#### **Biochemical Pathophysiology**

*8cp; 5hpw*

Role of the clinical biochemistry laboratory in patient care with emphasis on the biochemical indications of underlying pathology. Measurement of homeostasis and its malfunction, as seen in regulation of acid-base balance, and kidney function. Purine metabolism and uric acid. Abnormalities of lipid metabolism. Introductory endocrinology, including the hypothalamic-pituitary axis and adrenal and thyroid function testing. Radioimmunoassay and related techniques and their role in hormonal evaluation with special emphasis on thyroid function. Gastrointestinal disorders and malabsorption syndromes. Introduction to applications of recombinant DNA techniques in clinical biochemistry. Laboratory-based project to evaluate two alternative methods of estimating a given biochemical analyte in a biological fluid.

### 91412

#### **Biomedical Sciences 1**

*10cp; 6hpw*

This subject may be undertaken only with special permission of the Course Coordinator, Clinical Biochemistry.

### 91413

#### **Biomedical Sciences 2**

*10cp; 6hpw*

This subject may be undertaken only with special permission of the Course Coordinator, Clinical Biochemistry.

### 91414

#### **Analytical Biochemistry Project 1**

*5cp; 3hpw*

This subject may be undertaken only with special permission of the Course Coordinator, Clinical Biochemistry.

**91415****Analytical Biochemistry Project 2***6cp; 3hpw*

This subject may be undertaken only with special permission of the Course Coordinator, Clinical Biochemistry.

**91417****Clinical Laboratory Management***4cp; 3hpw; prerequisite: 91410 Principles of Clinical Biochemistry*

Organising, operating, staffing and controlling the clinical diagnostic laboratory. Procedure and equipment evaluation; reporting and accreditation. A perspective of accounting and financial control; legal and ethical considerations and constraints.

**91419****Case Studies in Clinical Biochemistry***8cp; 3hpw; prerequisite: 91411 Biochemical Pathophysiology*

Interactive discussion of a variety of case studies derived from different areas of clinical biochemistry, illustrating significance of laboratory quality control, metabolic interrelationships, and the necessity for considering a patient's complete case history in order to gain a true perspective.

**91426****Analytical Techniques in Clinical Biochemistry***8cp; 5hpw*

Survey of modern techniques for analysis of biochemical samples, emphasising instrumentation, underlying principles and critical evaluation. Spectroscopic methods: spectrophotometry, spectrofluorimetry, atomic emission and absorption photometry, mass spectrometry, electron paramagnetic resonance, nuclear magnetic resonance. Separation methods: chromatography, electrophoresis, centrifugation. Electrochemical methods: potentiometry and ion-selective electrodes, polarography. Biosensors. Immunoassay strategies. Introduction to radiochemical tracers. Molecular biology techniques: DNA analysis and gene probes. Errors in analysis. Implications of biochemical equilibria and kinetics in terminal and fixed point analysis.

**91440****Experimental Design and Methods***4cp; 3hpw*

Logic of scientific experiments; elements of experimental design; sampling strategies and data collection; data analysis. Construction and interpretation of statistical models; multivariate pattern analysis. Experimental design considerations for impacted sites.

**91454****Diagnostic Bacteriology***8cp; 6hpw*

Quantitative methods, reliability studies, automation, data processing and numerical analysis in clinical microbiology. Pathogenic microorganisms: their handling (including safety requirements), cultivation, isolation and relationship to the indigenous flora of humans and animals. A detailed study of the staphylococci, streptococci, corynebacteria, mycobacteria, neisseria, enteric bacteria, pasteurellae, pseudomonads, aeromonads, vibrios and spirochaetes. Antibiotics and antibiotic sensitivity testing; resistance mechanisms. Pathogens of veterinary significance. Molecular techniques for diagnosis and identification.

**91455****Human Parasitology and Mycology***8cp; 6hpw*

Parasitism. Biology of parasitic worms including nematodes, trematodes and cestodes. Biology of parasitic protozoa including the sporozoans, flagellates, amoeba and ciliates. Arthropods as vectors of disease. Clinical parasitology. Molecular biology of parasites. Immunity and vaccine development. Biology of fungi. Fungal pathogenicity and infection. Antiparasitic and antifungal therapy. Biotechnological applications of fungi.

**91457****Immunological Responses to Infection***4cp; 3hpw*

The structure of the subject essentially follows the course of the body's immune reaction to infection, from initial non-specific events to adaptive responses and immunological memory. The concepts of foreignness recognition and infection response are stressed. Practical sessions give students insight into the serological and cellular methods that underlie

serological analysis. Contemporary immunological issues are explored in interactive teaching sessions.

### 91458

#### Individual Research Project – Clinical Biochemistry – P/T

24cp; 2 semesters

This investigative study component of the Master of Science (Honours) in Clinical Biochemistry extends over two semesters which should preferably be consecutive. Students are expected to formulate a written proposal which nominates the topic of the study. The study will normally consist of a laboratory-based investigation, but may also be an investigation of an epidemiological problem, of quality assurance, or of management in the clinical biochemistry laboratory. It may also be an extensive study based on published sources. The topic of the study should relate to current problems or developments in the field of clinical biochemistry practice. The project will be completed in accordance with Science Faculty rules for Master's degrees by coursework.

### 91466

#### Individual Research Project – Clinical Biochemistry – F/T

24cp

This investigative study component of the Master of Science (Honours) in Clinical Biochemistry extends over one semester. Students are expected to formulate a written proposal which nominates the topic of the study. The study will normally consist of a laboratory-based investigation, but may also be an investigation of an epidemiological problem, of quality assurance, or of management in the clinical biochemistry laboratory. It may also be an extensive study based on published sources. The topic of the study should relate to current problems or developments in the field of clinical biochemistry practice. The project will be completed in accordance with Science Faculty rules for Master's degrees by coursework.

### 91467

#### Clinical Biochemistry – Advanced Aspects

8cp; 5hpw; prerequisite: 91410 Principles of Clinical Biochemistry; corequisite 91411 Biochemical Pathophysiology

Specialised aspects of clinical biochemistry. Primary and secondary liver diseases. Biochemical detection of acute myocardial infarction. Metabolism of catecholamine and detection of phaeochromocytomas. Biochemistry of porphyrins and screening tests for porphyria. Foeto-placental function tests. Immunological methods. Toxicology and drug metabolism: modern methods for screening, identification and quantification of drugs of abuse. Approved protocols for the evaluation of instruments. Inborn errors of metabolism. Immunoassay design. Disorders of the adrenal gland.

### 91468

#### Introduction to Ecotoxicology

8cp; 6hpw

Basic principles of ecotoxicology; ecological systems and processes; overview of current environmental issues. Classes of toxic substances in the environment, their sources, chemistry and effects on biota at various levels of organism, community, population and ecosystem. Toxicity testing as a tool for assessing toxic effects of chemicals on biota. Acute and chronic tests, test design, selection of test organisms, test protocols, outcomes and limitations, with examples of standard tests using plants and animals. Microcosms, mesocosms.

### 91469

#### Laboratory Methods in Ecotoxicology

12cp; 9hpw

Application of analytical laboratory techniques in determining ecotoxicological responses at cellular and subcellular level. Biochemical mechanisms involved in entry, transformation and removal of toxic substances in plants, animals and microorganisms. Physiological and cellular responses to toxicants, biomarkers, applications of molecular biology in ecotoxicology. Environmental toxicology of mammalian systems – toxicokinetics, target organ toxicity, teratology, mutagenesis, carcinogenesis.



**91470****Field Methods in Ecotoxicology***8cp; 6hpw*

Physicochemical behaviour of pollutants in the environments. Impact of toxic chemicals on communities and populations; interactive effects of pollutants; bioaccumulation and biotransformation. Sampling methods for biomonitoring of soils, air, plants and animals; quality control in sampling. Biological indices and biomarkers suitable for field testing.

**91474****Statistics in Bioscience***4cp; 3hpw*

Review of parametric and non-parametric statistics; population distributions, tests of significance, selection of suitable statistical tests; analysis of variance, correlation and regression analysis; distribution free tests, probit analysis. Use of major computer packages (SPSS, Minitab) for statistics.

**91478****Economics of Coastal Resources***4cp; 3hpw*

Concentrates on the fundamental economic principles that underlie the allocation of coastal resources. The concept of ecologically sustainable development will be considered within an economic framework, and its significance to coastal resources will be assessed. Case studies and applications of environmental economic techniques to coastal resource management problems will be investigated.

**91479****Coastal Zone Law***4cp; 3hpw*

A survey will be made of those areas of law that are designed to control or regulate environmental quality of coastal resources. The subject covers the common law heritage and the major statutory and common law controls over pollution, use of land, terrestrial, aquatic, and heritage resources. The emphasis will be on Australian legislation in comparison with that of other countries.

**91480****Epidemiology and Disease Control***4cp; 3hpw*

Public health microbiology. Basic epidemiological principles; mathematical formulation of epidemics; sociological aspects. Randomised control (double-bind) trials, cohort and case-control studies, descriptive and descriptive-analytical surveys. Prevention and control measures (antibiotics, vaccines, vaccination procedures and vaccination programs) and their success as judged by the various trials and surveys performed.

**91481****Current Topics in Clinical Microbiology***4cp; 2hpw*

Classes in this subject will be wide ranging in the field of medical microbiology and will be presented by staff from UTS and invited guest lecturers. A survey of selected topics in clinical microbiology will be undertaken, but the precise mix of topics will vary from year to year. A range of current problems, and recent developments, will be presented.

**91487****Research Methodology – Medical Microbiology***3cp; 2hpw*

Overview of approaches to research; defining the problem, planning the experimental work; interpretation of laboratory data; critical review of published work.

**91488****Molecular Microbiology***8cp; 2hpw lectures plus total of 40 hrs of laboratory work/visits during semester*

Key concepts and procedures in molecular biology, including bacterial and bacteriophage genetics, mutation and DNA exchange. Plasmids, transposons and other mobilisable genetic elements. DNA isolation, manipulation and cloning procedures. Applications of molecular biology in the diagnostic laboratory for organism identification and characterisation.

**91491****Research Project – Medical Microbiology P/T***24cp; 2 semesters*

An individual research project in an area of specific interest or a work-related topic. The project topic will be developed in advance in consultation with the Course Coordinator and other academic staff involved in the teaching of the Master's degree program.

**91492****Research Project – Medical Microbiology F/T***24cp; 1 semester*

As for 91491 Research Project – Medical Microbiology P/T.

**91493****Biosystems***4cp; 3hpw*

Characteristics of living things; classification of organisms; cell structure and function; genetics and evolution. Ecological concepts; interaction of organisms, communities, populations. Animal and plant responses to natural and human-induced stresses in aquatic and terrestrial environments.

**91494****Ecosystem Assessment***6cp; 5hpw*

Principles of environmental monitoring; natural and stress-imposed variability in ecosystems; spatial and temporal variability; demographic parameters. Toxicity data from bioassay, field and toxicity tests as a basis for environmental quality guidelines and for bioremediation procedures.

**91495****Environmental Risk Assessment and Management***6cp; 5hpw*

Environmental legislation and regulation at State and federal level, international environmental conventions; environmental management issues; significance of socioeconomic factors on decision making in environmental matters; environmental impact assessment – objectives, contents and procedures; risk assessment procedures, ERA, application of Australian/New Zealand Standard on risk management; requirement for

Australian state of environment reporting; hazard assessment and contaminated sites; remediation, disposal, minimisation.

**91496****Ecotoxicology Project (P/T)**

*24cp, over two semesters; equivalent to 91475 Environmental Toxicology Project P/T and 91476 Environmental Toxicology Project F/T; prerequisites include all the coursework subjects in Master of Science in Ecotoxicology, generally at a credit level.*

Project may take the form of experimental investigations, design studies, extensive critical reviews or other suitable activities. Projects can be carried out at the student's workplace, after obtaining the necessary approvals, so that candidates have some introduction to professional practice. In that case, a member of academic staff at UTS will be appointed as internal supervisor, while a co-supervisor may be appointed from that laboratory. In some cases, if a suitable project can be identified, international or interstate students can return to their normal workplace to carry out the project. All projects will be completed in accordance with the rules for Master's degrees by coursework.

**91497****Ecotoxicology Project (F/T)**

*24cp, equivalent to 91475 Environmental Toxicology Project P/T and 91476 Environmental Toxicology Project F/T; prerequisites include all the coursework subjects in Master of Science in Ecotoxicology, generally at a credit level.*

As for 91496 Ecotoxicology Project (P/T).

**91498****Special Reading Assignment P/G – Life Sciences***6cp*

This reading assignment can be undertaken only following negotiation by the student with a full-time member of academic staff to gain agreement to be individually supervised. It also requires special permission of the appropriate Subject Coordinator and Associate Dean.

**91499****Individual Project P/G – Life Sciences***10cp*

This individual project can be undertaken only following negotiation by the student with a full-time member of academic staff to gain

agreement to be individually supervised. It also requires special permission of the appropriate Subject Coordinator and Associate Dean.

### 91607

#### Research Methods 1

4cp; 4hpw

This subject is an introduction to the scientific method and its importance to the acupuncture profession. It deals with basic research issues: theories and models; independent, dependent and confounding variables; and the influence of the placebo effect. It also examines the philosophical basis of positivist, empiricist and analytical approaches to scientific endeavours.

### 91608

#### Research Methods 2

4cp; 4hpw; prerequisite: 91607 Research Methods 1

This subject builds on material provided in Research Methods 1. It provides the student with a solid grasp of the research process in health sciences and encourages research into acupuncture. As such, it is an important foundation for students in undertaking an independent research project.

### 91609

#### Biomedical Science Upgrade

8cp; 4hpw

This subject is designed for practising acupuncturists with a background of training in the biomedical sciences. The aim of the course is to consolidate existing knowledge and extend it in areas particularly relevant to acupuncture such as neuroscience, pathophysiology and microbiology.

### 91651

#### Environmental Microbiology for Engineers

prerequisite: 91650 Introduction to Environmental Biology

This subject is only available to students enrolled in an undergraduate degree in the Faculty of Engineering. The subject introduces students to the nature of living organisms classified as microorganisms and the significance of microbial activities for engineering or processes involving environmental impacts. The subject provides an overview of the growth characteristics of microorganism and the environmental factors

which influence their growth. Microorganisms are dealt with in the context of decomposition processes, transformations of chemicals in biogeochemical cycles, as potential pathogens in water and groundwaters, in wastewater treatment, corrosion processes and public health. Their potential uses in bio-remediation and bio-reclamation are also discussed.

### 91701

#### Medical Science 1

6cp; 6hpw

This subject provides an introduction to the anatomy and physiology of the healthy human body. Lectures are complemented by an appropriate practical program. The content includes: the levels of organisation in the body; basic anatomy, anatomical terms, surface anatomy and body regions and overview of major organ systems. Transport of materials across membranes, osmosis diffusion, active transport. The basic concepts of microscopy and the histology of tissues and major organ systems. The general structure and functional significance of the major organ systems. Basic microbiology and aseptic technique. The basic concepts of modern genetics. Chromosomes, mitosis and meiosis, DNA, RNA, transcription, translation. Mutations and oncogenes. Genetic inheritance, disorders and pedigrees. The structure, function and histology of the integumentary system, the musculoskeletal system, the gastrointestinal system, cardiovascular, lymphatic and renal systems. The chemical principles related to enzyme action and kinetics and the chemical reactions in digestion.

### 91702

#### Medical Science 2

6cp; 6hpw; prerequisite: 91701 Medical Science 1

This subject completes the coverage of the anatomy and physiology of the body systems begun in Medical Science 1. It is also designed to foster an appreciation of the interactions between and control of all body systems. Independent learning as well as critical analysis and communication skills will also be developed in this unit. Topics include: structure and function of the respiratory, endocrine, nervous, reproductive and immune systems along with relevant clinical applications in each system.

**91703****Physiological Systems**

*6cp; 5hpw; prerequisite: 91702 Medical Science 2*

This subject extends the knowledge and understanding of cellular elements of the body and of certain body organ systems that were introduced in the subjects Medical Science 1 and 2. It provides an understanding of control systems, principles of mass transfer and compartmental systems analysis and how these principles apply to the body. Ion channels and membrane transport processes. Circulation and cardiovascular system. Control of metabolism and endocrine system. Formation and excretion of urine. Regulation of extracellular fluid composition and volume. Lecture material complemented by practicals, tutorials and directed self-study modules.

**91704****Behavioural Sciences**

*6cp; 4hpw; prerequisites: 33105 Introductory Biometrics or equivalent; 91703 Physiological Systems*

The overall aim of this study is to demonstrate the significance of contributions of theories and practices from the behavioural sciences to effective medical theory and practice. Key concepts, principles and theories from the behavioural sciences that have particular relevance to the medical sciences are explored within the framework of selected health care and medical scenarios such as chronic pain, the placebo effect, depression, cardiovascular disease, health promotion. Content provides an introduction to the field of behavioural medicine which addresses the application of theory and practice of the behavioural sciences to the theory and practice of modern medicine. Students have practical experience in the application of principles from cognitive learning theory in design and completion of behavioural monitoring and self-management programs.

**91705****Medical Devices and Diagnostics**

*6cp; 6hpw; prerequisites: 68201 Physics 2; 91703 Physiological Systems*

This subject provides an introduction to the principles of operation and use of typical devices encountered in medical practice. Specific emphasis is given to various methods of transducing information from the body such as pressure, internal voltage signals,

oximetry temperature. Principles of active stimulation of various organs such as heart, muscle and cochlear are also taught. Medical overview of the regulatory framework imaging modalities explored is also given.

**91706****Neuroscience**

*8cp; 6hpw; prerequisite: 91703 Physiological Systems; corequisite: 91707 Pharmacology I*

This subject provides an advanced understanding of the physiological basis of the nervous system. Physiology of excitable tissue. Structure, function and control of ion channels. Functions of the nervous system, with special reference to systems including complex reflex systems, control of posture and movement, cutaneous, deep and visceral sensation, central regulation of visceral function, vision, hearing and equilibrium, smell and taste, arousal mechanisms, sleep and electrical activity of the brain, autonomic nervous system, neural basis of instinctual behaviour and emotions. Higher functions of the nervous system. Neural nets and cybernetics. Case studies of disease states in the nervous system. Lecture material is complemented by practicals, tutorials and self-directed study modules. Emphasis on student presentation of case studies and seminars.

**91707****Pharmacology I**

*8cp; 6hpw (average); prerequisites: 91320 Biochemistry 2; 91703 Physiological Systems; corequisite: 91706 Neuroscience*

This subject provides the introductory principles governing drug and xenobiotic action to be developed further in Pharmacology 2. It is designed to foster a problem-solving approach to pharmacology with particular emphasis on applying molecular pharmacology concepts to pathophysiological problems. Major objectives will be to develop the concepts of dose response relationships and the specificity of drug action. Therapeutic index and the concept of selective toxicity. Pharmacokinetic factors and their role in pharmacotherapy. Chemical neurotransmitters, ion channels and receptors as determinants of drug action in the central and peripheral nervous systems. Clinical efficacy of the major pharmacology drug classes used in the treatment of pathophysiological processes involving the cardiovascular, renal and nervous systems. Lectures are complemented by a tutorial/practical program which emphasises the

clinical nature of the subject and develops lecture material using a variety of experimental, tutorial, computer-simulation and case-study approaches.

### 91708

#### Psychophysiology

8cp; 6hpw; prerequisite: 91704 Behavioural Sciences

This subject builds on material provided in Behavioural Sciences. It provides the student with a solid grasp of the relationship between mind and behaviour with emphasis upon the underlying physiological mechanisms. Implications for health are emphasised throughout the course. The unit will encourage the student to evaluate the connections believed to occur between attitudes, behaviour, lifestyle, physiology, and health outcome. Lectures are complemented by practical workshops and discussion in tutorials.

### 91709

#### Pharmacology 2

8cp; 6hpw (average); prerequisite: 91707 Pharmacology 1

This subject develops and extends the principles governing drug and xenobiotic action covered in Pharmacology 1. Objectives are to further develop the concept of receptors as cellular determinants of drug and xenobiotic action and to develop the concepts of modulated receptors and ion channels in determining anaesthetic drug action. The clinical efficacy of the major pharmacology drug classes used in the treatment of diabetes and respiratory and musculoskeletal systems disorders. Endogenous opioids in pain control mechanisms and the interaction of opioid analgesics with these systems. Selective toxicity in the treatment of microbial, viral and protozoal infections. Toxicokinetic factors, defence mechanisms, cellular reactivity, receptors and binding sites as determinants of target organ toxicity. Drugs in the conception and birthing process. Carcinogens and teratogens. Specific classes of toxic substances. Lectures are complemented by a tutorial/practical program which emphasises the clinical nature of the subject and develops lecture material using a variety of experimental, tutorial, computer simulation and case-study approaches.

### 91777

#### Master's Thesis (Biol and Biomed) F/T

This research project can be undertaken only following negotiation by the student with a full-time member of academic staff in order to gain agreement to be individually supervised. It also requires special permission of the appropriate Head of Department and Associate Dean.

### 91778

#### Master's Thesis (Biol and Biomed) P/T

This research project can be undertaken only following negotiation by the student with a full-time member of academic staff in order to gain agreement to be individually supervised. It also requires special permission of the appropriate Head of Department and Associate Dean.

### 91987

#### PhD Thesis (Biol and Biomed) P/T

This research project can be undertaken only following negotiation by the student with a full-time member of academic staff in order to gain agreement to be individually supervised. It also requires special permission of the appropriate Head of Department and Associate Dean.

### 91988

#### PhD Thesis (Biol and Biomed) F/T

This research project can be undertaken only following negotiation by the student with a full-time member of academic staff in order to gain agreement to be individually supervised. It also requires special permission of the appropriate Head of Department and Associate Dean.

### 91997

#### Professional Experience (Biol/Biom) F/T

Part-time students employed full-time in an area relevant to their course, should enrol in this subject in every semester for which they are employed.

**Note:** While such enrolment will be listed on the academic record to indicate employment while studying, Professional Experience subjects do not incur a HECS liability.

**91999****Professional Experience (Biol/Biom)  
P/T**

All full-time students employed part-time in an area relevant to their course should enrol in this subject in **every** semester for which they are employed.

**Note:** While such enrolment will be listed on your academic record to indicate your employment while studying, Professional Experience subjects do not incur a HECS liability.

**95556****Technology, Society and Change**

*6cp; prerequisites: 48 credit points*

The subject will consist of three to four modules which engage students in an interdisciplinary approach to understanding the relationships and interdependence between society, technology and change. Students will identify the need, power and limitations of theory which explain and shape interfaces between technology and society. Critical analyses of case studies which illustrate these objectives will provide a base on which to construct a conceptual framework which enables students to evaluate social and technological developments and change.

**98702****Coastal Ecosystems**

*4cp*

Normally held over two field excursions at Jervis Bay (February) and Heron island (July). This subject introduces the basic ecological principles students shall need for the understanding and appreciation of coastal issues. As such it applies those principles to the practical study of issues in marine, estuarine and tropical reef environments with real hands-on experience. Material covered includes a range of aspects concerning the marine environment including chemical, biological, geological and physical oceanography, in addition to the biology of corals and fishes, benthic fauna, plants and sediments. Lectures are complemented by an extensive field program, and assessment is gained by final written exam and project reports.

**98703****Public Administration and Management**

*4cp; 3hpw*

Deals with the human aspects of management for organisations that have some responsibility over coastal resources. It examines both internal matters, such as organisational structure and function, as well as external issues, such as conflict resolution and negotiation with other groups in the community. It recognises that coastal resource management goals can be achieved only by organisations which are themselves effectively managed, and which deal appropriately with external groups that have an impact on the achievement of these goals.

**98704****Biotic Resources**

*4cp; 3hpw*

Freshwater, estuarine and marine biological resources and their exploitation will be examined. Problems of productivity against a background of regulations will be studied, and the major management requirements for ecologically sustainable development of coastal resources will be addressed. NSW and Australian practices shall be examined in relation to best practices elsewhere.

**98705****GIS and Resources Assessment**

*4cp*

The principles of baseline surveys, biomonitoring, and impact assessment in systems such as mangroves, saltmarshes, seagrass beds, estuarine and lagoon waters and sediments, and marine systems will be developed. Applications using GIS and remote sensing shall be examined, and their uses expounded.

**98706****Coastal Planning**

*4cp*

The aims of planning will be analysed: functional, economic, social, environmental and aesthetic. The planning process in theory will be explored, and the reality of planning processes will be compared and contrasted with the theoretical models. Case studies from Australian coastal areas and overseas examples will be used.

**98707****Topics in Coastal Management***4cp*

A detailed seminar program over two semesters. Topics relevant to the current political agenda, local and state government needs, and the international scene, relevant to integrated coastal management, to be presented by visiting speakers. Normally weekly, some topics shall be held over to a workshop format over several days as needed. Alternatives include participation in relevant workshops and/or conferences.

**98708****Risk Assessment and Management***6cp*

This subject provides an introduction to methods of risk assessment. An understanding of the concepts of risk perception, risk communication, risk acceptability and the modification of risks and their application to environmental engineering, impact assessment and auditing, together with capabilities essential to environmental risk assessment, is developed. Topics include: semantics of risk and hazard; risk as a social construct; principles of risk management; steps in risk engineering; risk perception, risk communication, and acceptability of risks; statutory provisions in NSW relating to environmental risks; legal principles relating to environmental risks (liability etc); checklists and scoping for impact assessment and auditing; risks to health and to ecosystems; comparing risks, quantified and qualitative risk assessment methods; discussion of some specific environmental hazards in the context of risk amelioration, risk assessment in emergencies; financial tools in the management of environmental risks; environmental auditing procedures.

**98709****Urban Stormwater Management***6cp*

This subject develops understanding of the nature of pollution processes and levels in urban situations, and of engineering systems for the reduction of pollution, particularly in receiving waters. Students consider pollution management systems in terms of social and environmental requirements and the rationale for design and implementation of remedial measures.

**98711****Coastal Resource Policy***6cp*

This introductory subject provides pointers to most aspects of the course, starting with a consideration of the definition of the coastal zone and coastal resources. Discussion of regulatory frameworks, in Australia and overseas, and the roles of organisations involved in coastal resource management. The interdisciplinary nature of coastal resources problems, conflicts and issues will also be considered.

**98713****Coastal Processes***6cp*

An introduction to physical processes in rivers, estuaries and marine waters. Stream flows, mixing patterns, generation processes of water waves and tides, and sediment-transport processes will be dealt with. The interactions of these processes with coastal engineering activities will be emphasised.

**98716****Geological Resources***4cp; 3hpw*

The development of coastal systems through time will be considered. Topographic and bathymetric maps and their interpretation will be introduced. The nature and dynamics of sandy barrier coasts, coral reefs, cliff-dominated erosive coasts, and aggregates of mineral resources and their exploitation will be examined. Geological implications in coastal zone management and planning will be considered.

**98718****Pollution Assessment***4cp; 3hpw*

Concentrates on the sources, impacts and control of pollutants on coastal systems. The ecological characteristics of natural and disturbed habitats will be compared. The ecological and public health impacts of pollution will be considered. The objectives, approaches, design and evaluation of monitoring programs will be studied, including remote sensing and other techniques. Oil spill fingerprinting and clean-up strategies will be introduced, and the role of regulatory and management agencies considered.

**98719****Tourism, Recreation and Protected Area Management***4cp; 3hpw*

Examines the management issues arising from the use of coastal areas for leisure. The Australian coast, particularly its natural areas, is a significant site for recreation and tourist activities. To ensure that these areas are managed sustainably, it is essential to consider the impacts and implications of this use for the natural coastal systems and to develop techniques that will allow this use to continue.

**99502****Foundations of TCM***6cp; 5hpw*

The theoretical and philosophical components of the subject have a continuing and progressive application in all aspects of TCM. This subject provides a broad foundation for the traditional Chinese medical view of health, disease aetiology and diagnostic systems and principles of treatment which will be built upon throughout the training program. Pulse diagnosis, one of the cornerstones of the traditional Chinese diagnostic system, is included in this subject.

**99509****Special Points and Systems***5cp; 5hpw; prerequisites: all subjects of Stage 2*

This subject examines the functions of categories of acupuncture points and the use of these points in various theoretical perspectives. In particular the six division, triple heater and four radical theories are studied in the context of disease progression through body levels. The eight extra and antique point systems provide additional perspectives from which to view health, illness and the flow of *qi*.

**99511****History and Philosophy of TCM***6cp; 6hpw; prerequisites: 99571 Chinese Diagnostic System; 99509 Special Points and Systems; corequisites: 99576 Advanced Chinese Diagnosis*

This subject studies the theoretical structure of traditional Chinese medicine and its influence upon the holistic approach to healing and preventative therapy. It focuses on the classical literature of Chinese medicine and

some of the more complex theories arising from it.

**99517****Project Workshops***3cp; 2hpw; prerequisite: 91607 Research Methods 1; corequisite: 91608 Research Methods 2*

These workshops are designed to assist the student to bridge the gap between reflection on desirable areas of investigation and the submission of concrete projects. The workshops provide an atmosphere that encourages discussion and the sharpening of the students' focus on specific aims and objectives in essay writing. Mentoring groups are established that will guide the student through the development of his or her essay to its completion.

**99521****Clinical Acupuncture***5cp; 5hpw; prerequisites: all subjects of Stage 5; corequisites: all acupuncture subjects of Stage 6*

In the final year of training the student will be responsible for patient care, treatment and clinical management under the supervision of a practitioner. This subject prepares the student for this increased degree of clinical responsibility, as well as integrating material and skills previously studied.

**99527****Hospital Training in China***One month of hospital internship at Guangzhou University of Traditional Chinese Medicine, People's Republic of China (optional); 6cp (may be approved as fulfilling 50 per cent of credit points requirement for 99538 Clinical Internship (A&M)); prerequisite: completion of coursework for the Bachelor of Health Science in Acupuncture*

Experiencing first-hand the full acceptance of acupuncture within the cultural and medical framework of China increases the self-confidence of the student. After an initial introduction and briefing period, students enter the affiliated hospital system of the UTS College of Traditional Chinese Medicine under the direction of the doctor in charge of the acupuncture outpatients' department.



**99528****An Introduction to Tai Qi Chuan***3cp; 3hpw*

*Tai Qi Chuan* is one of the physical therapies of traditional Chinese medicine. This elective subject introduces basic forms of these rhythmic exercises which aim to increase health and wellbeing. Together *qi gong* and *tai qi* subjects provide a traditional method for maintaining health.

**99529****A Systems View of Life***3cp; 3hpw*

Concepts of traditional Chinese medicine that stem from a holistic world view differ from the fragmented and mechanistic view that has dominated European thought for the past 300 years. This elective subject offers an encompassing conceptual model for all sciences and a bridge between differing world views.

**99530****Philosophy, Religion and Culture***3cp; 3hpw; prerequisite: 99502 Foundations of TCM*

This elective subject widens the future practitioners' concepts of health and health care attitudes among their own cultural group and that of other cultural groups. Two societies are examined: multicultural Australia and modern China.

**99531****The Subtle Dimensions of Healing***3cp; 3hpw*

In the ancient texts acupuncture therapy was linked with a range of other factors bearing on health care, such as music and aroma. This elective introduces some of these areas which can subsequently be explored as personal interest determines. It contributes to professional competency by extending the student's ability to identify and work with interrelated dimensions of the healing process.

**99532****Social Crisis***3cp; 3hpw; prerequisite: 92167 Foundations of Helping and Caring*

This elective subject is designed to make the acupuncture student aware of the implications of various types of crisis situations they may encounter in practice, and the impact such

events may have on patients and their families. This subject identifies community resources and informs the student of what happens after referral.

**99533****Acupuncture Health Politics in Australia***3cp; 3hpw*

As part of the elective program this subject widens understanding of attitudes and health care politics among various professional groups, including acupuncturists. Acupuncture has formed a part of the wide consumer and health care challenge to orthodox medicine, both in Australia and overseas, and future practitioners should understand the issues and the role of the acupuncture profession in this process.

**99535****Nutrition in a Traditional Chinese Medical Context***3cp; 3hpw*

This elective subject is designed to assist in the clinical practice of acupuncture in the Australian social setting by equipping the future practitioner with the necessary skills to advise patients on the appropriate use of vitamins, minerals, foods and diets. It builds on the concepts of food therapy that are a basic aspect of the concordances of traditional Chinese medicine.

**99536****First Aid Certificate Course***St John's Ambulance course or approved training organisation; note: this subject does not carry academic credit*

It is required that all students hold a current senior certificate in first aid, or equivalent qualification, before undertaking an internship in a clinic of the UTS College of Traditional Chinese Medicine as a 'student-practitioner'.

**99537****Independent Research Project (Postgraduate)***7cp; prerequisites: 91607 Research Methods 1; 91608 Research Methods 2*

This is an area of self-directed study based on previous training, clinical experience and wide reading in acupuncture and allied subjects. The project provides the student with the

opportunity to extend his or her knowledge through undertaking acupuncture research.

### 99538

#### **Clinical Internship (A&M)**

*12cp; 250 hours of supervised clinical practice and completion of 20 case histories; prerequisites: satisfactory completion of all Stage 1–6 subjects*

The student experiences the full range of practitioner responsibilities under the supervision of a clinical manager. This area of training is accomplished in the outpatient clinic of the UTS College of Traditional Chinese Medicine which provides low-cost acupuncture services to the public.

### 99539

#### **Pathophysiology 1 (TCM)**

*6cp; 6hpw; prerequisite: 99570 Health Sciences 2*

The immune system and its role in resistance to disease. The main groups of micro-organisms which affect humans – their biology, concept of normal flora, opportunistic pathogens and compromised host. Epidemiology. Methods of limiting spread of micro-organisms and controlling infection. Alterations in endocrine function. Alterations in musculoskeletal function. Alterations in nutrition and metabolism. Alterations in motility, malabsorption. Alterations in function of the liver. Hepatitis. Alterations in gallbladder function. Diabetes; types, acute and chronic complications.

### 99540

#### **Pathophysiology 2 (TCM)**

*6cp; 6hpw; prerequisite: 99539 Pathophysiology 1 (TCM)*

Cellular homeostasis and normal and abnormal cellular growth and development. Diseases of blood. The major classes of cardiovascular disorders and their evolution from normal control mechanisms. The major respiratory disease processes and their relationship to normal respiratory function and defence mechanisms. The major urinogenital disorders of males and females including acute and chronic renal failure, prostatitis, dysmenorrhoea, disorders of menopause. The major types of fluid and electrolyte disturbances and their contribution to altered homeostasis. Selected nervous system disorders including epilepsy and Parkinson's disease. Basic principles of pharmacology with specific emphasis on drugs used in the

treatment of cardiovascular, respiratory, renal and nervous system disorders. Principles of absorption, metabolism, distribution and excretion of drugs and how they relate to onset and duration of action. Mechanisms of action and side effects of therapeutic groups of drugs that affect organ systems. Principles of anaesthesia and analgesia. Interactions of drugs both beneficial and adverse. Problems of toxicity, tolerance and addiction.

### 99543

#### **Qi Gong: Its Use in Acupuncture**

*3cp; 3hpw*

*Qi gong* is an ancient aspect of health care in traditional Chinese medicine that is re-emerging in China as a major part of the practitioner's own health care regime. This elective subject introduces *qi gong* breathing and concentration which calms the mind and aids in the restoration of health. The use of *qi gong* by the practitioner is also reputed to increase the effectiveness of *tuina* (Chinese massage).

### 99548

#### **Introduction to Traditional Acupuncture Theory**

*5cp; 3hpw*

This subject is designed to introduce biomedically trained health practitioners to some of the major theoretical foundations of acupuncture. It explains the traditional concept of *qi* (energy) and its interrelationship with the body in health and disease. The focus of the course is the acupuncture treatment of musculoskeletal disorders and sports injuries and therefore the emphasis of this subject is on the traditional Chinese medicine theories that underpin the acupuncture treatment of these disorders.

### 99549

#### **Point Location**

*4cp; 3hpw*

Accurate point location is an essential skill for competent acupuncture practice. Emphasis is given to those points that are of major importance in the delivery of musculoskeletal acupuncture therapy. Points will be examined in relation to their location, depth, action, special precautions and contra-indications. All classes are provided in a workshop environment.

**99550****Research Workshops I***3cp; 2hpw*

A critical examination of current research is an important aspect of all graduate studies. This course provides opportunities for students to evaluate several areas of recent investigation. This work is undertaken in an interactive workshop environment and opportunities are provided for students to develop and design their own research models which can be analysed and discussed in the light of a growing awareness of the neuro-humeral effects of acupuncture therapy.

**99551****The Chinese Medical Approach to Health and Disease***5cp; 3hpw; prerequisite: 99548 Introduction to Traditional Acupuncture Theory*

This subject provides the student with an understanding of the major causes and types of disease from the traditional Chinese viewpoint. It familiarises the future specialist acupuncture practitioner with the overall objectives of treatment. The student also gains a knowledge of Chinese medical terminology that will assist them in wider reading.

**99552****The Chinese Model of Qi and its Pathways***4cp; 3hpw; prerequisite: 99548 Introduction to Traditional Acupuncture Theory*

The physiology of energy and its pathways extend the students' knowledge of the *jing luo* (channel) system in relation to the practice of musculoskeletal acupuncture and the enhancement of sporting performance. It not only provides an understanding of how to influence energy but, through an awareness of energy production, enables the practitioner to utilise methods of assisting athletic performance and recovery from injury.

**99553****Clinical Practice I***3cp; 3hpw; prerequisites: 99548 Introduction to Traditional Acupuncture Theory; 99549 Point Location; corequisites: 99551 The Chinese Medical Approach to Health and Disease; 99552 The Chinese Model of Qi and its Pathways*

Clinical experience gives an immediacy and a sense of purpose to specialised acupuncture education. It is provided to graduate students

within the University's acupuncture clinics. These clinics are open to the public and are staffed by qualified practitioners assisted by students. Before entering the clinical environment students are provided with pre-clinical training to ensure that they are familiar with clinical requirements and regulations. Students will then take up the role of clinical assistant that enables them to gain valuable experience.

**99554****Acupuncture Diagnosis of Musculoskeletal Disorders***5cp; 3hpw; prerequisites: 99551 The Chinese Medical Approach to Health and Disease; 99552 The Chinese Model of Qi and its Pathways*

Correct diagnosis is an essential aspect of selecting appropriate treatment. These workshop sessions provide a hands-on approach to the diagnosis of musculoskeletal disorders according to the principles of traditional Chinese medicine. By this stage students will understand the theoretical basis for the correct diagnosis of a number of musculoskeletal problems. Practice is provided in the traditional Chinese medical assessment of joint and soft tissue disorders, paralysis, sports injuries, rheumatic and arthritic conditions.

**99555****Therapeutic Techniques and Tuina (Chinese Massage)***4cp; 3hpw*

This component develops treatment skills by combining and applying the techniques of acupuncture, acupressure and *tuina*. This will enable the student to provide effective and safe therapeutic skills appropriate to their level of training as practitioners in their own clinics or under supervision in the University's outpatient clinics.

**99556****Research Workshops 2***3cp; 2hpw; prerequisite: 99550 Research Workshops I*

This subject builds on the work undertaken in 99550 Research Workshop 1. The participating student, having acquired an understanding of the special needs of research in acupuncture, and some of the mechanisms implicated in the acupuncture effect, is at this stage required to design a small research proposal into an aspect of acupuncture. It is expected that the proposal

will deal with an area of musculoskeletal therapy or sports medicine that could be a feasible area of research.

### 99557

#### **Acupuncture Treatment of Musculoskeletal Disorders**

*5cp; 3hpw; prerequisites: 99554 Acupuncture Diagnosis of Musculoskeletal Disorders; 99555 Therapeutic Techniques and Tuina*

This subject builds on the theoretical foundation of traditional acupuncture and the work undertaken in 99554 Acupuncture Diagnosis of Musculoskeletal Disorders. In that subject the student developed skills in evaluating the condition of the patient by integrating diagnostic information and proposing appropriate approaches to treatment. In this subject the student takes the process to the next stage and applies treatment under the supervision of the lecturer. This complements the role of the graduate student in 99559 Clinical Practice 2.

### 99558

#### **Acupuncture Microsystems**

*4cp; 3hpw; prerequisite: 99549 Point Location*

The special areas of acupuncture demonstrated and practised in this subject have wide application in the general practice of acupuncture as well as musculoskeletal areas. Microsystems are generally used to reinforce and enhance the action of body acupuncture but they may also be used as a system on their own, particularly in emergency situations such as the treatment of minor sports injuries. Much of the information contained in this subject is applicable in the areas of sports medicine and pain control.

### 99559

#### **Clinical Practice 2**

*3cp; 3hpw; prerequisite: 99553 Clinical Practice 1; corequisite: 99557 Acupuncture Treatment of Musculoskeletal Disorders*

This subject provides practical experience in the responsible delivery of acupuncture services within a working clinical environment. The student has experienced this environment as an assistant to a practitioner during the first part of the program. The graduate student now assumes an internship role within the University's acupuncture clinic as an acupuncturist, specialising in musculoskeletal acupuncture and acupuncture sports medicine.

### 99560

#### **Introduction to TCM**

*6cp; 5hpw; corequisite: 99557 Acupuncture Treatment of Musculoskeletal Disorders*

An introduction to the basic theoretical concepts of traditional TCM that provides an overview of the program and helps to bridge the gap between the biomedical and traditional Chinese approach to health. The subject offers foundation knowledge and skills for the practice of TCM. It provides the traditional physiology of the 12 organs and 14 major channels.

### 99561

#### **Clinical Theory and Clinic – Level I (A&M)**

*3cp; workshop and clinical observation sessions: 2hpw; Clinical Assistant Level 1: 15 hours; corequisites: 99560 Introduction to TCM; 99502 Foundations of TCM; 99563 Health Sciences I (TCM)*

Approximately 20 per cent of the undergraduate training program is devoted to gaining clinical experience in preparation for becoming a qualified TCM practitioner. This subject prepares students for the role of clinical assistant and introduces them to the clinical environment.

### 99562

#### **Clinical Theory and Clinic – Level I (CHM)**

*3cp; workshop and clinical observation sessions: 2hpw; Clinical Assistant Level 1: 15 hours; corequisites: 99560 Introduction to TCM; 99502 Foundations of TCM; 99563 Health Sciences I (TCM)*

Approximately 20 per cent of the undergraduate training program is devoted to gaining clinical experience in preparation for becoming a qualified TCM practitioner. This subject prepares the student for the role of clinical assistant and introduces them to the clinical environment.

### 99563

#### **Health Sciences I**

*6cp; 6hpw*

This subject provides an introduction to the anatomy and physiology of the healthy human body. Lectures are complemented by an appropriate practical program. The subject includes the following: the levels of

organisation in the body; basic anatomy, anatomical terms, surface anatomy and body regions and overview of major organ systems. Transport of materials across membranes, osmosis diffusion, active transport. The basic concepts of tissues and major organ systems. The general structure and functional significance of the major organ systems. Basic microbiology and aseptic techniques. Chromosomes, mitosis and meiosis, DNA, RNA. The structure, function and histology of the integumentary system, the musculoskeletal system, the gastrointestinal system, cardiovascular, lymphatic and renal systems. Nutrition, enzyme action indigestion.

### 99564

#### The Physiology of Qi

4cp; 3hpw; prerequisites: 99560 Introduction to TCM; 99502 Foundations of TCM

This subject extends the students' knowledge of the *jing luo* (channel) system in relation to the clinical practice of acupuncture. It also provides an understanding, not only of how to balance energy, but of the mechanisms of energy production and methods of assisting this system of production – an important aspect of preventative therapy.

### 99565

#### Point Location I (and Treatment Techniques)

6cp; practicals and tutorials: 4hpw; workshops: 14 hours; prerequisites: all subjects of Stage 1; corequisite: 99564 The Physiology of Qi

This subject deals with the location, depth, action, special precautions and contra-indications, from both an anatomical and traditional acupuncture viewpoint, of the major acupuncture points that will be used in clinical practice. This module complements the knowledge of point function provided in Introduction to TCM and The Physiology of Qi. Practical experience is provided by the introduction of acupressure and basic treatment techniques.

### 99566

#### Introduction to Botany

4cp; 3hpw

In this subject the student is familiarised with the aspects of botany that are relevant to the practice of Chinese herbal medicine. This includes the identification of plants, and parts of plants, and familiarity with their growing requirements.

### 99567

#### Introduction to Chinese Herbal Medicine

6cp; 6hpw; prerequisite: all subjects of Stage 1; corequisite: 99566 Introduction to Botany

This subject provides introductory information about the basic properties and functions of Chinese herbs and forms an essential foundation for an understanding of Chinese herbal formulae.

### 99568

#### Clinic – Level 2 (A&M)

4cp; Clinical Assistant Level 2: 15 hours;

prerequisites: all subjects of Stage 1; corequisites: 99570 Health Sciences 2; 99564 The Physiology of Qi

Clinical training is provided through the clinical program of the UTS College of Traditional Chinese Medicine at the specialist TCM centre provided by the University. It is open to the general public.

### 99569

#### Clinic – Level 2 (CHM)

4cp; Clinical Assistant Level 2: 15 hours;

prerequisites: all subjects of Stage 1; corequisites: 99570 Health Sciences 2; 99567 Introduction to Chinese Herbal Medicine; 99566 Introduction to Botany

Clinical training is provided through the clinical program of the UTS College of Traditional Chinese Medicine at the specialist TCM centre provided by the University. It is open to the general public.

### 99570

#### Health Sciences 2

6cp; 6hpw; prerequisites: 99563 Health Sciences 1

This subject completes the survey of healthy human anatomy and physiology begun in Health Sciences 1. Specifically it examines the endocrine, nervous, reproductive and respiratory systems including concepts of control systems and system interactions within the body. It also completes an introduction to basic microbiological concepts of disease transmission, sterilisation and asepsis. This unit also examines chemical and physical concepts that underpin the bioscience component. These include chemical measurement, solutions, chemical reactions involving carbohydrates, lipids and proteins, pH and acid-base analysis along with the physical principles of gas pressure,

temperature and flow, electricity and transmission of light and sound.

### 99571

#### Chinese Diagnostic System

*5cp; 5hpw; prerequisites: 99560 Introduction to TCM; 99502 Foundations of TCM; corequisite: 99509 Special Points and Systems*

This subject provides a deeper understanding of the objectives, application and therapeutic conclusions inherent in the traditional Chinese diagnostic system. It provides practical workshops in advanced pulse diagnosis that complement the theoretical work being offered in Special Points and Systems.

### 99572

#### Chinese Herbal Formulae

*5cp; 5hpw; prerequisites: all TCM subjects of Stage 2; corequisite: 99571 Chinese Diagnostic System*

Chinese herbal medicine utilises herbal combinations to treat illness. In this subject the major herbal formulae are evaluated together with their appropriate application. Students are encouraged to discriminate between various treatment strategies.

### 99573

#### Clinic – Level 3 (A&M)

*4cp; Clinical Assistant Level 3: 20 hours; prerequisites: all subjects of Stage 2; corequisite: 99539 Pathophysiology 1 (TCM); 99571 Chinese Diagnostic System; 99509 Special Points and Systems*

Clinical training is continued through the UTS College of Traditional Chinese Medicine.

### 99574

#### Clinic – Level 3 (CHM)

*4cp; Clinical Assistant Level 3: 20 hours; prerequisites: all subjects of Stage 2; corequisites: 99539 Pathophysiology 1 (TCM); 99571 Chinese Diagnostic System; 99572 Chinese Herbal Formulae*

Clinical training is continued through the UTS College of Traditional Chinese Medicine.

### 99576

#### Advanced Chinese Diagnosis

*6cp; 6hpw; prerequisite: 99571 Chinese Diagnosis; corequisite: 99511 History and Philosophy of TCM*

This subject contributes a large component of the essential skills and knowledge that are required for traditional Chinese diagnosis. The

subject and workshops underpin not only the clinical experiences of the student, but also the differentiation of disease states when biomedical and Chinese medical systems are integrated.

### 99541

#### Clinic – Level 4 (A&M) and Point Location 2

*6cp; Clinical Assistant Level 4: 35 hours; workshops: 2hpw; prerequisites: all subjects of Stage 3; corequisites: 99540 Pathophysiology 2 (TCM); 99511 History and Philosophy of TCM; 99576 Advanced Chinese Diagnosis*

This subject revisits and extends the students' knowledge of acupuncture point location as well as complementing the knowledge of point function provided in Advanced Chinese Diagnosis. Clinical training is continued through the clinical program of the UTS College of Traditional Chinese Medicine.

### 99577

#### Clinic – Level 4 (CHM) and Chinese Herbal Practice

*6cp; Clinical Assistant Level 4: 35 hours; workshops: 2hpw; prerequisites: all subjects of Stage 3; corequisites: 99540 Pathophysiology 2 (TCM); 99511 History and Philosophy of TCM; 99576 Advanced Chinese Diagnosis*

This subject revisits and extends the students' knowledge of script writing of Chinese herbal formulae. Clinical training is continued through the clinical program of the UTS College of Traditional Chinese Medicine.

### 99578

#### Microsystems

*6cp; 5hpw; prerequisite: 99576 Advanced Chinese Diagnosis; corequisite: 99582 Clinic – Level 5 (A&M) and Advanced Treatment Techniques*

The theoretical information provided by this subject is applied and practised in the subject workshops on Advanced Treatment Techniques. Much of the information contained in this subject is applicable to the treatment of sports injuries, pain control and paralysis.

**99579****Chinese Massage (Tuina)**

*6cp; workshops and clinical internship 4 x 14 hours (over 2 semesters); prerequisites: all subjects of Stage 4*

The subject combines the acupuncture techniques with general Chinese massage (*tuina*) techniques. It enables the student to assist the practitioner in the clinical situation where specific massage is required after the removal of needles to increase the effectiveness of acupuncture treatment.

**99580****Pharmacognosy**

*6cp; 5hpw; prerequisites: 99572 Chinese Herbal Formulae; 99540 Pathophysiology 2 (TCM)*

The student now has an understanding of basic chemistry and Western pharmacology. This subject relates that material to the specific area of Chinese herbs, examining the action of the active constituents of herbs, the toxicity of certain formulae and their synergistic effects in medicinal use.

**99581****Chinese Herbal Medicine I**

*6cp; 6hpw; prerequisites: all acupuncture subjects of Stage 4*

Chinese herbal medicine involves the diagnosis of specific disorders, and the discrimination of variations within these diagnosed disorders. Students are trained in the selection and formulation of individual herbal prescriptions appropriate to the patient's individual presenting symptoms. This subject provides the student with practice in analysing the presentation of various disorders, especially pulmonary and gastrointestinal conditions.

**99582****Clinic – Level 5 (A&M) and Advanced Treatment Techniques**

*6cp; Clinical Assistant Level 5: 35 hours; workshop: 2hpw; prerequisites: all subjects of Stage 4; corequisites: 99579 Chinese Massage (Tuina); 99578 Microsystems; 99584 Clinical Features of Disease*

This subject provides practical experience in the application of information provided in Microsystems and serves to integrate theory and develop advanced clinical skills. Clinical training is continued through the clinical

program of the UTS College of Traditional Chinese Medicine.

**99583****Clinic – Level 5 (CHM) and Chinese Herbal Practice**

*6cp; Clinical Assistant Level 5: 35 hours; workshop: 2hpw; prerequisites: all subjects of Stage 4; corequisites: 99580 Pharmacognosy; 99584 Clinical Features of Disease*

This subject extends the students' ability to dispense Chinese herbs within the clinical setting. Clinical training is continued through the clinical program of the UTS College of Traditional Chinese Medicine.

**99584****Clinical Features of Disease**

*6cp; 4hpw; prerequisite: 99540 Pathophysiology 2 (TCM)*

This subject builds on the theoretical material offered in Health Science 1 & 2. It also develops the students' ability to differentiate, in an acupuncture clinical setting, those conditions that should be referred to a medical practitioner or other health care professional.

**99585****Disease States**

*6cp; 6hpw; prerequisites: all acupuncture subjects of Stage 5*

The subject moves its emphasis from the 'learning' of acupuncture to the clinical practice of acupuncture. After determining that acupuncture is appropriate to the patient's condition, the student must then differentiate the pattern of disharmony as identified in Traditional Chinese Medicine, decide on the treatment principle and devise a course of treatment. Some of the conditions examined may include: paralysis (*wei* syndrome); neurological disorders; lumbar and back pain; disorders of neck and shoulders; musculoskeletal disorders, arthritis and rheumatism (*bi* syndrome), and sports enhancement.

**99586****Chinese Herbal Medicine 2**

*6cp; 6hpw; prerequisites: all acupuncture subjects of Stage 5*

Chinese herbal medicine involves the diagnosis of specific disorders, and the discrimination of variations within these diagnosed disorders. This subject builds on the

work undertaken in Chinese Herbal Medicine 1.

### 99587

#### Clinical Chinese Herbalism

*5cp; 5hpw; prerequisites: all subjects of Stage 5*

In the final year of training the student will be responsible for patient care, treatment and clinical management under the supervision of a practitioner. This subject prepares the student for this increased degree of clinical responsibility, as well as integrating material and skills previously studied. It emphasises diagnosis and treatment in the four main TCM specialist areas of gynaecology, dermatology, traumatology and paediatrics.

### 99588

#### Clinical Theory and Clinic – Level 6 (A&M)

*6cp; workshops and planning sessions: 2hpw; Clinical Assistant Level 6: 35 hours; prerequisites: all subjects of Stage 5*

This module builds on the first three years of theoretical, practical and clinical training and acquaints the student with skills and duties required by a 'student-practitioner' working in the University's outpatient clinic. Clinical training is continued through the clinical program of the UTS College of Traditional Chinese Medicine.

### 99589

#### Clinical Theory and Clinic – Level 6 (CHM)

*6cp; workshops and planning sessions: 2hpw; Clinical Assistant Level 6: 35 hours; prerequisites: all subjects of Stage 5; corequisites: 99586 Chinese Herbal Medicine 2; 99587 Clinical Chinese Herbalism*

This module builds on the first three years of theoretical, practical and clinical training and acquaints the student with skills and duties required by a 'student-practitioner' working in the University's outpatient clinic. Clinical training is continued through the clinical program of the UTS College of Traditional Chinese Medicine.

### 99590

#### Special Topics in TCM (Intermodal and Professional)

*8cp; 6hpw; prerequisites: 99585 Disease States*

This subject acquaints the student with the current requirements of private TCM practice.

Workshops are provided in: current research, bioethics and professional issues. This subject also encourages students to see themselves as part of the wider health care community. Intermodality exchange is encouraged by lectures from visiting specialists in areas such as osteopathy, physiotherapy and veterinary acupuncture.

### 99591

#### Practice Management

*4cp; 3hpw*

This subject emphasises the need for proper planning in the management of a small business. Issues such as professionalism, location, record-keeping, taxation, insurance, advertising, multidiscipline practices and legal requirements are examined.

### 99592

#### Clinical Internship (CHM)

*12cp; 250 hours of supervised clinical practice and completion of 20 case histories; prerequisites: satisfactory completion of all Stage 1–6 course subjects*

The student experiences the full range of practitioner responsibilities under the supervision of a clinical manager. This area of training is accomplished in the outpatient clinics of the UTS College of Traditional Chinese Medicine which provide low-cost TCM services to the public.

### 99593

#### Honours Project

*48cp (over 2 semesters); prerequisites: 91608 Research Methods 2; 99517 Project Workshops*

This is an area of self-determined study. The Honours research project provides the student with the opportunity to extend their knowledge under the guidance of a suitably qualified member of academic staff and to establish a foundation for the development of their professional research and research reporting skills.

### 99594

#### Chinese Herbal Practice I

*6cp; flexible learning program; prerequisites: all TCM units of Stage 2*

Chinese herbal medicine involves the diagnosis of specific disorders and the discrimination of variations within these diagnosed disorders. Students are trained in the selection and formulation of individual



herbal prescriptions appropriate to the patient's individual presenting symptoms. This subject provides the student with practise in analysing the presentation of various disorders, especially pulmonary and gastrointestinal conditions.

**99595****Graduate Clinic Level 3 (TCM)**

*2cp; Graduate Clinical Assistant Level 3: 10 hours; prerequisites: all units of Stage 2; corequisites: all units of Stage 3*

Clinical training is continued under the guidance of an experienced practitioner at the clinics of the College of Traditional Chinese Medicine. This subject is especially directed towards providing the student with confidence to undertake a full internship in the following semester.

**99596****Chinese Herbal Practice 2**

*6cp; flexible learning program; prerequisites: all TCM units of Stage 3*

Chinese herbal medicine involves the diagnosis of specific disorders, and the discrimination of variations within these diagnosed disorders. This subject builds on work undertaken in 99594 Chinese Herbal Practice 1.

**99597****Graduate Clinic Internship (CHM)**

*5cp; Graduate internship 25 hours as a supervised practitioner; prerequisites: all units of Stage 3; corequisites: all units of Stage 4*

The graduate herbal clinician will undertake 25 hours of supervised practise in the UTS Chinese herbal clinics.

**99598****Master's Project – Traditional Chinese Medicine – P/T**

*24cp; 2 semesters*

The Master's project provides the student with the opportunity to extend their knowledge under the guidance of a suitably qualified member of academic staff and to establish a foundation for the development of their professional research and research reporting skills.

**99599****Principles of Chinese Herbal Medicine**

*8cp; flexible learning program*

This subject offers foundation knowledge and skills for the practice of Chinese herbal medicine. As a graduate subject it is predicated by an extensive knowledge of Traditional Chinese Medical theory. It provides an introduction to the basic concepts of Chinese herbalism and its application.

**99600****Graduate Clinic Level 1 (CHM)**

*4cp; Graduate Clinical Assistant Level 1: 10 hours, dispensing workshop 2 x 4; corequisite: 99599 Principles of Chinese Herbal Medicine*

Students complete a workshop program that enables them to undertake basic herbal dispensing in the UTS clinic. Clinical training is provided through the clinical program of the College of Traditional Chinese Medicine at the specialist TCM centre provided by the University which is open to the general public.

**99601****Principles of Botany**

*4cp; flexible learning program*

A basic knowledge of botany and botanical terminology is essential for the understanding of Chinese herbal medicine. This subject provides the students with a grounding in plant identification, the parts of plants, and familiarity with their growing requirements.

**99602****Principles of Pharmacognosy**

*3cp; 2hpw; prerequisites: subjects of Stage 1*

The student has an understanding of basic chemistry and Western pharmacology. This subject relates that material to the specific area of Chinese herbs, examining the action of the active constituents of herbs, the toxicity of certain formulae and their synergistic effects in medicinal use.

**99603****Classical Herbalism**

*3cp; flexible learning program; prerequisites: subjects of Stage 1*

This subject surveys historical writings and classical texts that form the basis of modern Chinese herbal medicine.

**99604****Graduate Clinic Level 2 (CHM)**

*2cp; Graduate Clinical Assistant Level 2: 10 hours; prerequisites: all units of Stage 1; corequisites: all units of Stage 2*

Clinical training is provided through the clinical program of the College of Traditional Chinese Medicine at the specialist TCM centre provided by the University which is open to the general public.

**99605****Herbal Prescriptions**

*5cp; flexible learning program; prerequisites: all subjects of Stage 2*

This subject analyses the Chinese herbal formulae utilised in TCM to treat illness. The major herbal formulae are evaluated together with their appropriate application. Students are encouraged to discriminate between various treatment strategies.

## SUBJECTS OFFERED FOR FACULTY OF NURSING STUDENTS

**91518****Physiological Foundations of Health 1**

*6cp; Bioscience component 4hpw; Physical Science component 2hpw*

This subject introduces students to anatomy and physiology, levels of organisation and homeostasis. The subject covers the following topics: integumentary system – skin structure and function, specific and non-specific defence mechanisms, wound healing; introductory microbiology – transmission of micro-organisms, aseptic technique; the musculoskeletal system – bone structure, organisation of the axial and appendicular skeleton, joints, muscular system, muscle tissues, principal skeletal muscles, muscles and movement; the gastrointestinal system – anatomy and histology of the gastrointestinal tract, digestion and its control, absorption of nutrients; the hepatic portal system – the structure of the liver and its role in metabolism, fluid balance in the tissues; the cardiovascular system – structure of blood vessels and their distribution, heart function, blood pressure; the renal system – gross anatomy and histology of the kidney, waste product elimination, ultrafiltration and urine production, water and electrolytic balance; measurement – scientific notation and basic mathematics; electricity – static electricity, electric currents, magnetism, applications of electricity in the hospital and electrical safety; heat and temperature – heat transfer and temperature regulation of the body, fluids; the building blocks of life – molecular and ionic compounds; ions in the body – electrolytes, acids, bases and salts; how atoms join together to form molecules – obeying the rules of valence, polar and non-polar bonds, forces of attraction between molecules; hydrocarbons and lipids and the structure of lipid bilayers; biologically important families of carbon compounds; and chemical reactions in digestion and excretion.

**91519****Physiological Foundations of Health 2**

*6cp; Bioscience component 4hpw; Physical Science component 2hpw*

This subject covers the following topics: the endocrine system – the major endocrine glands and their hormones, feedback control of

hormones, hormone disorder; reproductive systems and development – anatomy of male and female reproductive systems, mitosis and meiosis, formation of gametes and fertilisation, hormones and the female reproductive cycle, pregnancy, an overview of embryonic and foetal development including development of major organ systems; the nerve cell – the nerve impulse and its propagation, synaptic transmission; nervous system organisation – the peripheral and autonomic nervous system, the segmental nature of the spinal cord, spinal and autonomic reflexes; the cranial nerves – introduction to main functional areas of the brain; voluntary movement – the neural pathway, light and sound; quantities of chemical substances – moles solutions and their concentrations, osmosis; the chemical basis for respiration and acid/base balance – chemical equilibrium, with acids and bases, pH and buffers, acidosis and alkalosis, and gases; respiratory system – gross and fine anatomy, mechanism of breathing, gas exchange and gas transport, role of haemoglobin, and oxygen dissociation curves.

**91520****Pathophysiology I**

*6cp; 6hpw*

This subject covers the following topics: the immune system and its role in resistance to disease; the main groups of micro-organisms which affect humans – their biology, concept of normal flora, opportunistic pathogens and compromised host; methods of limiting the spread of micro-organisms and controlling infection, including sanitation, sterilisation, disinfection, asepsis; and the use of specific nursing precautions and isolation procedures; the collection and transport of microbiological specimens; pathogenesis of specific common and/or serious infectious diseases; diseases acquired through the gastrointestinal tract, the urinary tract, the respiratory tract and the genital tract; diseases acquired parenterally either by trauma, insect bite or hospital procedures; alterations in nutrition and metabolism; alterations in motility, malabsorption; alterations in the function of the liver, hepatitis; alterations in gallbladder function; diabetes – types, acute and chronic complications; and alterations in nervous system function.

**91521****Pathophysiology 2**

*6cp; 6hpw*

This subject covers the following topics: cellular homeostasis and normal and abnormal cellular growth and development, and diseases of the blood; the major classes of cardiovascular disorders and their evolution from normal control mechanisms; the major respiratory disease processes and their relationship to normal respiratory function and defence mechanisms; the major renal disorders including acute and chronic renal failure; the major types of fluid and electrolyte disturbances and their contribution to altered homeostasis; basic principles of pharmacology with specific emphasis on drugs used in the treatment of cardiovascular, respiratory, renal and nervous system disorders; principles of absorption, metabolism, distribution and excretion of drugs and how they relate to onset and duration of action; mechanisms of action and side effects of therapeutic groups of drugs that affect organ systems; principles of anaesthesia and analgesia; interactions of drugs both beneficial and adverse; and problems of toxicity, tolerance and addiction.

## SUBJECTS OFFERED BY OTHER FACULTIES

Various general studies elective subjects available from other faculties are listed below. Further details are available from other faculty handbooks, or from the Information Office in each faculty.

### 023001

#### Psychology of Secondary Students

*Offered by the Faculty of Education*  
3cp; 3hpw

The aim of this subject is to provide students with the following: an understanding of the principles and patterns of human growth and development in the secondary school years; a knowledge of types of learning and their interaction with teaching approaches and strategies; and a knowledge of effective ways of interacting with students.

### 023002

#### Meeting Special Needs in the Secondary School

*Offered by the Faculty of Education*  
3cp; 4hpw

The aim of this subject is to provide students with effective ways of interacting with students; with strategies for identifying students with learning or behavioural difficulties; knowledge of how secondary school teachers can meet the challenges presented by students with special needs, including those with learning or behavioural difficulties, and gifted and talented students; and an understanding of the educational issues relevant to the use of alternative curricula and learning contexts, including alternate pathways in post-compulsory education.

### 023502

#### Social Bases of Education

*Offered by the Faculty of Education*  
4cp; 2hpw

Enables students to appreciate the nature of social relationships in the school and how these affect teacher and student behaviour; understand the education system in New South Wales and the role of the Federal Government in education; understand how social characteristics influence the educational outcomes of certain social groups; understand the part that the socialisation process plays in shaping educational outcomes; identify and

evaluate government and school policies and programs designed to address existing inequalities of opportunity and outcome; and study the implications of these for change in schools, the direction of social change, and the interaction between schools and society in this context.

### 023191

#### Secondary Practicum 1

*Offered by the Faculty of Education*  
12cp; 4hpw plus practical experience

This subject introduces students to professional practice in the secondary school by drawing together the theory and practice necessary for an effective educational practitioner. It enables students to address skills, understandings, procedures and policy issues that are essential to effective professional practice by all teachers in present-day secondary schools and assists them to combine the knowledge and insights which are provided by all the other subjects which they undertake in the program.

### 023192

#### Secondary Practicum 2

*Offered by the Faculty of Education*  
12cp; 3hpw plus practical experience

This subject prepares students for implementing current developments in learning and teaching by addressing a range of policy issues and their implications for professional practice in the school. An emphasis is also placed on the development of professional commitment and its implications for lifelong learning. Further integration of theory and practice occurs as students engage in and reflect upon their school-based practice.

### 028001

#### Learning in Science 1

*Offered by the Faculty of Education*  
7cp; 8hpw

This subject aims to develop the craft of teaching science while blending professional skill with suitable academic insights. The students will develop a range of approaches and strategies to use in the classroom and laboratory which reflect research findings in science education. They will develop a philosophy of teaching science consistent with current syllabuses and policies and demonstrate understanding of the professional

insights and demands of the practising science teacher.

### 028002

#### Learning in Science 2

*Offered by the Faculty of Education  
7cp; 8hpw*

This subject aims to prepare proficient beginning teachers in science. It is intended as a foundation for continuing professional development. On completion of this subject students will competently apply their educational studies to the teaching of science; be able to design, organise and evaluate methods and materials for science teaching; and have a theoretical framework on which to base their future careers in science teaching.

### 31871

#### Computing for Science

*Offered by the Faculty of Mathematical and Computing Sciences  
3cp; 3hpw; prerequisites: 31870 Introduction to Microcomputers; 33170 Basic Science Mathematics*

Structured programming. Elements of C: variables, control structures and formatting. File handling in C. Subroutines and functions; array structures; applications to numerical analysis and problems from the physical sciences.

### 33101

#### Mathematics I (Life Sciences)

*Offered by the Faculty of Mathematical and Computing Sciences  
3cp; 3hpw*

Aspects of measurement; sequences and series; convergence and limits; graphical representation of functions; sigmoid curve; differentiation; integration; elementary differential equations; periodic functions. All topics are illustrated by problems relevant to biology.

### 33106

#### Statistical Design and Analysis

*Offered by the Faculty of Mathematical and Computing Sciences  
6cp; 2 semesters; 3hpw*

This subject runs over two semesters and provides the theory and techniques needed in the design and analysis of experiments in the natural sciences. It covers descriptive statistics, measures of location and dispersion,

commonly used discrete and continuous distributions and simple random sampling. Statistical tests, both parametric and distribution free, are presented for a variety of designs, including paired trials, completely randomised design, block designs and designs with interaction terms or covariates. The analysis of linear, multiple and polynomial regression models is also presented, together with appropriate diagnostic techniques to determine the validity of the models.

### 33130

#### Mathematical Modelling I

*Offered by the Faculty of Mathematical and Computing Sciences  
6cp*

This subject will develop all the standard ideas of single variable calculus, but will use specific physical models to provide a context for the mathematical concepts. The material will appear for different purposes and in a different order to standard presentations. There are ties to experiments done in basic physics subjects to further reinforce the relevance of the mathematical concepts.

### 33172

#### Science Mathematics 2

*Offered by the Faculty of Mathematical and Computing Sciences  
3cp; 3hpw; prerequisite: 33171 Science Mathematics I*

An introduction to areas of application of differential and integral calculus in the physical sciences. Applications of differentiation; maximising functions; Newton's method for finding roots. Applications of integration; areas, volumes, mass centres, arc lengths. Techniques for integrating; integration by parts; use of trigonometric identities; partial fractions. Functions of many variables; partial differentiation; chain rule. Variable separable differential equations; applications.

### 33173

#### Science Mathematics 3

*Offered by the Faculty of Mathematical and Computing Sciences  
3cp; 3hpw; prerequisite: 33171 Science Mathematics I; corequisite: 33172 Science Mathematics 2*

Mathematical techniques for the physical sciences. Matrices; inverse; eigenvalues and eigenvectors. Three-dimensional coordinate

geometry; vectors. Hyperbolic and inverse hyperbolic functions. Linear and exact first order differential equations. Infinite sequences and series.

### 33190

#### Mathematical Modelling for Science

*Offered by the Faculty of Mathematical and Computing Sciences*  
6cp; 6hpw; no formal prerequisite but a knowledge of 2 Unit HSC Mathematics is assumed

Functions and their relationship to scientific experiments. Differentiability. Differential equations arising from scientific problems. Solution by series. Radioactive decay and exponential functions. Oscillatory motion and trigonometric functions. Integration. The logarithm function. Inverse functions. Inverse trigonometric functions. Solution of differential equations by integration and inverse functions. The computer algebra system Mathematica will be used for symbolic, graphical and numerical computations.

### 33221

#### Engineering Mathematics 2A

*Offered by the Faculty of Mathematical and Computing Sciences*  
3cp; 3hpw; prerequisites: 33172 Science Mathematics 2; 33173 Science Mathematics 3

Functions of several variables. Limits and continuity. Partial derivatives. Chain rule. Gradient. Differentials. Maxima and minima. Lagrange multipliers. Least squares. Double integrals in Cartesian coordinates. Repeated integrals. Application to areas and volumes. Jacobians. Use of polar coordinates. Centre of mass and moment of inertia of plates. Triple integrals in Cartesian coordinates. Repeated integrals. Spherical and cylindrical coordinates. Quadric surface. Applications to volume, centre of mass. Moment of inertia, surface area. Differential equations. First order variables separate and linear equations. Higher order linear equations. Homogenous constant coefficient linear equations. Methods of undetermined coefficients.

### 33230

#### Mathematical Modelling 2

*Offered by the Faculty of Mathematical and Computing Sciences*  
6cp; prerequisite: 33130 Mathematical Modelling 1

This subject will develop concepts of linear algebra and multivariable calculus, but using motivational examples more than is usual. Such examples include production problems, overdamped motion, the concepts of work and rotational motion and various concepts such as centres of mass and moments of inertia. The concepts of probability will be introduced and motivated by focusing on the determination of the reliability of a system of components, such as – electric circuit for fire detection, a suspension bridge or an engine's lubrication system. Subject material will include variance, skewness and kurtosis, probability distributions, conditional probability and bivariate probability.

### 33290

#### Computing and Mathematics for Science

*Offered by the Faculty of Mathematical and Computing Sciences*  
6cp; 6hpw; prerequisite: 33190 Mathematical Modelling for Science

In the computing component of this subject students will study a range of computing modules designed to give them basic computing application skills and some more advanced modules appropriate to their particular discipline. The mathematics component will include studies of simultaneous linear equations and their occurrence in scientific problems; methods for solving these equations using matrices and determinants; eigenvalues and eigenvectors; vectors in two and three dimensions; products of vectors; spatial geometry and coordinate systems; functions of several variables; partial derivatives; optimisation; method of least squares. The computer algebra system Mathematica will be used for symbolic, graphical and numerical computations.

**33330****Physical Mathematics**

*Offered by the Faculty of Mathematical and Computing Sciences*

*3cp; 3hpw; prerequisite: 33221 Engineering Mathematics 2A*

Vector calculus: vector fields, line and surface integrals, conservative fields, Green's theorem, divergence and curl, Gauss's theorem and the equation of continuity, Stokes's theorem and circulation. ODEs: series solutions of linear equations with non-constant coefficients, Legendre's and Bessel's equations and functions. Boundary value problems: one-dimensional heat and wave equations, separation of variables Fourier sine and cosine series, vibrating circular membrane. Fourier analysis: introduction to Fourier integral, the triangle, sign step, delta and sinc functions.

**33390****Mathematics and Scientific Software**

*Offered by the Faculty of Mathematical and Computing Sciences*

*6cp; 4hpw; prerequisite: 33290 Computing and Mathematics for Science*

Methods of Integration. Double and triple integrals and their application to scientific problems. The use of spherical and cylindrical coordinates. Linear algebra and its relationship to boundary value problems. Inner products and orthogonality. Separation of variables. Fourier series. An introduction to C and Mathematica programming in the context of problems from this subject and its prerequisite.

**33490****Computational Mathematics and Physics**

*Offered by the Faculty of Mathematical and Computing Sciences*

*6cp; 5hpw; prerequisites: 68201 Physics 2; 33390 Mathematics and Scientific Software*

This subject highlights the role of computational methods in the solution of models for physical systems. The mathematics strand provides a context for which computational techniques can be developed. Boundary value problems and partial differential equations, vector calculus and analysis of complex variables are needed to describe a wide variety of 'real world' problems and basic physics phenomena. The computational tools that will be developed to complement these analytical techniques

include numerical integration methods, Fourier techniques and matrix manipulations. Students will develop not only sophisticated modelling skills, but also will have gained insights into the process of modelling and the ability to make value judgments on model predictions. This is a generic skill that is very transferable to other fields. You will have developed a set of computational utilities that you will be able to re-use in later subjects and project work. A small group project spanning both components of the subject will form a major part of the assessment.

**50140****Modernisation and Social Change**

*Offered by the Faculty of Humanities and Social Sciences*

*8cp; 4hpw*

The aim of this subject is to provide students with an understanding of the processes of modernisation and social change in a comparative context using case studies in countries of Western Europe, Latin America, East and South-East Asia. The lectures will highlight a number of key issues, for example whether the processes of social change are universal or specific; the consequences of modernisation in and for the economy, politics, society, culture and ideology of non-Western societies; and whether the established Eurocentric analytical models are still useful in understanding the modern world. It will be emphasised that differing interpretations of modernisation flow from various relations of power which lead to a multiplicity of views on its meanings and significance.

There are no prerequisites for this subject.

**51368****Written and Oral Reporting**

*Offered by the Faculty of Humanities and Social Sciences*

*2cp; 2hpw*

This is a seminar course which focuses on the written and oral presentation of scientific and technical information in workplace settings for professionals in science-based disciplines. Areas covered include the qualities of scientific and technical writing, the tools of technical communication, oral presentation of science-based information, and effective workplace skills in communication.

**51389****Professional Writing and Communication**

*Offered by the Faculty of Humanities and Social Sciences*  
3cp; 2hpw

This is a practical workshop course designed to help students in health sciences improve their skills in written and speech communication. The course covers the variety of forms of written and oral communication required in health care settings and emphasises specific skills in the writing of essays and reports. Students will also develop their understanding of communication principles and processes.

**79991****Complex Forensic Cases (Law)**

*Offered by the Faculty of Law*  
6cp; 6hpw; corequisite: 65743 *Complex Forensic Cases (Chemistry)*

Students will receive training in the preparation of reports and in the presentation of evidence in court. A substantial component of this subject is a Moot Court.

**92167****Foundations of Helping and Caring**

*Offered by the Faculty of Nursing*  
4cp; 4hpw

Part 1: Interpersonal and Counselling Skills; Part 2: Theoretical Foundations of Psychological Health; Part 3: Human Responses to Health and Illness.

This subject will provide an understanding of Western models of health care with a particular focus on the psycho-social components contributing to health and disease. It facilitates the development of essential interpersonal skills required for the practice of acupuncture and a helping role.

**INTERNATIONAL STUDIES SUBJECTS**

Students enrolled in the combined **Bachelor of Science/Bachelor of Arts in International Studies (N004)** will study a major – a country or region of specialisation – as part of their degree. In 1998, the following majors are offered through the Institute for International Studies: Argentina, Australia and the Asia-Pacific Region, Chile, China, Croatia, France, Germany, Greece, Indonesia, Italy, Japan, Latin America, Malaysia, Mexico, Poland, Russia, Slovenia, South China, South-East Asia, Spain, Taiwan, Thailand and Ukraine. These majors will be taken in conjunction with one of the following Contemporary Society subjects: Contemporary China, Contemporary Europe, Contemporary Japan, Contemporary Latin America, or Contemporary South-East Asia. As part of the combined degree students will also enrol in In-country Study 1 and In-country Study 2 for the duration of their study at an institution of higher education in the country or region of their major.

For more information about International Studies subjects, please refer to the 1998 *Institute for International Studies Handbook*.

Students enrolled in Bachelor of Health Science in Acupuncture/Bachelor of Arts in International Studies (NH01) will study the following International Studies subjects.

**971101, 972101, 973101, 974101****Modern Standard Chinese Language and Culture**

*Offered by the Institute for International Studies*  
8cp per subject

Modern Standard Chinese is the Language and Culture program for students who are either complete beginners or who first learnt Chinese at school in Australia. There are two points of entry for this program: the first for complete beginners and the second for students who have successfully completed HSC-level Chinese. Students take four units in the program, usually either units 1–4 (beginners) or 3–6 (post-HSC), determined by their point of entry. In general, students who already know and use Chinese outside the formal education system, regardless of whether they also learnt Chinese at school, are directed to the Chinese Language and Culture program. All students who have previously studied the language (other than at the Institute) are



required to contact the Course Coordinator for a level placement interview.

Modern Standard Chinese aims to develop the communicative competence students need in general social and professional interactions where the language (also known as Mandarin, *Putonghua* or *Guoyu*) is used in oral and written forms. A communicative approach is adopted for classroom instruction and students are expected to participate fully in class activities in the process of acquiring practical language skills. The teaching incorporates an introduction to Chinese culture and helps students to appreciate the wider cultural ramifications of Chinese in various contexts. The program will lay a solid foundation for further Chinese cultural studies.

Further descriptions of each subject can be found in the 'Language Studies' section of the *Institute for International Studies Handbook*.

### **976111**

#### **Contemporary China**

*Offered by the Institute for International Studies  
8cp; 4hpw*

This subject examines the contours and dynamics of social, political and economic changes in the People's Republic of China since the death of Mao Zedong and the start of the reform era. A central theme is the emerging relationship between state and society in a state socialist system in the process of change and reform. It is an introductory subject that requires no prior knowledge of the People's Republic of China or of any Chinese language.

### **977111**

#### **In-country Study 1: China**

*Offered by the Institute for International Studies  
24cp; prerequisite: completion of 4 semesters of  
study in the International Studies program*

### **978111**

#### **In-country Study 2: China**

*Offered by the Institute for International Studies  
24cp; prerequisite: 977111 (above)*

# ***Alphabetical list of subjects***

Acupuncture Diagnosis of Musculoskeletal Disorders	99554	Biochemistry 2	91320
Acupuncture Health Politics in Australia	99533	Biocomputing	91395
Acupuncture Microsystems	99558	Biological Evidence	91141
Acupuncture Treatment of Musculoskeletal Disorders	99557	Biological Hazards and Toxicology	69324
Advanced Chinese Diagnosis	99576	Biology 1	91311
Advanced Electron Microscopy Techniques	68557	Biology 2	91312
Advanced Engineering Geology	66607	Biology and Ecology	91150
Advanced Fossil Fuels	66605	Biomedical Science Upgrade	91609
Advanced Geological Mapping	66506	Biomedical Sciences 1	91412
Advanced Materials and Characterisation	67652	Biomedical Sciences 2	91413
Advanced Mathematics and Physics	68038	Biomonitoring	91315
Advanced Petrology	66502	Bioprocessing	91368
Advanced Petrology (Honours)	66552	Biosystems	91493
Advanced Solid-state Physics	68655	Biotic Resources	98704
Advanced Structural Geology	66505	Case Studies in Clinical Biochemistry	91419
Advanced Structural Geology (Honours)	66551	Chemical Process Control	65502
Advanced X-ray Techniques	68556	Chemical Safety	65504
An Introduction to <i>Tai Qi Chuan</i>	99528	Chemical Safety (OHS)	69332
Analytical Biochemistry	91326	Chemical Safety and Legislation	65410
Analytical Biochemistry Project 1	91414	Chemical Thermodynamics	65404
Analytical Biochemistry Project 2	91415	Chemistry 1A	65012
Analytical Chemistry 1 (new)	65306	Chemistry 1C	65101
Analytical Chemistry 1 (old)	65401	Chemistry 2	65021
Analytical Chemistry 2 (Advanced)	65551	Chemistry 2A	65022
Analytical Chemistry 2 (new)	65409	Chemistry 2C	65201
Analytical Chemistry 2 (old)	65501	Chemistry and Materials Science	60101
Analytical Chemistry 3 (new)	65606	Chemistry and Pharmacology of Illicit Drugs	65741
Analytical Techniques in Clinical Biochemistry	91426	Chinese Diagnostic System	99571
Anatomical Pathology	91354	Chinese Herbal Formulae	99572
Animal Ecophysiology	91363	Chinese Herbal Medicine 1	99581
Applied and Environmental Microbiology	91369	Chinese Herbal Medicine 2	99586
Applied Clastic Basin Analysis (Honours)	66653	Chinese Herbal Practice 1	99594
Applied Mechanics	68402	Chinese Herbal Practice 2	99596
Applied Mechanics S	68742	Chinese Massage ( <i>Tuina</i> )	99579
Applied Organic Chemistry 2	65702	Classical Herbalism	99603
Applied Organic Chemistry 2 (Advanced)	65752	Clinic – Level 2 (A&M)	99568
Applied Physics (Materials)	68071	Clinic – Level 2 (CHM)	99569
Applied Physics 1	68312	Clinic – Level 3 (A&M)	99573
Applied Physics 2	68412	Clinic – Level 3 (CHM)	99574
Applied Physics 3	68512	Clinic – Level 4 (A&M) and Point Location 2	99541
Applied Thermodynamics	68603	Clinic – Level 4 (CHM) and Chinese Herbal Practice	99577
Applied Thermodynamics S	68763	Clinic – Level 5 (A&M) and Advanced Treatment Techniques	99582
Approved External Subject	68943	Clinic – Level 5 (CHM) and Chinese Herbal Practice	99583
Approved External Subject	68946	Clinical Acupuncture	99521
Aquatic Ecology	91364	Clinical Bacteriology	91338
Australian Biota	91309	Clinical Biochemistry 1	91344
Australian Soils	91308	Clinical Biochemistry 2	91345
Basin Analysis	66405	Clinical Biochemistry – Advanced Aspects	91467
Behavioural Sciences	91704	Clinical Chinese Herbalism	99587
Biochemical Pathophysiology	91411	Clinical Features of Disease	99584
Biochemistry 1	91313		

## 174 ALPHABETICAL LIST OF SUBJECTS

Clinical Internship (A&M)	99538	Electromagnetics and Optics	68611
Clinical Internship (CHM)	99592	Electronics	68314
Clinical Laboratory Management	91417	Electronics 2	68404
Clinical Practice 1	99553	Electronics 2 S	68744
Clinical Practice 2	99559	Electronics and Interfacing	68514
Clinical Theory and Clinic – Level 1 (A&M)	99561	Engineering and Environmental Geology	66501
Clinical Theory and Clinic – Level 1 (CHM)	99562	Engineering Geology	66610
Clinical Theory and Clinic – Level 6 (A&M)	99588	Engineering Mathematics 2A	33221
Clinical Theory and Clinic – Level 6 (CHM)	99589	Environmental and Quaternary Geology	66609
Coastal Ecosystems	98702	Environmental Assessment and Planning	49121
Coastal Planning	98706	Environmental Chemistry	65601
Coastal Processes	98713	Environmental Chemistry (Advanced)	65651
Coastal Resource Policy	98711	Environmental Engineering and Management Practices	49122
Coastal Zone Law	91479	Environmental Management Procedures	91327
Community and Population Ecology	91307	Environmental Measurement	91376
Complex Forensic Cases (Chemistry)	65743	Environmental Microbiology	91328
Complex Forensic Cases (Law)	79991	Environmental Microbiology for Engineers	91651
Composites (new)	67608	Environmental Risk Assessment and Management	91495
Composites (old)	67507	Environmental Toxicology	91324
Computational Mathematics and Physics	33490	Epidemiology and Disease Control	91480
Computational Physics	68406	Eukaryotic Microbiology	91352
Computer Modelling of Physical Systems	68553	Evaluating Occupational Health and Safety (Construction Industry)	69336
Computing and Mathematics for Science	33290	Experimental Design and Methods	91440
Computing for Groundwater Specialists	49550	Experimental Design in Ecology	91303
Computing for Science	31871	Exploration and Mining Geology	66601
Contaminated Site Management	66025	Exploration Geochemistry	66504
Contemporary China	976111	Exploration Geophysics	66406
Convergent Margin Tectonics (Honours)	66651	Extractive Metallurgy	65062
Coordination and Organometallic Chemistry	65704	Field Methods in Ecotoxicology	91470
Coordination and Organometallic Chemistry (Advanced)	65754	Field Project	66604
Corrosion and Degradation of Materials	67606	Field Studies 1	66204
Corrosion Science	65705	Field Studies: Marine Sciences	91375
Crustal and Mantle Processes	66508	Field Studies: Mountain Ecology	91371
Current Topics in Clinical Microbiology	91481	Field Studies: Semi-arid Ecology	91370
Current Urban and Environmental Issues A	91280	Field Theory	68502
Current Urban and Environmental Issues B	91281	Fire and Explosion Investigation	65742
Current Urban and Environmental Issues C	91282	Fire Investigation	65758
Cytopathology	91377	First Aid Certificate Course	99536
Data Analysis in Occupational Health and Safety	69325	Fold Belts and Cratons	66305
Design and Selection of Materials	67605	Forensic Examination of Physical Evidence 1	65556
Device Physics	68652	Forensic Examination of Physical Evidence 2	65656
Diagnostic Bacteriology	91454	Forensic Examination of Physical Evidence 3	65756
Disease States	99585	Forensic Imaging	65341
Earth Materials	66304	Forensic Research Project	65856
Earth Resources	66408	Forensic Toxicology 1 (new)	65542
Earth Science 1	66101	Forensic Toxicology 1 (old)	65557
Earth Systems and the Environment	66062	Forensic Toxicology 2 (new)	65642
Ecological Modelling	91318	Forensic Toxicology 2 (old)	65657
Ecological Sampling	91329	Fossil Fuels	66503
Economic Geology	66403	Fossil Fuels (Honours)	66553
Economics of Coastal Resources	91478	Foundations of Helping and Caring	92167
Ecosystem Assessment	91494	Foundations of TCM	99502
Ecotoxicology Project (F/T)	91497		
Ecotoxicology Project (P/T)	91496		
Electrochemistry	65403		

Geochemistry	66303	Independent Research Project (Postgraduate)	99537
Geological Mapping	66201	Individual Project P/G – Life Sciences	91499
Geological Resources	98716	Individual Project – Life Sciences	91399
Geophysics	66510	Individual Research Project – Clinical Biochemistry F/T	91466
Geophysics and Remote Sensing of Groundwater Resources	66016	Individual Research Project – Clinical Biochemistry P/T	91458
Geopollution Management	66017	Industrial Ceramics	67306
GIS and Resources Assessment	98705	Industrial Metallurgy	67408
Graduate Clinic Internship (CHM)	99597	Industrial Training (Applied Chemistry Honours)	65995
Graduate Clinic Level 1 (CHM)	99600	Industrial Training (Applied Chemistry) P/T	65998
Graduate Clinic Level 2 (CHM)	99604	Industrial Training (Applied Geology) P/T	66998
Graduate Clinic Level 3 (TCM)	99595	Industrial Training (Honours)	66995
Groundwater Computing	49554	Industrial Training (Honours)	67995
Groundwater Engineering Projects (GD) F/T, P/T	44153, 44157	Industrial Training (Materials Science) P/T	67998
Groundwater Engineering Projects (M) F/T, P/T	44152, 44156	Industrial Training 1 (Applied Chemistry)	65996
Groundwater Geology	66034	Industrial Training 1 (Applied Geology)	66996
Groundwater Geophysics	66018	Industrial Training 1 (Applied Physics Honours)	68995
Groundwater Modelling	49555	Industrial Training 1 (Physics)	68996
Groundwater Science Projects (GD) F/T, P/T	66022, 66024	Industrial Training 1 (Materials Science)	67996
Groundwater Science Projects (M) F/T, P/T	66021, 66023	Industrial Training 2 (Applied Chemistry)	65997
Haematology 1	91355	Industrial Training 2 (Applied Geology)	66997
Haematology 2	91358	Industrial Training 2 (Materials Science)	67997
Health Sciences 1	99563	Industrial Training 2 (Physics)	68997
Health Sciences 2	99570	Industrial Waste Minimisation	49123
Herbal Prescriptions	99605	Inorganic Chemistry	65302
History and Philosophy of TCM	99511	Inorganic Chemistry 1 (Transition Metal Chemistry)	65411
Honours (Biological and Biomedical Sciences)	91304	Inorganic Chemistry 2 (New Inorganic Materials)	65509
Honours (Biological and Biomedical Sciences) (2yrs)	91305	Instrumentation for Materials Scientists	67410
Honours (Chemistry)	65854	Introduction to Biological Fluids	91382
Honours (Environmental Science)	66855	Introduction to Botany	99566
Honours (Geoscience)	66854	Introduction to Chinese Herbal Medicine	99567
Honours (Materials Science)	67854	Introduction to Ecotoxicology	91468
Honours (Physics)	68854	Introduction to Materials	67101
Honours Project	67851	Introduction to Microcomputers	31870
Honours Project	99593	Introduction to TCM	99560
Honours Project Proposal	67751	Introduction to Traditional Acupuncture Theory	99548
Honours Research Project	65858	Introductory Marine Ecology	91333
Honours Seminar	65853	Laboratory Methods in Ecotoxicology	91469
Horticultural Financial Management	91229	Landscape Design	91230
Horticultural Production Management	91224	Learning in Science 1	028001
Horticulture 1	91231	Learning in Science 2	028002
Horticulture 2	91232	Legal Aspects of Occupational Health and Safety	69342
Hospital Training in China	99527	Lithology	66202
Human Factors/Ergonomic Design	69323	Mapping and Remote Sensing	66407
Human Parasitology and Mycology	91455	Mapping and Remote Sensing	91323
Hydrogeochemistry	66015	Master's Thesis (Applied Chemistry) F/T	65990
Hydrogeology	66014	Master's Thesis (Applied Chemistry) P/T	65991
Immunological Responses to Infection	91457	Master's Thesis (Applied Geology) F/T	66990
Immunology 1	91351	Master's Thesis (Applied Geology) P/T	66991
Immunology 2	91359		
In-country Study 1: China	977111		
In-country Study 2: China	978111		

## 176 ALPHABETICAL LIST OF SUBJECTS

Master's Thesis (Applied Physics) F/T	68990	Organic Chemistry 2 (Structure	
Master's Thesis (Applied Physics) P/T	68991	Elucidation and Synthesis)	65508
Master's Thesis (Biol and Biomed) F/T	91777	Organisational Behaviour and	
Master's Thesis (Biol and Biomed) P/T	91778	Communication	69313
Master's Thesis (Materials Science) F/T	67990	Pathophysiology 1	91520
Master's Thesis (Materials Science) P/T	67991	Pathophysiology 1 (TCM)	99539
Master's Project – Traditional		Pathophysiology 2	91521
Chinese Medicine – P/T	99598	Pathophysiology 2 (TCM)	99540
Materials Engineering 1	67021	People and the Physical Environment	69335
Materials Engineering 2	67061	Pharmacognosy	99580
Materials Physics	68503	Pharmacology 1	91707
Materials Physics S	68753	Pharmacology 2	91709
Materials Science 1	67201	PhD Thesis (Biol and Biomed) F/T	91988
Materials Technology	67023	PhD Thesis (Biol and Biomed) P/T	91987
Mathematical Modelling 1	33130	Philosophy, Religion and Culture	99530
Mathematical Modelling 2	33230	Physical Chemistry 1	65307
Mathematical Modelling for Science	33190	Physical Chemistry 2	65607
Mathematics 1 (Life Sciences)	33101	Physical Evidence 1	65541
Mathematics and Scientific Software	33390	Physical Evidence 2	65641
Mechanical Properties of Materials	67303	Physical Mathematics	33330
Medical Devices and Diagnostics	91705	Physical Metallurgy	67304
Medical Science 1	91701	Physical Modelling	68036
Medical Science 2	91702	Physical Optics	68602
Meeting Special Needs in the		Physical Properties of Materials	67407
Secondary School	023002	Physics 1A	68041
Metallurgical Chemistry	65703	Physics 1C	68101
Metallurgical Chemistry (Advanced)	65753	Physics 1S	68711
Microbiology 1	91314	Physics 2	68201
Microbiology 2	91330	Physics 2 S	68721
Microbiology 3	91331	Physics 3	68311
Microprocessors in Instrumentation	68504	Physics 4	68411
Microprocessors in Instrumentation S	68754	Physics for Electronics S	68713
Microsystems	99578	Physiological Foundations of Health 1	91518
Mineral Deposits	66606	Physiological Foundations of Health 2	91519
Mineral Science Project	66608	Physiological Systems	91703
Mineralogy and Petrology	66301	Plant Genetics and Breeding	91271
Modern Standard Chinese Language		Plant Pathology	91237
and Culture	97x101	Plant Physiology	91270
Modernisation and Social Change	50140	Plant Production	91206
Molecular Biology 1	91332	Plant Production and Growth Media	91233
Molecular Biology 2	91335	Plant Tissue Culture	91236
Molecular Microbiology	91488	Plants in the Landscape	91207
Narcotics and Drugs of Abuse	65757	Point Location	99549
Neuroscience	91706	Point Location 1 (and Treatment Techniques)	99565
Nuclear Physics	68501	Pollution Assessment	98718
Nuclear Physics S	68751	Polymer Science	67305
Nutrition in a Traditional Chinese Medical		Polymer Technology	67409
Context	99535	Practice Management	99591
Occupational Hazard Analysis	69312	Principles and Practice of Biotechnology	91325
Occupational Health and Safety in Society	69311	Principles of Botany	99601
Occupational Health and Safety		Principles of Chinese Herbal Medicine	99599
Management	69343	Principles of Clinical Biochemistry	91410
Occupational Health and Safety Project	69351	Principles of Forensic Science	65241
Occupational Health Services	69334	Principles of Instrumentation	68604
Open Space Management	91225	Principles of Instrumentation S	68764
Organic Chemistry 1	65202	Principles of Pharmacognosy	99602
Organic Chemistry 2 (old)	65402	Professional Experience (Biol/Biom) F/T	91997
		Professional Experience (Biol/Biom) P/T	91999

Professional Writing and Communication	51389	Special Points and Systems	99509
Project (Honours)	66858	Special Reading Assignment P/G –	
Project (Honours)	68858	Life Sciences	91498
Project 1 (Chemistry)	65851	Special Reading Assignment – Life Sciences	91398
Project 2 (Chemistry)	65852	Special Topics in TCM (Intermodal and	
Project A	68508	Professional)	99590
Project B	68608	Spectroscopy and Structure	65301
Project Seminar	66507	Statistical Design and Analysis	33106
Project Workshops	99517	Statistics in Bioscience	91474
Psychology of Secondary Students	023001	Structural Geology	66402
Psychophysiology	91708	Surface Chemistry	65603
Public Administration and Management	98703	Surface Hydrology and Groundwater	49551
<i>Qi Gong</i> : Its Use in Acupuncture	99543	Surface Properties of Materials	67602
Quantum and Solid State Physics	68511	Surficial Processes and Products	66409
Quantum Physics 1	68401	Systems View of Life, A	99529
Quantum Physics 1 S	68741	Technical Ceramics	67506
Quantum Physics 2	68601	Technical Communication	51357
Quantum Physics 2 S	68761	Techniques of Materials Analysis	68516
Reaction Kinetics	65602	Technology and Innovation Forum	68515
Remote Sensing	66603	Technology, Society and Change	95556
Research Developments in Geoscience	66654	Tectonics	66602
Research Methodology – Medical		Tectonics and Surface Dynamics	66509
Microbiology	91487	Terrestrial Ecosystems	91306
Research Methods 1	91607	The Chinese Medical Approach to Health	
Research Methods 2	91608	and Disease	99551
Research Project – Medical		The Chinese Model of <i>Qi</i> and its Pathways	99552
Microbiology F/T	91492	The Physiology of <i>Qi</i>	99564
Research Project – Medical		The Subtle Dimensions of Healing	99531
Microbiology P/T	91491	Therapeutic Techniques and <i>Tuina</i>	
Research Proposal (Occupational Health		(Chinese Massage)	99555
and Safety)	69353	Thermodynamics	65031
Research Workshops 1	99550	Thermodynamics and Energy	68403
Research Workshops 2	99556	Thermodynamics and Energy S	68743
Resource Management	66404	Topics in Coastal Management	98707
Risk Assessment and Management	98708	Tourism, Recreation and Protected Area	
Risk Management	69341	Management	98719
Science Mathematics 1	33171	Toxic Materials in the Environment	91347
Science Mathematics 2	33172	Transducers and Devices	68605
Science Mathematics 3	33173	Transfusion Science	91340
Secondary Practicum 1	023191	Treatment of Scientific Data	60301
Secondary Practicum 2	023192	Undergraduate Research Project	91283
Sedimentary Geology	66302	Urban Stormwater Management	98709
Social Bases of Education	023502	Uses of Australian Plants	91234
Social Crisis	99532	Vacuum and Thin Film Physics	68405
Solid-state Physics	68505	Water Quality Management	49124
Solid-state Physics S	68755	Written and Oral Reporting	51368

# **Boards and committees**

---

## **FACULTY BOARD IN SCIENCE**

### **Ex officio members**

Dean of the Faculty  
 Professor A R Moon (Chair)  
 Associate Dean (Coursework Programs)  
 Associate Professor R T Buckney  
 Associate Dean (Research)  
 Professor E C Leitch  
 Faculty Administrator  
 Ms H M Juillerat  
 Faculty Technical Manager  
 Mr D Edwards  
 Head, Department of Applied Physics  
 Ms S W Hogg  
 Head, Department of Cell and Molecular Biology  
 Associate Professor K Broady  
 Head, Department of Chemistry, Materials and Forensic Science  
 Professor M A Wilson  
 Head, Department of Environmental Sciences  
 Associate Professor C G Skilbeck  
 Head, Department of Health Sciences  
 Associate Professor P Miller

### **Professors**

Professor A Johnson  
 Professor R L Raison  
 Professor G B Smith

### **Nominated members**

Dr S C Beecham  
 Faculty of Engineering  
 Dr T Langtry  
 Faculty of Mathematical and Computing Sciences  
 Ms J Forbes  
 Faculty of Nursing  
 Associate Professor E Hazel  
 Centre for Learning and Teaching  
 Ms S Scholfield  
 University Library

### **Elected members**

#### **Academic staff**

Associate Professor K Brown  
 Dr G Caprarelli  
 Dr D Cobbin  
 Dr K Cordatos  
 Ms L Evans  
 Dr E Frankel  
 Dr A George  
 Dr D C Green  
 Dr G Heness  
 Dr K Johnson  
 Associate Professor P F Logan  
 Dr R McConchie  
 Dr D Morrison  
 Ms A Pulkownik  
 Dr P Ralph  
 Associate Professor C Rogers  
 Dr A Simpson  
 Dr R Sleet  
 Dr I Stevenson  
 Dr J Swann  
 Dr J Tarran  
 Dr W Y Yeung

#### **Support staff**

Mr A Barnes  
 Mr A Buttenshaw  
 Mrs G Goldsack  
 Mr R Hayes  
 Mr J Phillips  
 Mr M Rosenbaum  
 Mr A Rubel  
 Ms M Stevens

#### **Student members**

Mr B Goeldi  
 Mr S King  
 Mr S Whitfield  
 Vacant

#### **Appointed members**

Professor M J Knight

## COURSE ADVISORY COMMITTEES

### Aim of the Course Advisory Committees

The Course Advisory Committees are Faculty-based committees whose aim is to provide a link between the Faculty, its Departments, professional bodies, industry, commerce and graduates. It is anticipated that these committees will assist the Faculty by offering advice on relevance and appropriateness of the Faculty's courses and alert the Faculty to current and future trends in industry and in the professions. Members of these committees provide advice and counsel to the Faculty for a variety of purposes, including Faculty Developmental Reviews, reviews by AVCC standards panels and accreditation of courses by professional associations.

### Composition of the Course Advisory Committees

Course Advisory Committees in the Faculty of Science usually have a majority of members external to the Faculty, normally including the following:

- a Chairperson external to the University who is eminent in the field
- the Dean of the Faculty
- the Head of the relevant Department
- one or more staff members of the Department
- external members from business and/or industry, professional associations and recent graduates of the Faculty.

### Terms of Reference for the Course Advisory Committees

- To consider and make recommendations to the Dean on any matters referred to it by the Vice-Chancellor, Faculty Board, the Dean, Associate Deans or the Head of Department.
- To examine course planning documentation for the review of an existing course as well as new courses planned for introduction by the Department (or multidisciplinary group). The committee must meet at least once prior to the course planning documentation being presented to Faculty Board. The committee is required to assess the proposal and to provide comments and advice on the Faculty's

proposed course of action and approach. Minutes of the meetings of the advisory committee should be forward with a letter from the Chair and incorporated in the documentation submitted to Faculty Board.

- To examine course accreditation documentation for the review of an existing course as well as new courses planned for introduction by the Department (or multidisciplinary group). The committee must meet at least once prior to the course accreditation documentation being presented to Faculty Board. The committee should examine and comment upon the proposals. This need not necessarily involve a detailed look at the curriculum, but the committee could consider matters such as objectives, balance and appropriateness of the proposed student outcomes. Minutes of the meetings of the advisory committee should be forwarded with a letter from the Chair and incorporated in the documentation submitted to Faculty Board.
- To examine and comment on all proposed major changes to existing courses. Minutes of the meetings of the advisory committee should be forwarded with a letter from the Chair and incorporated in the course planning document submitted to Faculty Board.

In addition, advisory committees are expected to report on the following:

- the Department's place in the profession(s);
- future developments within the Department and potential impact of strategic plans on the Faculty;
- adequacy of resources supplied by the University to the Department (needs versus supply);
- value, nature and scope of the professional experience component (if any) of the Department's courses;
- admissions and enrolment policies and practice of the Department;
- graduation rates in the Department;
- any other matters as appropriate.

In the case of a multidisciplinary course, the terms of reference are to be adapted to refer to the course's impact on the professions(s), the Faculty's strategic plan, resources, policies, admission and enrolment practices, graduation rates and any other matters as deemed appropriate.



### **Course Advisory Committee in Applied Chemistry – Forensic Science**

#### **Internal members**

Professor A R Moon  
Dean, Faculty of Science  
Associate Professor R T Buckney  
Associate Dean (Coursework Programs)  
Professor M A Wilson  
Head, Department of Chemistry, Materials  
and Forensic Science  
Dr C Roux  
Course Coordinator – Forensic Science  
Department of Chemistry, Materials and  
Forensic Science

#### **External members**

Dr E Crematy  
Division of Analytical Laboratories  
Mr A E Hodda  
Deputy Director, Division of Analytical  
Laboratories, The Institute of Clinical  
Pathology & Medical Research (ICPMR)  
Dr C J Lennard  
Director, Scientific Unit, Forensic Services,  
Australian Federal Police  
Dr M A Raymond  
Director, Forensic Services Group,  
New South Wales Police Services  
Dr J Robertson  
Assistant Secretary, Forensic Sciences  
Division, Australian Federal Police  
Dr A Ross  
Director, National Institute of Forensic  
Science  
Mr Z Skopec  
Director, Australian Forensic Drug  
Laboratory (AFDL)

### **Course Advisory Committee in Cell and Molecular Biology**

#### **Internal members**

Professor A R Moon  
Dean, Faculty of Science  
Associate Professor R T Buckney  
Associate Dean (Coursework Programs)  
Associate Professor K Broady  
Head of Department

#### **External members**

Dr C Bunn  
Principal Research Scientist, Biotech  
Australia  
Mr L Chia  
Regional Customer Support Manager,  
Abbott Diagnostics Division  
Dr A Field  
Deputy Director and Senior Staff Specialist,  
Department of Anatomical Pathology, St  
Vincent's Hospital  
Dr A Fletcher  
Head, Department of Cell Biology, Red Cross  
Blood Transfusion Service  
Dr K Hopper  
Director, Aoris Nova Pty Ltd  
Dr J Isbister  
Head, Department of Haematology, Royal  
North Shore Hospital  
Dr M Meerkin  
Chief Executive Officer and Managing  
Pathologist, Sugerman's Pathology Pty Ltd  
Dr P Molloy  
Research Scientist, CSIRO Division of  
Biomolecular Engineering  
Associate Professor D Naidoo  
Director of Clinical Chemistry, The Prince of  
Wales Hospital  
Dr R Pritchard  
Head, Department of Microbiology, Royal  
North Shore Hospital

## Course Advisory Committee in Chemistry

### Internal members

Professor A R Moon  
Dean, Faculty of Science  
Associate Professor R T Buckney  
Associate Dean (Coursework Programs)  
Professor M A Wilson  
Head of Department  
Associate Professor A T Baker  
Associate Professor G P Norton  
Associate Professors in Chemistry

### External members

Dr G Batley  
Chief Research Scientist, Centre for  
Advanced Analytical Chemistry, CSIRO  
Division of Coal and Energy Technology  
Dr J Crass  
Laboratory Technology and Food Processing,  
Bankstown College of TAFE  
Mr G Livanos  
QA Manager, Stafford Miller  
Dr F Mitchell  
Asset Management, TransGrid  
Mr R Mooney  
AMDEL Laboratories Ltd  
Mr G Paul  
Hardman Australia  
Mr D Waters  
Manager, SPECT Production, National  
Medical Cyclotron, ANSTO

## Course Advisory Committee in Environmental Biology and Horticulture

### Internal members

Professor A R Moon  
Dean, Faculty of Science  
Associate Professor R T Buckney  
Associate Dean (Coursework Programs)  
Associate Professor C G Skilbeck  
Head of Department  
Associate Professor K Brown  
Associate Professor in Environmental  
Biology  
Dr D Morrison  
Senior Lecturer  
Mr J Renwick  
Lecturer

Dr K Johnson  
Lecturer  
Ms A Pulkownik  
Lecturer

### External members

Associate Professor P Adam  
School of Biology, University of New South  
Wales  
Ms L Brodie  
Bushland Management Officer,  
National Trust of Australia (NSW)  
Mr N I Crowe  
Proprietor, Berrima Bridge Nursery  
Dr C Grant  
Executive Director, Environment, Planning  
and Estate Management, Olympic  
Coordination Authority  
Mr R Grimwade  
Director, Centennial Park and Moore Park  
Trust

## Course Advisory Committee in Geology

### Internal members

Professor A R Moon  
Dean, Faculty of Science  
Associate Professor R T Buckney  
Associate Dean (Coursework Programs)  
Associate Professor G Skilbeck  
Head of Department

### External members

Dr A S Andrew, Principal Research Scientist  
CSIRO, Division of Petroleum Resources  
Dr A R Collins  
Consultant  
Mr J N Cramsie  
Director, Geological Survey NSW,  
Department of Mineral Resources  
Mr R N Lees  
Managing Director, Michelago Resources  
N.L.  
Mr M Smith  
General Manager, Exploration, Austpac Gold  
N.L.  
Mr P Southwell  
Chief Geoscientist, Exploration Department,  
Cultus Petroleum

## **Course Advisory Committee in Health Sciences**

### **Internal members**

Professor A R Moon  
Dean, Faculty of Science  
Associate Professor R T Buckney  
Associate Dean (Coursework Programs)  
Associate Professor P Miller  
Head of Department

### **External members**

Ms C Berle  
Traditional Acupuncturist, Chair, National  
Acupuncture Branch, Australian Natural  
Therapists Association  
Associate Professor J Duke  
Faculty of Nursing, Royal Melbourne  
Institute of Technology  
Ms V Ibbotson  
Clinical Nurse Consultant, HIV/Infection  
Control, Department of Microbiology, Royal  
North Shore Hospital  
Dr L Oliver  
Chief Physicist, Department of Clinical  
Oncology, Royal North Shore Hospital  
Dr K Watson  
Senior Lecturer, Acupuncture Course  
Coordinator, Victoria University of  
Technology

## **Course Advisory Committee in Materials Science**

### **Internal members**

Professor A R Moon  
Dean, Faculty of Science  
Associate Professor R T Buckney  
Associate Dean (Coursework Programs)  
Professor M A Wilson  
Head of Department  
Dr A Ray

### **External members**

Dr P Bryant  
Thomson Marconi Sonar Pty Ltd  
Mr J Byrnes  
Consultant  
Dr R Grant (Chair)  
Development Chemist, Dow Corning  
Australia Pty Ltd

Mr I Johnson  
Marketing Development Manager, ICI  
Ms J Liston  
Principal Packaging Technologist, Unifoods  
Dr D Taylor  
Managing Director, Taylor Ceramic  
Engineering

## **Course Advisory Committee in Occupational Health and Safety**

### **Internal members**

Professor A R Moon  
Dean, Faculty of Science  
Associate Professor R T Buckney  
Associate Dean (Coursework Programs)  
Associate Professor P Miller  
Head of Department  
Dr D Cobbin  
Senior Lecturer

### **External members**

Mr G Douglas  
Coordinator, OH&S Education Unit,  
Workcover Authority of NSW  
Dr B Emerson  
Member Federal Safety Education  
Committee, Safety Institute of Australia  
Mrs C Kellehear  
Senior Occupational Health Nurse Adviser,  
Workcover Authority of NSW  
Ms S Kidziak  
Principal Consultant Occupational Health,  
Safety and Environment, Chamber of  
Manufacturers of NSW  
Ms D Nalty  
Rehabilitation Coordinator, Catholic Schools  
Office

## Course Advisory Committee in Physics

### Internal members

Professor A R Moon  
Dean, Faculty of Science  
Associate Professor R T Buckney  
Associate Dean (Coursework Programs)  
Ms S W Hogg  
Head of Department  
Professor G B Smith  
Professor of Applied Physics

### External members

Mr N Crothers  
Technical Development Manager, Australian  
Consumers' Association  
Dr P Dermody  
Consultant  
Mr B Hutton  
Head, Diagnostic Physics Group,  
Department of Nuclear Medicine, Westmead  
Hospital  
Professor A Samarin, FTS  
Consultant  
Dr M Swain  
Senior Principal Research Officer, CSIRO  
Division of Applied Physics  
Dr J Warner  
Fund Manager, First State Managed  
Investments

## Advisory Board of the Institute for Coastal Resource Management

### Internal members

Associate Professor K Brown  
Director, Institute for Coastal Resource  
Management  
Associate Professor R T Buckney  
Associate Dean (Coursework Programs),  
Faculty of Science  
Professor R Robertson  
Dean, Faculty of Business  
Dr I Frank  
Director, International Programs  
Mr C Farmer  
Project Manager (Acting),  
Institute for Coastal Research Management  
Mr S Wearing  
Senior Lecturer, School of Leisure and  
Tourism, Faculty of Business

### External members

Dr G Batley  
Manager, CSIRO  
Cr R Bell  
Gosford City Council Representative  
Mr M Channell  
Sydney Coastal Councils  
Dr P Fagan  
Environment Projects Manager, AWT  
Mr L Franklin  
Director of Planning and Development,  
NSW Tourism Commission  
Mr P Mahoney  
Environment Section,  
Roads and Traffic Authority  
Mr J Parsons  
AWT Ensign  
Mr R Pierson  
Natural Resources Policy Unit,  
NSW Department of Planning  
Ms B Richardson  
Policy Manager,  
Environment Protection Authority  
Mr J Tainish  
Coastal Engineering Branch,  
Department of Land and Water  
Conservation  
Ms J Wall  
Office of Marine Safety and Port Strategy,  
Sydney Ports Corporation

# Staff list

---

*Professor of Physics and Dean of Science*  
A R Moon, BSc, PhD (Melb), FAIP

*Professor of Geology and Associate Dean (Research)*

E C Leitch, MSc (Auck), PhD (UNE), FGS

*Associate Professor and Associate Dean (Coursework Programs)*

R T Buckney, BSc (Hons), PhD (Tas), MAIBiol

*Executive Administrative Assistant to the Dean*  
C A Crane

*Executive Administrative Assistant to the Associate Dean (Coursework Programs)*

G L Angus

*Executive Administrative Assistant to the Associate Dean (Research)*

D Pratt, BEd (Adult Ed) (UTS)

*Faculty Administrator*

H M Juillerat, BEc, LLB (Q'ld)

*Administrative Officers*

C H Crammond, BSc (Arch) (UNSW)

B J Kitto, BA (Macq)

D A R Tudge

M A Stevens, BAppSc (UTS)

*Administrative Assistant*

D K Lowe, BA (Macq), GradDipSocSc (UNE)

## Microstructural Analysis Unit

*Director*

M Phillips, BSc (UNSW), PhD (UTS), GAIP

*Research Fellow*

M Stevens-Kalceff, BSc (ANU), PhD (UNSW), MAIP

*Scientific Officer, X-ray Facility*

M Berkhan BAppSc (UTS)

*Scientific Officer, EM Facility*

R Wuhrer, MAppSc (UTS)

## Faculty Technical Staff

*Faculty Technical Manager*

D Edwards, E & C Cert

*Technical Manager (City campus)*

B Robens, BSc, PostGradDipHumComm, MEngSc (UNSW), MgmtCert (AIM), GIEA, AAIM, MACEA

*Scientific Officers, Computing Support*

A T Stafford, MA (Cantab)

A Watts

*Project Engineer*

R W Peters, DipTech (Mech Eng), BE (NSWIT)

*Services/Stores Officer (St Leonards)*  
E Soliman

## Mechanical Workshop

*Manager*

C Lidster

*Senior Laboratory Craftspersons*

J Edgington

P J Fanos

## Electronic Workshop (St Leonards)

*Manager*

J J Stafford

## Department of Applied Physics

*Senior Lecturer and Head of Department*

S W Hogg, BSc (UWA), MAppSc (NSWIT), MAIP

*Professor of Applied Physics*

G B Smith, BSc (UNE), PhD (Monash), FAIP

*Professor of Physics*

A R Moon, BSc, PhD (Melb), FAIP

*Associate Professors*

R W Cheary, BSc, PhD (Aston)

L Kirkup, BSc (Sheff), MSc (Lond), PhD (Pais), MInstP, CPhys, MAIP

P F Logan, MSc (Syd), PhD (ANU), GradDipEdStud (ACAE), MInstP

*Senior Lecturers*

G R Anstis, BSc (Monash), PhD (Adel), MAIP

M Braun, BSc (Melb), MAppSc (QIT), PhD (Flin), MACPSEM, MIEEE, MIPEMB

D C Green, BSc (Q'ld), PhD (Syd), MAIP

W Kalceff, BSc (Syd), PhD (UNSW), DipEd (Syd Teach Coll), MAIP

K McGuffie, BSc (Edin), PhD (Liv), FRMetS, MAGU

*Lecturers*

A C Fischer-Cripps, BAppSci (UTS), PhD (Syd)

J Schulte, MSc (Darmstadt), DSc (Oldenburg)

P Swift, BSc (Tas), PhD (Syd)

R L S Woolcott, BSc, PhD (Syd), MAIP

*Research Fellows*

F Jahan, BSc MSc (Rajsh), PhD (Brun)

A V Radchik, BSc, PhD (Odessa)

A J Reuben, BA (Syd), MAppSc, PhD (UTS)

*Honorary Associate*

E P A Sullivan, MSc, PhD (Syd), MAIP

*Research Assistants*

J Franklin  
A Searle  
W Yan

*Department Administrative Assistant*

E Coultie

*Technical Manager*

M Rosenbaum, DipMechEng (ACME-CSSR),  
VTC Cert (AIEA)

*Senior Technical Officers*

R Graves, E&C Cert  
G McCredie  
G Stockton, BAppSc (NSWIT), DipEd  
(KCAE)  
A Wong

*Technical Officers*

N Maharaj, BEd (UNE), DipEd (USP - Fiji),  
M T Smith

*Laboratory Cleaner*

C Withycombe

## Department of Cell and Molecular Biology

*Associate Professor and Head of Department*

K W Broady, BSc (Hons), PhD (UNSW),  
MASM

*Professor of Immunology*

R L Raison, BSc (Syd), PhD (Monash),  
FAIBiol

*Professor of Microbiology*

A M Johnson, BAppSc (SAIT), MEdMgmt,  
PhD (Flin), MA (Hons), DSc (W'gong),  
FASM, FAIBiol

*Senior Lecturers*

J T Ellis, BSc (Hons) (Reading), PhD (Liv)  
A M George, MSc, PhD (Syd)  
L F Gibson, BSc (Hons) (Edin), PhD (Melb),  
FASM, MAIBiol  
A D Kidman, BSc (Syd), MSc (UNSW), PhD  
(Hawaii), MAPsS  
R L Orwell, BSc, PhD (UNSW)  
A A Piper, BSc (Hons) (Monash), DPhil (Oxf)  
A M Simpson, BSc (Hons), PhD (Syd)  
I M Stevenson, BSc (Birm), PhD (Edin),  
FASM, MAIBiol  
J C Swann, BSc, PhD (Adel)

*Lecturers*

H J Buys, BSc (Hons) (Capetown), MSc  
(UNSW)  
L F Chew, MSc (UNSW)  
K Cordatos, BSc, DipEd (Syd), MEd (UNE),  
GradDipTertEd (UNSW), CT (ASC), CFIAC  
M W Davey, BSc (Q'ld), PhD (ANU)  
N C Smith, BSc (Hons), PhD (ANU)

T Szynda, MSc, PhD (Melb), MASEP,  
MAFSS

N B Woodland, BSc (UNE)

*Adjunct Professors*

J Isbister, BSc (Med) (Hons), MB BS Hons  
(UNSW), FRACP, FRCPA

M Meerkin, BSc (Melb), MB BS (Monash),  
FRCPA, FAACB, FACB

*Honorary Associates*

G Grohmann, BSc (Hons) (UNSW), PhD  
(Syd)

R Munro, MB BS (Syd), MRCP, FRCPath,  
FRCPA, DpBact, FASM

K Robinson, BSc (Hons), PhD (Witw)

J Walker, MSc, PhD (Syd)

*Department Administrative Assistant*

J Tang

*Laboratory Managers*

W Booth, BSc (Q'ld), MAppSc (QUT), PhD  
(Syd) – Biochemistry

J Phillips, BSc (UNSW), MASM, MAIBiol

*Senior Technical Officer*

J Khoury, BAppSc (NSWIT), MASM,  
MAIBiol

*Technical Officers*

T Baragith

L Kwon, BSc (UNSW)

V Statzenko, BiolCert (STC)

V Taylor-Perkins, BioTechPathCert (TAFE)

J Thorpe

Z Winlarski, MSc (UJ, Krakow)

*Laboratory Cleaner*

O Petroff

## Immunobiology Unit

*Professor and Head of Unit*

R L Raison, BSc (Syd), PhD (Monash),  
FAIBiol

*Associate Professor*

K W Broady, BSc (Hons), PhD (UNSW),  
MASM

*Lecturer*

N C Smith, BSc (Hons), PhD (ANU)

*Scientific Officer and Laboratory Manager*

K Weston, BSc (Hons) (Syd), PhD (UTS)

*Senior Research Associate*

A Tseng, BSc (Portland), MAppSc, PhD  
(UNSW)

*Research Associate*

R Dunn, BSc (Hons) (Capetown), MSc  
(Natal), PhD (Syd)

*Research Assistants*

M Burandt, BSc (Hons) (UTS)

J Moses, BSc (Hons) (UNSW)

M Padula, BSc (Hons) (Macq)  
S Sekulowski, BSc (Hons) (Lond)

*Technical Officer*  
D Jones, BSc (Syd)

### **Molecular Parasitology Unit**

*Professor and Head of Unit*  
A M Johnson, BAppSc (SAIT), MEdMgmt,  
PhD (Flin), MA (Hons), DSc (W'gong) FASM,  
FAIBiol

*Senior Lecturers*  
J T Ellis, BSc (Reading), PhD (Liv)  
D A Morrison, BSc, PhD (Syd), MAIBiol

*Lecturer*  
N C Smith, BSc (Hons), PhD (ANU)

*Technical Officer and Laboratory Manager*  
M Johnson, BAppSc (UTS)

*Postdoctoral Fellows*  
N Beebe, BSc, DipClinBiochem (Griff), PhD  
(Q'ld)

K Miller, BSc (Hons), PhD (ANU)

*Research Assistants*  
N Amaro, BSc (Hons) (UTS)  
K Luton, BSc (Hons) (James Cook)  
C Ryce, BSc (UNSW)

### **Molecular Genetics Unit**

*Senior Lecturers*  
A A Piper, BSc (Hons) (Monash), DPhil (Oxf)  
A M George, MSc, PhD (Syd)  
A M Simpson, BSc (Hons), PhD (Syd)

*Lecturers*  
M W Davey, BSc (Q'ld), PhD (ANU)  
R McConchie, BSc (Lond), MA (Macq), PhD  
(Louis), MASPP, MAuSHS, MASHS

*Research Assistants*  
M Comacho, BSc (UC, San Diego)  
R Paulin, BSc (Hons) (Syd), MSc (Macq)

### **Psycho-oncology Unit**

*Senior Lecturer and Head of Unit*  
A D Kidman, BSc (Syd), MSc (UNSW), PhD  
(Hawaii), MAPsS

*Administrative Officer*  
J Harrop, RN Psych

*Administrative Assistant*  
V Usher

*Research Officers*  
S Edelman, BEc (Monash), DipEd, MA Psych  
(Syd)  
B Goodenough, BSc (Hons) (Psych) (UNSW),  
PhD (UNSW)  
K Pauncz, BA (Hons) (Psych) (UNSW)

## **Department of Chemistry, Materials and Forensic Science**

*Professor of Chemistry and Head of Department*  
M A Wilson, PhD, DSc (Auck), CChem,  
FRACI

*Associate Professors*  
A T Baker, BSc (Hons), PhD (UNSW),  
CChem, FRACI  
J P Byrne, BSc, PhD (Syd), CChem, MRACI  
R W Jones, BSc, DipEd (Melb), PhD (Cantab),  
CChem, MRACI  
G P Norton, BSc (Syd), PhD (UNSW),  
CChem, FRACI  
W Stern, BSc, PhD (UNSW), ASTC, CChem,  
FRACI

*Senior Lecturers*  
B Ben-Nissan, BSc (ITU), MSc, PhD (UNSW),  
MIMMA

M Dawson, BPharm, PhD (Syd), CChem,  
MRACI, MPS

A S Ray, BSc (Hons), MSc (Calc), PhD  
(UNSW), MIMMA  
R J Sleet, MSc, PhD (Syd), CChem, FRACI  
M G Stevens, MSc, PhD (Syd), MRACI  
M Wilson, BSc (N'cle), PhD (UNSW),  
MIEAust

W Y Yeung, BSc (Eng), PhD (HK), MIMMA,  
FRMS, MIM (UK), CPEng, CEng (UK)  
B R Young, BE, PhD (Cantuar), CPEng,  
MIEAust, CChem, MRACI

*Lecturers*  
C Conn, BSc, PhD (Melb)  
L A Evans, BAppSc (Hons) (NSWIT), PhD  
(Murd), CChem, MRACI  
G L Heness, BAppSc (NSWIT), MAppSc  
(UTS), PhD (Syd)  
J R Kalman, BSc, PhD (Syd), CChem, MRACI  
A K Mukerji, BE (Burdwan), MS, PhD  
(Illinois)

M Mulholland, BSc, PhD (UNSW)  
H Patney, MSc (Hons) (Punjab), PhD (Flin),  
CChem, MRACI  
B Stuart, BSc (Hons), MAppSc (Syd), PhD  
(Imperial College, Lond), DIC Chem  
C Roux, BSc, PhD (Lausanne), MFSS, MIAI  
P Thomas, BSc (Kings College, Lond), PhD  
(Imperial College, Lond), DIC  
R Ward, BSc (Syd), DipEd (CSturt), CChem  
MRACI

*Emeritus Professor*  
J Unsworth, BSc (Wales), MSc (UMIST), PhD  
(Macq), CChem, CPhys, FAIP, FPRI, SMIEEE

*Honorary Associates*

J K Crass, MAppSc (NSWIT), PhD (UTS)  
 W R Day, MSc (UNSW), ASTC, MRACI,  
 FAIFST  
 G M Renwick, BSc (St And), PhD (Monash),  
 MRACI, CChem

*ARC Research Fellow*

K Gross, BE (Hons)(Materials Eng), MEng  
 (Materials Eng) (Monash), PhD (New York  
 State)

*Postdoctoral Fellow*

M Lake, BSc (Hons), PhD (Syd), MAIP

*Department Administrative Assistant*

E Koirala

*Technical Manager*

B Robens, BSc, GradDipHumComm,  
 MEngSc (UNSW), MgmtCert (AIM), GIEA,  
 AAIM, MACEA

*Laboratory Manager*

A Rubel, BSc, MSc (MechEng) (Idaho)

*Scientific Officers*

N Booth, BAppSc (Materials Science) (UTS)  
 J P Guerbois, DipBuildMatSc (CNAM, Paris)  
 J Keegan, DipTech (Sc), BAppSc (NSWIT)

*Senior Technical Officers*

A Barnes  
 J Holmes  
 L Klemes, DipTech (Sc) (NSWIT)

*Technical Officers*

D Cohen, DipTech (Sc) (NSWIT)  
 M Daraphet  
 A Harris  
 G Grindrod, PathTechCert (STC),  
 AdvCertHort (Ryde TAFE), MAIH,  
 AssDipAppSc (Ryde TAFE)

*Research Scientists*

K Kannangara, BSc (Columbo), PhD  
 (Hawaii)  
 G Lee, BSc (Hons) PhD (UNSW)  
 O Lu, BSc, MSc (China), PhD (UNSW)  
 H R Rose, BSc, MSc (Moscow), PhD (UNSW)

*Laboratory Cleaner*

N Djordjevic

**Department of Environmental Sciences***Associate Professor and Head of Department*

C G Skilbeck, BSc (Hons), PhD (Syd), MAIG

*Professor of Geology*

E C Leitch, MSc (Auck), PhD (UNE), FGS

*Associate Professors*

K R Brown, BSc, PhD (UNSW), MAIBiol  
 R T Buckney, BSc (Hons), PhD (Tas), MAIBiol  
 D Cheng, BSc (Hons), TTC, PhD (Tas),  
 MASL, MAMSA, MFBA, MAIBiol

*Senior Lecturers*

D Booth, BSc (Hons) (Syd), MSc (Queens U),  
 PhD (Oregon State)  
 L F De Filippis, BSc (Hons), PhD (LaT),  
 MAIH  
 E Frankel, BSc (Natal), PhD (Syd)  
 R Lim, MSc (Mal), PhD (Wat), MAIBiol  
 D A Morrison, BSc, PhD (Syd), MAIBiol  
 J Tarran, BSc (Hons), DipEd, PhD (UNSW),  
 MAIH

*Lecturers*

B J Bloomfield, ASTC, BSc (UNSW), MSc  
 (Syd), PhD (Rutgers)  
 G Caprarelli, MSc, PhD, DipEngGeol (Rome)  
 K A Johnson, MScAgr (Acad Krakow), PhD  
 (UTS), MAIBiol, MAAIAS, MRACI  
 R McConchie, BSc (Lond), MA (Macq), PhD  
 (Louis), MASPP, MAuSHS, MASHS  
 U Munro, DipBiol (Frankfurt), PhD (UNE)  
 A Pulkownik, MSc (Syd)  
 P Ralph, BAppSc (NSWIT), MAIBiol, PhD  
 (UTS)  
 J Renwick, BAppSc (BiomedSc) (NSWIT)

*Associate Lecturer*

B B Dent, BSc (UNSW), GradDipEd (KCAE),  
 MSc (UTS), MIAH, MAIG

*Adjunct Professors*

M D Burchett, BSc, PhD (Syd), DipEd (UNE),  
 MAIBiol, FAIH  
 B J Franklin, BSc (Syd), PhD (UNSW), MAIG,  
 FGAA  
 B Marshall, BSc (Lond), PhD (Brist),  
 GradDipMgt (CIAE), ARCS, FGS, MAIMM,  
 MAIG

*Honorary Associates*

J Chapman, BSc (Hons) (UNSW), PhD (Syd),  
 DipEnvStud (Macq), MAIBiol  
 G Francis  
 R Goldsack, PhD (UNSW)  
 J Mercer, MSc (UNZ), PhD (Syd)  
 S R Sangameshwar, MSc (Mys), MSc, PhD  
 (Sask), FGS, MAIMM, MAIG, FGAC  
 F L Sutherland, MSc (Tas), PhD (James Cook)



*Honorary Research Associate*

M Ahsanullah, MSc (Karachi), PhD (Lond)

*Department Administrative Assistants*

J M Taverner

*Laboratory Managers*

G Goldsack, DipMedTech (AIMS), AAIMS, MAIBiol

N Richardson, DipMedTech (STC)

*Technical Manager*

A Buttenshaw, ChemCert, MetCert (TAFE)

*Senior Technical Officers*

S Fenech, BAppSc (NSWIT)

P Jones, TechCertBiol (SydTech), BAppSc (UTS)

*Technical Officers*

D Knezevic

J Dabovic, BAppSc (Hons) (CSturt)

A Giles, BAppSc (Hons) (NSWIT)

R Hungerford, BAppSc (Hons) (NSWIT)

L M Hunt, BAppSc (Hons) (NSWIT)

A Statzenko, BSc (Syd)

GradDipEnvStud(Macq)

C Wojak, BiolTechCert (STC)

*Research Assistants*

G MacFarlane, AssDipAppSci (Hunter IT), BSc (N'cle)

R Mousine, DipBiol (Tashkent), PhD (Moscow)

*Technical Assistant*

T Ye

**Department of Health Sciences***Associate Professor and Head of Department*

P F Miller, MSc, PhD (Man), DipTertiaryEd (UNE), MAIBiol

*Associate Professors*

A R Craig, BSc (Hons), PhD (UNSW), MAPsS, BMCP

L K Holley, BAppSc (DDIAE), MAppSc (QIT), PhD (Macq), DipLaw (BAB), MAIP, MACPSEM, MIEEE

C Rogers, BA (ICOM), DipAc, DSc (CP), LectAc (HKCCA), MACAc

*Senior Lecturers*

D M Cobbin, MSc, PhD (Syd), PhD (Macq), Tech Cert (William Balmain TC), MAPsS

G M Nicholson, BSc (Hons), PhD (Syd), MIST, MANS

*Lecturers*

D Edwards, BSc (Hons) (Syd), MAppSc (ClinBiochem) (UTS)

D K Martin, BOptom (Hons), MBiomedE, PhD (UNSW)

M J Wilson, MSc (UNSW), MASM

J R Wyndham, BSc, MSc, MPH DipEd (Syd), GCHE (UTS), MAIBiol, MPHA

C X Yang, DipAppSc (Biochem) (Swinburne), CertAdvAc (GCTCM), PracDipAc (ACA), MSc (UNSW), MACAc

C Zaslowski, BAppSc (Phy) (Syd), PracDipAc (ACA), CertAdvAc (GCTCM), DipChHerb (ACOM), MHLthScEd, MACAc  
S P Zhang, PhD, BMed (TCM)

*Associate Lecturers*

W Cochran, BA, DipTchg, DipTCM, CertAcu

M Garvey, BA (Syd), PracDipAc (ACA),

CertAdvAc (NCTCM), DipChMass (NC),

DipSwedMass (SydCChiro), MLitt (UNE), MACAc

*Department Administrative Assistant*

D Massey

*Administrative Officer*

R Hayes, AdvCertPblcAdmn (SydTech)

*Administrative Assistant*

S K Pan

*Laboratory Manager*

B Peters, BAppSc (NSWIT), Cert Urban Pest Control (Syd Tech), MAIBiol

*Clinic Managers*

P Meier

C L Zhou

*Technical Officers*

J Easton, BAppSc (NSWIT), CertSciPhotog, MSc (UTS)

D Kelly, PathTechCert (Syd Tech)

M Stasos, BSc (UNSW)

C Zappia, BAppSc (UTS)

*Senior Research Officer*

P McIssac, GAPS

*Doctoral Student and Senior Research Assistant*

K Hancock, BSc (Hons) (UNSW), MAPS

*Research Assistant*

J Bursill, BTC (Armidale TAFE)

## Centre for Biomedical Technology

*Associate Professor and Director*

H T Nguyen, ME, PhD (N'cle), FIEAust

### Faculty of Business

W Spinks, DipPhysEd (WTC), BEd (UWA), MA (Ed) (Macq), PhD (Syd)  
*(Senior Lecturer)*

### Faculty of Engineering

J Daba, BSc (Houston), MSc, PhD (Purdue)  
*(Lecturer)*

M Eckert, BSc (Tulane), MS, PhD (Penn)  
*(Lecturer)*

V McKain, BSc, BH MS (Ed) (Q'ld), BEng (QUT), MS (Penn State), GradDipTerEd (UTS)  
*(Associate Lecturer)*

G Murphy, BE (UTS)  
*(Engineer)*

S Y Shoon, BSc (Coll of Chinese Culture, Taiwan), MSc (Nat Taiwan IT)  
*(Engineer)*

### Faculty of Mathematical and Computing Sciences

W T Hung, BAppSc (NSWIT), MEngSc (UNSW), PhD (Macq), MASOR, AFIMA  
*(Postdoctoral Research Fellow)*

E Lidums, MSc (Syd)  
*(Lecturer)*

K Suffern, MSc (Monash), MSc (Cornell), PhD (Sydney), MACS  
*(Senior Lecturer)*

B S Thornton, FTS, PhD (UNSW), DSc (Syd), CPhys, CEng, FInstP, FBCS, FACS, FRAeS, FIEAust  
*(Professor)*

### Faculty of Nursing

J McGee, RN, BA MHPed  
*(Senior Lecturer)*

S McKinley, RN, BAppSci (Lincoln), PhD (LaT)  
*(Professor of Critical Care Nursing)*

S D Pelletier, RN, BScN (Tor), DipEd (Nursing) (SCAE), BEdSt (Q'ld), MScSoc (UNSW), MCN (NSW), FRCNA  
*(Senior Lecturer)*

## Faculty of Science

M Braun, BSc (Melb), MAppSc (QIT), PhD (Flin), MACPSEM, MIPEMB, MIEEE  
*(Senior Lecturer)*

K Cordatos, BSc, DipEd (Syd), MEd (UNE), Graduate Certificate in Higher Education (UTS), CTIAC, CT (ASC), MASC, CFIAC, AAIMS, MAIBiol  
*(Lecturer)*

L K Holley, BAppSc (DDIAE), MAppSc (QIT), PhD (Macq), DipLaw (BAB), MAIP, MACPSEM, MIEEE  
*(Associate Professor)*

L Kirkup, BSc (Sheff), MSc (Lond), PhD (Pais), MInstP, CPhys, MAIP  
*(Associate Professor)*

G M Nicholson, BSc (Hons), PhD (Syd), MIST, MANS  
*(Senior Lecturer)*

J Schulte, MSc (Darmstadt), DSc (Oldenburg)  
*(Lecturer)*

N B Woodland, BSc (UNE)  
*(Lecturer)*

### External Members

Mr S Valance,  
Chief Executive Officer, Medical Industry Association

Dr J Miller,  
Director, Medical and Scientific Affairs, Novo Nordisk Pty Ltd

### External Research Associates

Associate Professor Terry Campbell  
St Vincent's Hospital

Associate Professor Branko Celler  
University of New South Wales

Professor Francis Chan  
University of Hong Kong

Dr Brian Cleland  
Telectronic Pacing Systems

Dr Stephen Colaguiari  
Prince of Wales Hospital

Mr Stefan Eberl  
Royal Prince Alfred Hospital

Dr Jeff Flack  
Bankstown-Lidcombe Hospital

Mr Roger Fulton  
Royal Prince Alfred Hospital

Mr Romuald Gajewski  
Westmead Hospital

Mr Peter Hunt  
Royal North Shore Hospital

Mr Brian Hutton  
Westmead Hospital

Dr Hidehiro Iida  
Research Institute for Brain and Blood  
Vessels, Akita, Japan

Dr Iwao Kanno  
Research Institute for Brain and Blood  
Vessels, Akita, Japan

Professor Stephen Knisley  
University of Alabama, Birmingham, USA

Dr Nigel Lovell  
University of New South Wales

Dr Richard Ollerton  
University of Western Sydney

Dr Lyn Oliver  
Royal North Shore Hospital

Dr David Owens  
University of Wales College of Medicine

Dr Richard Smart  
St George Hospital

### Centre for Ecotoxicology

#### Joint UTS/Environment Protection Authority (EPA)

##### *Co-Director*

J Chapman, BSc (Hons) (UNSW), PhD (Syd),  
DipEnvStud (Macq), MAIBiol, MASE,  
MSETAC

##### *Ecotoxicologists*

R V Hyne, BSc (UWA), MSc, PhD (N'cle),  
MASE

M Julli, BAppSc (NSWIT), MAppSc (UTS),  
MASE

R Krassoi, BAppSc (UTS), MASE

F Pablo BSc, MSc (Phils), PhD (UWSN)

R Sunderam, BSc (Hons) (SLanka), MAppSc  
(UTS), MASE

M Warne, BSc (Hons) (N'cle), PhD (Griff),  
MRACI, MSETAC, MASE

##### *Co-Director*

M D Burchett, BSc, PhD (Syd), DipEd (UNE),  
MAIBiol, FAIH

##### *Professor*

R L Raison, BSc (Syd), PhD (Monash)

##### *Associate Professors*

R T Buckney, BSc (Hons), PhD (Tas), MAIBiol

P F Miller, MSc, PhD (Man), DipTertiaryEd  
(UNE), MAIBiol

##### *Senior Lecturers*

M Dawson, BPharm, PhD (Syd), CChem,  
MRACI, MPS

R Lim, MSc (Mal), PhD (Wat), MAIBiol

G M Nicholson, BSc (Hons), PhD (Syd)

R L Orwell, BSc, PhD (UNSW)

A A Piper, BSc (Hons) (Monash), DPhil (Oxf)

##### *Lecturers*

D Booth, BSc (Hons) (Syd), MSc (Queens U),  
PhD (Oregon State)

M Mulholland, BSc, PhD (UNSW)

A Pulkownik, MSc (Syd)

J Renwick, BAppSc (BiomedSc) (NSWIT)

##### *Administrative Officer*

J Monk

##### *Laboratory Manager*

N Richardson, DipMedTech (STC)

##### *Scientific Officer*

P Ralph, BAppSc (NSWIT), MAIBiol, PhD  
(UTS)

##### *Senior Technical Officer*

P Jones, TechCertBiol (STC), BAppSc (UTS)

### Centre for Materials Technology

##### *Director*

M A Wilson, PhD, DSc (Auck), CChem,  
FRACI

(Professor of Chemistry)

##### *Deputy Director*

J Unsworth, BSc (Wales), MSc (UMIST), PhD  
(Macq), CChem, CPhys, FAIP, FPRI  
(Emeritus Professor in Materials Science)

##### *Secretary*

G Lee, BSc (Hons) (UNSW), PhD (UNSW)  
(Research Scientist in Chemistry)

##### *Members*

A R Moon, BSc, PhD (Melb), FAIP  
(Dean of Science and Professor of Physics)

G B Smith, BSc (UNE), PhD (Monash), FAIP  
(Professor of Applied Physics)

A T Baker, BSc (Hons), PhD (UNSW),  
CChem, FRACI  
(Associate Professor of Chemistry)

A S Ray, BSc (Hons), MSc (Calc), PhD  
(UNSW), MIMMA  
(Senior Lecturer of Materials Science)

B Ben-Nissan, BSc (ITU), MSc, PhD (UNSW),  
MIMMA  
(Senior Lecturer of Materials Science)

J Schulte, MSc (Darmstadt), DSc (Oldenburg)  
(Lecturer in Applied Physics)

## Centre for Science Communication

### *Consultant*

P Pockley, BSc, DipEd (Melb), PhD (Oxf)

### *Administrator*

S Elliott, BSc (Hons), PhD (Macq)

## Institute for Coastal Resource Management

### *Associate Professor and Director*

K R Brown, BSc, PhD (UNSW), MAIBiol

### *Professor and Alternate Director*

R Robertson, MA (Vic), FRAIPR, FATRI,  
AITT

### *Professor*

S Vigneswaran, BSc (SLanka), MSc (AIT),  
DrIng (Montpellier), DSc  
(InstNatPolytechnique, Toulouse)

### *Adjunct Professor*

M D Burchett, BSc, PhD (Syd), DipEd (UNE),  
MAIBiol, FAIH

### *Associate Professors*

D Cheng, BSc (Hons), TTC, PhD (Tas),  
MASL, MAMSA, MFBA, MAIBiol  
C Hall, MEd (Syd), PhD (Macq)

### *Senior Lecturers*

D Booth, BSc (Hons) (Syd), MSc (Queens U),  
PhD (Oregon State)  
G C Callender, BBus (NSWIT), DipEd (Syd)  
Teach Coll), MComm (UNSW), CPA  
J E Dawkins, BSc (UWA), MTCP (Syd),  
MRAPI  
M Dawson, BPharm, PhD (Syd), CChem,  
MRACI, MPS  
E Frankel, BSc (Natal), PhD (Syd)  
R Lim, MSc (Mal), PhD (Waterloo) MAIBiol  
D A Morrison, BSc, PhD (Syd), MAIBiol  
S Wearing, Ord 4 Cert, BTP, MTP (UNSW)

### *Lecturers*

B J Bloomfield, ASTC, BSc (UNSW), MSc  
(Syd), PhD (Rutgers)  
R A Davies, BEc, LLB (Hons) (Syd), Solicitor  
of the Supreme Court of NSW  
A Griffin, BA (Geog), DipUrbStud (Macq),  
GradDipTourismM (KCAE)  
A Pulkownik, MSc (Syd)  
P Ralph, BAppSc (NSWIT), MAIBiol, PhD  
(UTS)  
S F Smith, BA, MHA (UNSW), LLM (Syd),  
Solicitor of the Supreme Court of NSW

### *Project Manager*

C Farmer, BSc

## National Centre for Groundwater Management

### **In conjunction with the Faculty of Engineering**

### *Professor of Groundwater Management and Centre Director*

M J Knight, BSc, PhD (Melb), FGS, MIE  
(Aust), MAIMM

### *Senior Lecturers*

W A Milne-Home, BSc (Leicester), MSc  
(Lond), PhD (Alta), CertEngGCH (UNSW)  
N P Merrick, MSc (Syd), GradDipDataProc  
(NSWIT)

### *Lecturer*

R G McLaughlan, BSc (Melb),  
GradDipCivEng, MAppSc, PhD (UNSW)

### *Office Manager*

P Xu

### *Administrative Assistant*

L Dixon

# Index

---

## A

Acupuncture Diagnosis  
of Musculoskeletal Disorders 158

Acupuncture Health Politics  
in Australia 156

Acupuncture Microsystems 159

Acupuncture Treatment  
of Musculoskeletal Disorders 159

Addresses and telephone numbers 6

Advanced Chinese Diagnosis 161

Advanced Electron Microscopy  
Techniques 129

Advanced Engineering Geology 118

Advanced Fossil Fuels 118

Advanced Geological Mapping 116

Advanced Materials  
and Characterisation 123

Advanced Mathematics and Physics 124

Advanced Petrology 115

Advanced Petrology (Honours) 117

Advanced Solid-state Physics 130

Advanced Structural Geology 116

Advanced Structural Geology (Honours) 117

Advanced X-ray Techniques 128

Advice from the NSW Department  
of Health 26

Alphabetical list of subjects 173

Analytical Biochemistry 139

Analytical Biochemistry Project 1 145

Analytical Biochemistry Project 2 145

Analytical Chemistry 1 (new) 105

Analytical Chemistry 1 (old) 106

Analytical Chemistry 2 (Advanced) 108

Analytical Chemistry 2 (new) 106

Analytical Chemistry 2 (old) 107

Analytical Chemistry 3 (new) 108

Analytical Techniques in Clinical  
Biochemistry 146

Anatomical Pathology 142

Animal Ecophysiology 143

Applied and Environmental  
Microbiology 143

Applied Clastic Basin Analysis  
(Honours) 119

Applied Mechanics 126

Applied Mechanics S 130

Applied Organic Chemistry 2 109

Applied Organic Chemistry 2  
(Advanced) 110

Applied Physics (Materials) 125

Applied Physics 1 125

Applied Physics 2 126

Applied Physics 3 128

Applied Thermodynamics 129

Applied Thermodynamics S 131

Applying for UTS courses 11

Approved External Subject 131

Aquatic Ecology 143

Australian Biota 138

Australian Soils 137

Austudy, eligibility for 27

## B

Bachelor of Applied Science in Geology 44

Bachelor of Health Science  
in Acupuncture 57

Bachelor of Health Science  
in Acupuncture (Honours) 58

Bachelor of Health Science in  
Acupuncture/Bachelor of Arts  
in International Studies 55

Bachelor of Health Science in Chinese  
Herbal Medicine 60

Bachelor of Health Science in Chinese  
Herbal Medicine (Honours) 61

Bachelor of Medical Science 61

Bachelor of Medical Science/  
Bachelor of Laws 79

Bachelor of Science (Honours) 62

Bachelor of Science (Honours)  
in Applied Chemistry 42

Bachelor of Science (Honours) in Applied  
Chemistry – Forensic Science 43

Bachelor of Science (Honours)  
in Applied Physics 55

Bachelor of Science (Honours)  
in Environmental Science 48

Bachelor of Science (Honours)  
in Geoscience 48

Bachelor of Science (Honours)  
in Materials Science 51

Bachelor of Science in Applied Chemistry 39

Bachelor of Science in Applied Physics 52

Bachelor of Science in Applied Physics/  
Bachelor of Engineering  
in Electrical Engineering/Diploma  
in Engineering Practice 56

Bachelor of Science in Biomedical Science 63

Bachelor of Science in Biotechnology 66

Bachelor of Science in Earth  
and Environmental Science 46

Bachelor of Science in Environmental  
and Urban Horticulture 72

Bachelor of Science in Environmental  
Biology 70

Bachelor of Science in Materials Science 49

Bachelor of Science in Science Education 75

Bachelor of Science/Bachelor of Arts  
in International Studies 80

Bachelor of Science/Bachelor of Laws 76

Basin Analysis 114

Behavioural Sciences 151

- Biochemical Pathophysiology 145  
 Biochemistry 1 138  
 Biochemistry 2 139  
 Biocomputing 145  
 Biological Evidence 134  
 Biological Hazards and Toxicology 132  
 Biology 1 138  
 Biology 2 138  
 Biology and Ecology 134  
 Biomedical Science Upgrade 150  
 Biomedical Sciences 1 145  
 Biomedical Sciences 2 145  
 Biomonitoring 138  
 Bioprocessing 143  
 Biosystems 149  
 Biotic Resources 153  
 Boards 178
- C**
- Campus maps 7  
 Case Studies in Clinical Biochemistry 146  
 Centres and Institutes 18
  - Centre for Biomedical Technology 18
  - Centre for Ecotoxicology 18
  - Centre for Materials Technology 19
  - Centre for Science Communication 19
  - Cooperative Research Centre
    - for Aquaculture 19
    - for Cardiac Technology 19
    - for Renewable Energy 19
  - Institute for Coastal Resource Management 20
  - National Centre for Groundwater Management 21
- Chemical Process Control 107  
 Chemical Safety 107  
 Chemical Safety (OHS) 132  
 Chemical Safety and Legislation 106  
 Chemical Thermodynamics 106  
 Chemistry 1A 104  
 Chemistry 1C 104  
 Chemistry 2A 104  
 Chemistry 2C 105  
 Chemistry and Materials Science 103  
 Chemistry and Pharmacology
  - of Illicit Drugs 110
- Chemistry Learning Resources Centre 26  
 Chinese Diagnostic System 161  
 Chinese Herbal Formulae 161  
 Chinese Herbal Medicine 1 162  
 Chinese Herbal Medicine 2 162  
 Chinese Herbal Practice 1 163  
 Chinese Herbal Practice 2 164  
 Chinese Massage (*Tuina*) 162  
 Chinese Medical Approach to Health and Disease, The 158  
 Chinese Model of *Qi* and its Pathways, The 158
- Classical Herbalism 165  
 Clinic – Level 2 (A&M) 160  
 Clinic – Level 2 (CHM) 160  
 Clinic – Level 3 (A&M) 161  
 Clinic – Level 3 (CHM) 161  
 Clinic – Level 4 (A&M) and Point Location 2 161  
 Clinic – Level 4 (CHM) and Chinese Herbal Practice 161  
 Clinic – Level 5 (A&M) and Advanced Treatment Techniques 162  
 Clinic – Level 5 (CHM) and Chinese Herbal Practice 162  
 Clinic dress 24  
 Clinical Acupuncture 155  
 Clinical Bacteriology 141  
 Clinical Biochemistry – Advanced Aspects 147  
 Clinical Biochemistry 1 141  
 Clinical Biochemistry 2 141  
 Clinical Chinese Herbalism 162  
 Clinical Features of Disease 162  
 Clinical Internship (A&M) 157  
 Clinical Internship (CHM) 163  
 Clinical Laboratory Management 146  
 Clinical Practice 1 158  
 Clinical Practice 2 159  
 Clinical Theory and Clinic – Level 1 (A&M) 159  
 Clinical Theory and Clinic – Level 1 (CHM) 159  
 Clinical Theory and Clinic – Level 6 (A&M) 163  
 Clinical Theory and Clinic – Level 6 (CHM) 163  
 Clinical training, external 26  
 Coastal Ecosystems 153  
 Coastal Planning 153  
 Coastal Processes 154  
 Coastal Resource Policy 154  
 Coastal Zone Law 148  
 Code of Conduct for students of the UTS College of Traditional Chinese Medicine 24  
 College of Traditional Chinese Medicine 17  
 College of Traditional Chinese Medicine Policies 25  
 Committees 178  
 Community and Population Ecology 137  
 Complex Forensic Cases (Chemistry) 110  
 Complex Forensic Cases (Law) 171  
 Composites (new) 123  
 Composites (old) 122  
 Computational Mathematics and Physics 170  
 Computational Physics 126  
 Computer Modelling of Physical Systems 128  
 Computing and Mathematics for Science 169

- Computing for Groundwater Specialists 103  
 Computing for Science 168  
 Confidentiality 25  
 Contaminated Site Management 113  
 Contemporary China 172  
 Convergent Margin Tectonics (Honours) 118  
 Cooperative Research Centre  
   for Aquaculture 19  
 Cooperative Research Centre for Cardiac  
   Technology 20  
 Cooperative Research Centre  
   for Renewable Energy 20  
 Coordination and Organometallic  
   Chemistry 110  
 Coordination and Organometallic  
   Chemistry (Advanced) 110  
 Corrosion and Degradation of Materials 122  
 Corrosion Science 110  
 Course Advisory Committees 179  
 Courses and codes, list of 33  
 Courses  
   Postgraduate 85  
     Graduate Certificate 85  
     Graduate Diploma 90  
     Master's degrees (by coursework) 91  
     Postgraduate degrees  
       by research/thesis 101  
   Undergraduate 36  
     Honours degree 38  
     Pass degree 36  
 Crustal and Mantle Processes 116  
 Current Topics in Clinical Microbiology 148  
 Current Urban and Environmental  
   Issues A 136  
 Current Urban and Environmental  
   Issues B 136  
 Current Urban and Environmental  
   Issues C 136  
 Cytopathology 144
- D**
- Data Analysis in Occupational Health  
   and Safety 132  
 Dean's Message 14  
 Design and Selection of Materials 122  
 Device Physics 130  
 Diagnostic Bacteriology 146  
 Discrimination 25  
 Disease States 162
- E**
- Earth Materials 114  
 Earth Resources 115  
 Earth Science 1 113  
 Earth Systems and the Environment 113  
 Ecological Modelling 139  
 Ecological Sampling 140  
 Economic Geology 114  
 Economics of Coastal Resources 148  
 Ecosystem Assessment 149  
 Ecotoxicology Project (F/T) 149  
 Ecotoxicology Project (P/T) 149  
 Electrochemistry 106  
 Electromagnetics and Optics 129  
 Electronics 125  
 Electronics 2 126  
 Electronics 2 S 130  
 Electronics and Interfacing 128  
 Engineering and Environmental  
   Geology 115  
 Engineering Geology 118  
 Engineering Mathematics 2A 169  
 Environment, Health and Safety 21  
 Environmental and Quaternary Geology 118  
 Environmental Assessment  
   and Planning 102  
 Environmental Chemistry 108  
 Environmental Chemistry (Advanced) 109  
 Environmental Engineering and  
   Management Practices 102  
 Environmental Management Procedures 139  
 Environmental Measurement 144  
 Environmental Microbiology 140  
 Environmental Microbiology  
   for Engineers 150  
 Environmental Risk Assessment  
   and Management 149  
 Environmental Toxicology 139  
 Epidemiology and Disease Control 148  
 Eukaryotic Microbiology 142  
 Evaluating Occupational Health and Safety  
   (Construction Industry) 133  
 Experimental Design and Methods 146  
 Experimental Design in Ecology 137  
 Exploration and Mining Geology 117  
 Exploration Geochemistry 116  
 Exploration Geophysics 115  
 Extractive Metallurgy 104
- F**
- Faculty Board in Science 178  
 Faculty information 14  
 Faculty Mission Statement 14  
 Faculty of Science 15  
 Faculty of Science Environmental,  
   Health and Safety Action Plan 22  
 Field Methods in Ecotoxicology 148  
 Field Project 118  
 Field Studies 1 113  
 Field Studies: Marine Sciences 144  
 Field Studies: Mountain Ecology 143  
 Field Studies: Semiarid Ecology 143  
 Field Theory 127  
 Fire and Explosion Investigation 110  
 Fire Investigation 111  
 First Aid Certificate Course 156  
 Fold Belts and Cratons 114  
 Forensic Examination of Physical  
   Evidence 2 109  
 Forensic Examination of Physical  
   Evidence 3 111

Forensic Imaging 106  
 Forensic Research Project 111  
 Forensic Toxicology 1 (new) 108  
 Forensic Toxicology 1 (old) 108  
 Forensic Toxicology 2 (new) 109  
 Forensic Toxicology 2 (old) 109  
 Fossil Fuels 116  
 Fossil Fuels (Honours) 117  
 Foundations of Helping and Caring 171  
 Foundations of TCM 155

**G**

General University information 5  
 Geochemistry 114  
 Geological Resources 154  
 Geophysics 116  
 Geophysics and Remote Sensing  
 of Groundwater Resources 112  
 Geopollution Management 112  
 GIS and Resources Assessment 153  
 Graduate Certificate courses 85  
 Graduate Certificate in Biochemical  
 Analysis 86  
 Graduate Certificate in Clinical  
 Biochemistry 86  
 Graduate Certificate in Diagnostic  
 Bacteriology 89  
 Graduate Certificate in Environmental  
 Engineering and Management 88  
 Graduate Certificate in Field Methods  
 in Ecotoxicology 87  
 Graduate Certificate in Laboratory Methods  
 in Ecotoxicology 87  
 Graduate Certificate in Management  
 in Ecotoxicology 87  
 Graduate Certificate in Medical  
 Biochemistry 86  
 Graduate Certificate in Medical  
 Microbiology 95  
 Graduate Certificate in Molecular  
 Microbiology 89  
 Graduate Certificate in Occupational  
 Health and Safety 89  
 Graduate Certificate in Occupational  
 Health and Safety Management 89  
 Graduate Certificate in Parasitology  
 and Mycology 89  
 Graduate Certificate in Principles  
 of Ecotoxicology 87  
 Graduate Certificates in Coastal Resource  
 Management 86  
 Graduate Clinic Internship (CHM) 164  
 Graduate Clinic Level 1 (CHM) 164  
 Graduate Clinic Level 2 (CHM) 165  
 Graduate Clinic Level 3 (TCM) 164  
 Graduate Diploma course 90  
 Graduate Diploma in Hydrogeology  
 and Groundwater Management 91  
 Groundwater Computing 103  
 Groundwater Engineering Projects  
 (GD) F/T, P/T 102

Groundwater Engineering Projects  
 (M) F/T, P/T 102  
 Groundwater Geology 113  
 Groundwater Geophysics 112  
 Groundwater Modelling 103  
 Groundwater Science Projects  
 (GD) F/T, P/T 113  
 Groundwater Science Projects  
 (M) F/T, P/T 112

**H**

Haematology 1 142  
 Haematology 2 142  
 Health and Welfare, Student 26  
 Health Sciences 1 159  
 Health Sciences 2 160  
 Hepatitis B inoculation 26  
 Herbal Prescriptions 165  
 History and Philosophy of TCM 155  
 Honours (Biological and Biomedical  
 Sciences) 137  
 Honours (Biological and Biomedical  
 Sciences) (2yrs) 137  
 Honours (Chemistry) 111  
 Honours (Environmental Science) 119  
 Honours (Geoscience) 119  
 Honours (Materials Science) 123  
 Honours (Physics) 131  
 Honours degree courses 38  
 Honours Project 123, 163  
 Honours Project Proposal 123  
 Honours Research Project 112  
 Honours Seminar 111  
 Horticultural Financial Management 134  
 Horticultural Production Management 134  
 Horticulture 1 135  
 Horticulture 2 135  
 Hospital Training in China 155  
 Human Factors/Ergonomic Design 132  
 Human Parasitology and Mycology 146  
 Hydrogeochemistry 112  
 Hydrogeology 112

**I**

Immunobiology Unit 17  
 Immunological Responses to Infection 146  
 Immunology 1 142  
 Immunology 2 142  
 In-country Study 1: China 172  
 In-country Study 2: China 172  
 Independent Research Project  
 (Postgraduate) 156  
 Individual Project – Life Sciences 145  
 Individual Project P/G – Life Sciences 149  
 Individual Research Project P/G –  
 Clinical Biochemistry F/T 147  
 Individual Research Project –  
 Clinical Biochemistry P/T 147  
 Industrial Ceramics 121  
 Industrial Metallurgy 121



Industrial Training (Applied Chemistry Honours) 112  
 Industrial Training (Applied Chemistry) P/T 112  
 Industrial Training (Applied Geology) P/T 120  
 Industrial Training (Honours) 119  
 Industrial Training (Materials Science) P/T 124  
 Industrial Training 1 (Applied Chemistry) 112  
 Industrial Training 1 (Applied Geology) 120  
 Industrial Training 1 (Applied Physics Honours) 131  
 Industrial Training 1 (Materials Science) 124  
 Industrial Training 1 (Physics) 131  
 Industrial Training 2 (Applied Chemistry) 112  
 Industrial Training 2 (Applied Geology) 120  
 Industrial Training 2 (Materials Science) 124  
 Industrial Training 2 (Physics) 131  
 Industrial Waste Minimisation 102  
 Information  
   Centres 11  
   Faculty 14  
   General University 5  
   Students 21  
 Inorganic Chemistry 105  
 Inorganic Chemistry 1 (Transition Metal Chemistry) 107  
 Inorganic Chemistry 2 (New Inorganic Materials) 107  
 Institute for Coastal Resource Management 20  
 Instrumentation for Materials Scientists 121  
 International Studies electives 35  
 International Studies subjects 171  
 Introduction to Biological Fluids 144  
 Introduction to Botany 160  
 Introduction to Chinese Herbal Medicine 160  
 Introduction to Ecotoxicology 147  
 Introduction to Materials 120  
 Introduction to Tai Qi Chuan, An 156  
 Introduction to TCM 159  
 Introduction to Traditional Acupuncture Theory 157  
 Introductory Marine Ecology 140

**L**

Laboratory Methods in Ecotoxicology 147  
 Landscape Design 135  
 Learning Centres 26  
   Chemistry Resources 26  
   Physics 26  
 Learning in Science 1 167  
 Learning in Science 2 168  
 Legal Aspects of Occupational Health and Safety 133

**M**

Majors, Second 82  
 Mantoux testing 26  
 Mapping and Remote Sensing 115, 139  
 Master of Coastal Resource Management 93  
 Master of Health Science in Traditional Chinese Medicine 94  
 Master of Occupational Health and Safety 95  
 Master of Science (Honours) in Clinical Biochemistry 96  
 Master of Science (Honours) in Ecotoxicology 98  
 Master of Science (Honours) in Medical Microbiology 100  
 Master of Science in Clinical Biochemistry 95  
 Master of Science in Ecotoxicology 97  
 Master of Science in Hydrogeology and Groundwater Management 98  
 Master of Science in Medical Microbiology 99  
 Master's degrees (by coursework) 92  
 Master's Project - Traditional Chinese Medicine 64  
 Master's Thesis (Applied Chemistry) F/T 112  
 Master's Thesis (Applied Chemistry) P/T 112  
 Master's Thesis (Applied Geology) F/T 119  
 Master's Thesis (Applied Geology) P/T 119  
 Master's Thesis (Applied Physics) F/T 131  
 Master's Thesis (Applied Physics) P/T 131  
 Master's Thesis (Biol and Biomed) F/T 152  
 Master's Thesis (Biol and Biomed) P/T 152  
 Master's Thesis (Materials Science) F/T 124  
 Master's Thesis (Materials Science) P/T 124  
 Materials Engineering 1 120  
 Materials Engineering 2 120  
 Materials Physics 127  
 Materials Physics S 130  
 Materials Technology 120  
 Mathematical Modelling 1 168  
 Mathematical Modelling 2 169  
 Mathematical Modelling for Science 169  
 Mathematics 1 (Life Sciences) 168  
 Mathematics and Scientific Software 170  
 Mechanical Properties of Materials 120  
 Medical Devices and Diagnostics 151  
 Medical Science 1 150  
 Medical Science 2 150  
 Meeting Special Needs in the Secondary School 167  
 Message from the Dean 14  
 Metallurgical Chemistry 109  
 Metallurgical Chemistry (Advanced) 110  
 Microbiology 1 138  
 Microbiology 2 140  
 Microbiology 3 140  
 Microprocessors in Instrumentation 127

- Microprocessors in Instrumentation S 130  
 Microsystems 161  
 Mineral Deposits 118  
 Mineral Science Project 118  
 Mineralogy and Petrology 113  
 Modern Standard Chinese Language  
 and Culture 171  
 Modernisation and Social Change 170  
 Molecular Biology 1 140  
 Molecular Biology 2 141  
 Molecular Genetics Unit 17  
 Molecular Microbiology 148  
 Molecular Parasitology Unit 17
- N**
- Narcotics and Drugs of Abuse 111  
 National Centre for Groundwater  
 Management 21  
 Neuroscience 151  
 NSW Department of Health, advice 26  
 Nuclear Physics 127  
 Nuclear Physics S 130  
 Nutrition in a Traditional Chinese  
 Medical Context 156
- O**
- Occupational Hazard Analysis 132  
 Occupational Health and Safety  
 in Society 131  
 Occupational Health and Safety  
 Management 133  
 Occupational Health and Safety Project 133  
 Occupational Health Services 132  
 Open Space Management 134  
 Organic Chemistry 1 105  
 Organic Chemistry 2 (old) 106  
 Organic Chemistry 2 (Structure Elucidation  
 and Synthesis) 107  
 Organisational Behaviour  
 and Communication 132
- P**
- Pass degree courses 36  
 Pathophysiology 1 166  
 Pathophysiology 1 (TCM) 157  
 Pathophysiology 2 166  
 Pathophysiology 2 (TCM) 157  
 Patient information, recording 25  
 Patient records 25  
 People and the Physical Environment 132  
 Pharmacognosy 162  
 Pharmacology 1 151  
 Pharmacology 2 152  
 PhD Thesis (Biol and Biomed) F/T 152  
 PhD Thesis (Biol and Biomed) P/T 152  
 Philosophy, Religion and Culture 156  
 Physical Chemistry 1 105  
 Physical Chemistry 2 108  
 Physical Evidence 1 107  
 Physical Evidence 2 108  
 Physical Mathematics 170  
 Physical Metallurgy 121  
 Physical Modelling 124  
 Physical Optics 129  
 Physical Properties of Materials 121  
 Physics 1A 125  
 Physics 1C 125  
 Physics 1S 130  
 Physics 2 125  
 Physics 2 S 130  
 Physics 3 125  
 Physics 4 126  
 Physics for Electronics S 130  
 Physics Learning Centre 26  
 Physiological Foundations of Health 1 165  
 Physiological Foundations of Health 2 165  
 Physiological Systems 151  
 Physiology of Qi, The 160  
 Plant Genetics and Breeding 136  
 Plant Pathology 136  
 Plant Physiology 136  
 Plant Production and Growth Media 135  
 Plant Tissue Culture 135  
 Plants in the Landscape 134  
 Point Location 157  
 Point Location 1 (and Treatment  
 Techniques) 160  
 Pollution Assessment 154  
 Polymer Science 121  
 Polymer Technology 121  
 Postgraduate courses 85  
 Postgraduate degrees by research/thesis 101  
 Practice Management 163  
 Practicums 25  
 Principal dates for 1998 12  
 Principles and Practice of Biotechnology 139  
 Principles of Botany 164  
 Principles of Chinese Herbal Medicine 164  
 Principles of Clinical Biochemistry 145  
 Principles of Forensic Science 105  
 Principles of Instrumentation 129  
 Principles of Instrumentation S 131  
 Principles of Pharmacognosy 164  
 Prizes 27  
 Professional Experience  
 (Biol/Biom) F/T 152  
 Professional Experience  
 (Biol/Biom) P/T 153  
 Professional Writing and  
 Communication 171  
 Project (Honours) 119, 131  
 Project 1 (Chemistry) 111  
 Project 2 (Chemistry) 111  
 Project A 127  
 Project B 129  
 Project Seminar 116  
 Project Workshops 155  
 Psycho-Oncology Unit 17  
 Psychology of Secondary Students 167  
 Psychophysiology 152  
 Public Administration and Management 153

**Q**

- Qi Gong: Its Use in Acupuncture* 157
- Quantum and Solid State Physics 127
- Quantum Physics 1 126
- Quantum Physics 1 S 130
- Quantum Physics 2 129
- Quantum Physics 2 S 131

**R**

- Reaction Kinetics 108
- Remarking of assessment items 24
- Remote Sensing 117
- Research Developments in Geoscience 119
- Research Methodology – Medical
  - Microbiology 148
- Research Methods 1 150
- Research Methods 2 150
- Research Project – Medical
  - Microbiology F/T 149
- Research Project – Medical
  - Microbiology P/T 149
- Research Proposal (Occupational Health and Safety) 133
- Research Workshops 1 158
- Research Workshops 2 158
- Resource Management 114
- Risk Assessment and Management 154
- Risk Management 133

**S**

- Scholarships 27
- Science Mathematics 2 168
- Science Mathematics 3 168
- Second majors 82
- Secondary Practicum 1 167
- Secondary Practicum 2 167
- Sedimentary Geology 114
- Services, refusal of 25
- Social Bases of Education 167
- Social Crisis 156
- Solid-state Physics 127
- Solid-state Physics S 130
- Special Points and Systems 155
- Special Reading Assignment –
  - Life Sciences 145
- Special Reading Assignment P/G –
  - Life Sciences 149
- Special Topics in TCM (Intermodal and Professional) 163
- Spectroscopy and Structure 105
- Staff list 184
- Statistical Design and Analysis 168
- Statistics in Bioscience 148
- Structural Geology 114
- Student
  - Health and Welfare 25
  - Information 21
  - Support Centres in the
    - Faculty of Science 26

**Subjects**

- Alphabetical list of 173
- Descriptions 102
- International Studies 171
- Offered by other faculties 167
- Offered for Faculty of Nursing
  - students 165
- Subtle Dimensions of Healing, The 156
- Surface Chemistry 108
- Surface Hydrology and Groundwater 103
- Surface Properties of Materials 122
- Surficial Processes and Products 115
- Systems View of Life, A 156

**T**

- Technical Ceramics 122
- Technical Communication 103
- Techniques of Materials Analysis 128
- Technology and Innovation Forum 128
- Technology, Society and Change 153
- Tectonics 117
- Tectonics and Surface Dynamics 116
- Terrestrial Ecosystems 137
- Therapeutic Techniques and *Tuina* (Chinese Massage) 158
- Thermodynamics 104
- Thermodynamics and Energy 126
- Thermodynamics and Energy S 130
- Topics in Coastal Management 154
- Tourism, Recreation and Protected Area Management 155
- Toxic Materials in the Environment 141
- Transducers and Devices 129
- Transfusion Science 141
- Treatment of Scientific Data 104

**U**

- Undergraduate courses 36
- Undergraduate Research Project 136
- Units within the Faculty 17
  - College of Traditional Chinese
    - Medicine 17
  - Immunobiology 17
  - Molecular Genetics 17
  - Molecular Parasitology 17
  - Psycho-Oncology 17
- University information, General 5
- Urban Stormwater Management 154
- Uses of Australian Plants 135
- UTS Information Centres 11

**V**

- Vacuum and Thin Film Physics 126

**W**

- Water Quality Management 103
- Written and Oral Reporting 170

The background of the page features a large, faint watermark of the University of Technology, Sydney logo. The logo is a stylized, geometric representation of a person or a figure, composed of various shapes like diamonds and rectangles, all in shades of orange and yellow. It is centered on the page and serves as a background for the text.

**University of Technology, Sydney**

PO Box 123

Broadway NSW 2007

Australia

Telephone (02) 9514 2000

**Course inquiries within Australia**

Information Service (02) 9514 1222

email [info.office@uts.edu.au](mailto:info.office@uts.edu.au)

**International inquiries**

International Programs +61 2 9514 1531

email [intlprograms@uts.edu.au](mailto:intlprograms@uts.edu.au)

**World Wide Web** <http://www.uts.edu.au>

**ISSN 1329-0320**

Price \$