



Faculty of

# Mathematical and Computing Sciences

Handbook



University of Technology, Sydney

---

# 1998

***UTS Faculty of  
Mathematical and  
Computing Sciences  
Handbook  
1998***

The University attempts to ensure that the information contained in this handbook is correct as at 28 November 1997. The University reserves the right to vary any matter described in the handbook at any time without notice.



University of Technology, Sydney

**Equal opportunity**

It is the policy of the University of Technology, Sydney to provide equal opportunity for all persons regardless of sex, race, marital status, family responsibilities, disability, sexual preference, age, political conviction or religious belief.

**Free speech**

The University supports the right to freedom of speech and the rights of its members to contribute to the diversity of views presented in our society.

**Non-discriminatory language**

UTS has adopted the use of non-discriminatory language as a key strategy in providing equal opportunity for all staff and students. Guidelines for the use of non-discriminatory language have been developed and all members of the University community are encouraged to use them.

**Editorial and production:**

Publications Branch,  
Registrar's Division

**Cover**

*UTS – The Global Classroom*  
*UTS congratulates our first group of International Studies students who will spend 1998 studying overseas in the country of their choice.*

External Relations Unit

# Table of contents

---

<b>General University information</b>	<b>5</b>
Preface	5
Addresses and telephone numbers	6
Campus maps	7
Applying for UTS courses	11
UTS Information Centres	11
Principal dates for 1998	12
<b>Faculty information</b>	<b>14</b>
Message from the Dean	14
Faculty Mission Statement	15
Information for students	16
Faculty Office contacts	17
List of courses and codes	23
<b>School of Mathematical Sciences</b>	<b>24</b>
Prizes	27
School contacts	28
Undergraduate courses	30
Bachelor of Science in Mathematics	30
Bachelor of Science (Honours) in Mathematics	35
Bachelor of Science in Mathematics/ Bachelor of Arts in International Studies	36
Bachelor of Mathematics and Finance	39
Bachelor of Mathematics and Finance (Honours)	41
Bachelor of Mathematics and Finance/ Bachelor of Arts in International Studies	42
Postgraduate courses	45
<i>Postgraduate research degrees</i>	45
Doctor of Philosophy	46
Master of Science	46
<i>Postgraduate coursework programs</i>	47
Master of Science in Operations Research	47
Graduate Diploma in Applicable Mathematics	48
Graduate Diploma in Mathematics and Finance	48
Graduate Diploma in Operations Research	49
Graduate Diploma in Statistics	50
Graduate Certificate in Mathematical Sciences	51
Subject descriptions	53
Subjects offered by other faculties	63
International Studies subjects	66
Numerical list of subjects	78
Alphabetical list of subjects	81



<b>School of Computing Sciences</b>	<b>83</b>
Academic advisers for 1998	83
Prizes and scholarships	85
School contacts	86
Undergraduate courses	87
Bachelor of Science in Computing Science	87
Bachelor of Information Technology	98
Bachelor of Science in Computing Science/ Bachelor of Arts in International Studies	101
Bachelor of Science in Computing Science/Bachelor of Laws	104
Double degree in Business and Computing Science	105
Bachelor of Science (Honours) in Computing Science	105
Bachelor of Computing	107
Bachelor of Computing/Bachelor of Arts in International Studies	108
Postgraduate courses	109
<i>Postgraduate research degrees</i>	109
Doctor of Philosophy	110
Master of Science	111
<i>Postgraduate coursework programs</i>	113
Master of Science in Computing	113
Master of Business in Information Technology Management	118
Graduate Diploma in Information Technology Management	118
Graduate Certificate in Information Technology Management	118
Master of Interactive Multimedia	122
Graduate Diploma in Interactive Multimedia	122
Graduate Certificate in Interactive Multimedia	122
Master of Science in Internetworking	124
Graduate Diploma in Internetworking	124
Graduate Certificate in Internetworking	124
Graduate Diploma in Information Technology	125
Graduate Certificate in Human–Computer Interaction	127
Graduate Certificate in Information Technology	128
Subject descriptions	129
Subjects offered by other faculties	146
Numerical list of subjects	154
Alphabetical list of subjects	162
<b>Boards and committees</b>	<b>165</b>
Faculty Board in Mathematical and Computing Sciences	165
Faculty Graduate Studies Committee	165
School Advisory Committees	166
Course Advisory Committees	166
<b>Staff list</b>	<b>168</b>
<b>Index</b>	<b>171</b>

# **General University information**

---

## **PREFACE**

Welcome to the University of Technology, Sydney (UTS), the fourth largest university in New South Wales. UTS has a reputation for delivering quality higher education that meets the needs of the professions, the technologies and the community. It is a multicampus university operating at three major locations in the Sydney metropolitan area – Broadway, Kuring-gai and St Leonards – and offering over 80 undergraduate and 200 postgraduate courses to nearly 22,000 students.

The main work of course development and delivery at UTS is carried out by the Faculties of Business; Design, Architecture and Building; Education; Engineering; Humanities and Social Sciences; Law; Mathematical and Computing Sciences; Nursing; and Science; and the Institute for International Studies. Each of these is responsible for a range of programs across a number of key disciplines.

Every year UTS produces 10 faculty/institute handbooks containing information about all the courses and subjects offered at UTS, and including details of course content, attendance patterns, credit point requirements and combined degrees, plus important faculty and student information.

These handbooks are part of a suite of publications which includes the *UTS Calendar* and the postgraduate and undergraduate student handbooks. The *UTS Calendar* contains the University Act, By-law and Rules, a list of courses offered at the University, and other useful University information. Copies are held in the University's libraries and faculty offices, and may be purchased at the Co-op Bookshop. The student handbooks contain general information about application procedures, academic progression, assistance schemes, and services and facilities offered to students. You will be given a free copy of one of these when you enrol.

If you need more information about the University or its courses, you can contact the UTS Information Service or your faculty office. The University provides a whole range of services for students, and there are plenty of qualified people here to give you help and advice.

We hope you enjoy your time as a student at UTS, and wish you well in your studies.

## ADDRESSES AND TELEPHONE NUMBERS

### University of Technology, Sydney

#### Postal address

PO Box 123  
Broadway  
NSW 2007 Australia

#### Telephone

(02) 9514 2000  
International: +61 2 9514 2000  
Fax: (02) 9514 1551

#### World Wide Web

<http://www.uts.edu.au>

### City campus

#### Broadway

- Building 1 (Tower Building)  
1 Broadway, Ultimo
- Building 2  
1 Broadway, Ultimo
- Building 3 (Bon Marche Building)  
Cnr Harris St and Broadway, Ultimo
- Building 4  
Cnr Thomas and Harris Streets, Ultimo
- Building 6  
702–730 Harris St, Ultimo
- Broadway Terraces  
9, 11 and 13 Broadway, Ultimo
- Magic Pudding Childcare Centre  
Thomas St, Ultimo

#### Haymarket

- Building 5  
Cnr Quay St and Ultimo Rd, Ultimo

#### Blackfriars

- Cnr Blackfriars and Buckland Steets,  
Chippendale
- Blackfriars Childrens Centre  
Buckland St, Chippendale

#### Smail Street

- 3 Smail St, Ultimo

#### Wembley House

- 839–847 George St, Sydney

#### Harris Street

- 645 Harris St, Ultimo

#### Student housing

- Bulga Ngurra  
23–27 Mountain St, Ultimo
- Geegal  
82–84 Ivy St, Ultimo

#### Australian Technology Park Sydney Ltd

#### Institute for Sustainable Futures

- Suite 213  
National Innovation Centre  
Cnr Garden, Cornwallis and Boundary  
Streets  
Eveleigh NSW 1430  
Telephone: (02) 9209 4350  
Fax: (02) 9209 4351

#### Kuring-gai campus

- Eton Rd, Lindfield  
(PO Box 222, Lindfield NSW 2070)

#### St Leonards campus

- Dunbar Building  
Cnr Pacific Highway and  
Westbourne St, Gore Hill
- Clinical Studies Building, Centenary  
Lecture Theatre and West Wing  
Reserve Rd, Royal North Shore Hospital
- Gore Hill Research Laboratories  
Royal North Shore Hospital

#### Yarrowood conference and research centre

- 689 Springwood Rd  
Yarramundi NSW 2753

#### Stroud Field Station

- 2605 The Bucketts Way  
Booral NSW 2425

# CAMPUS MAPS

## City campus

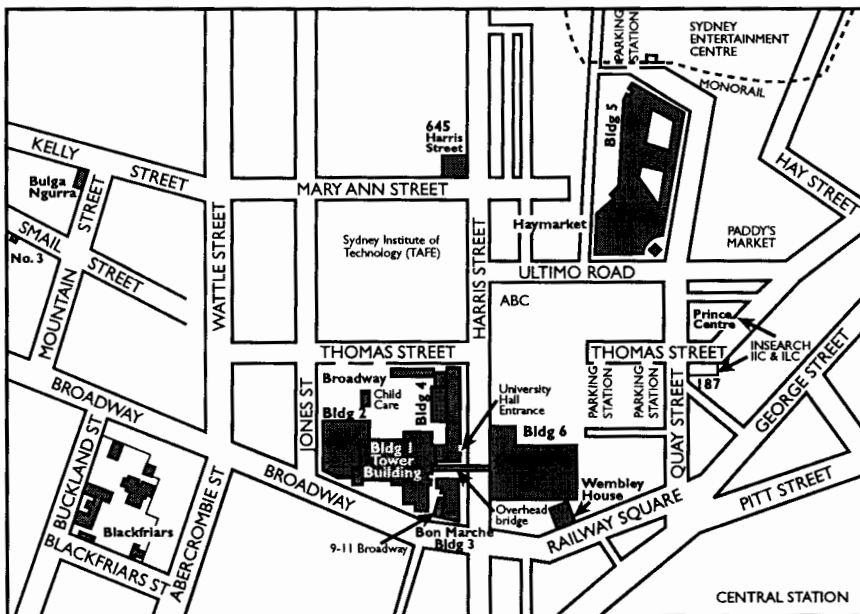

## Broadway

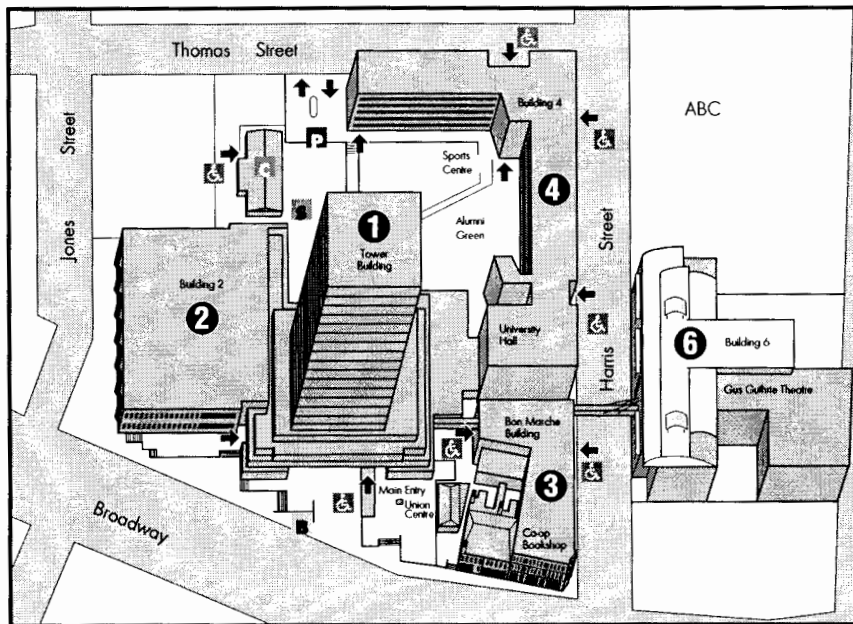

Haymarket

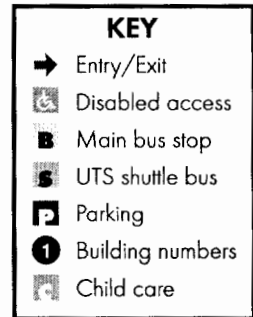
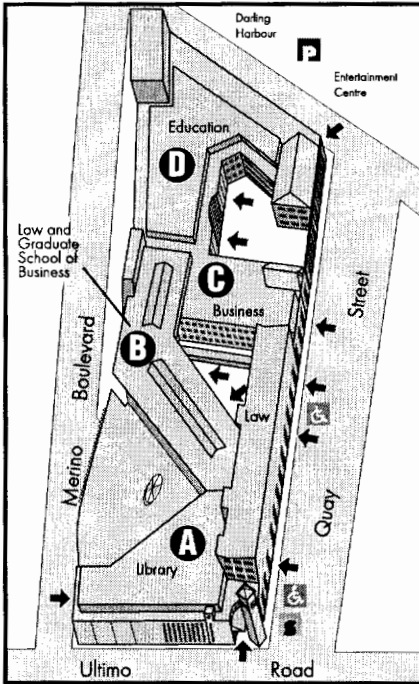

Blackfriars

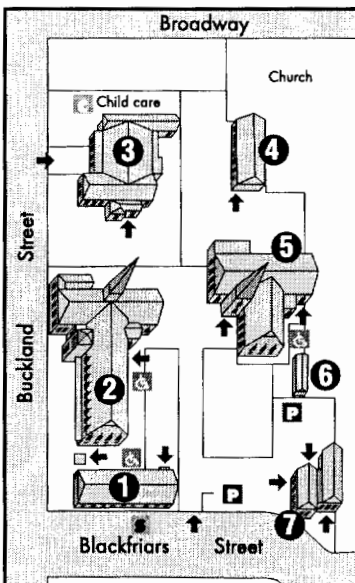

### Kuring-gai campus

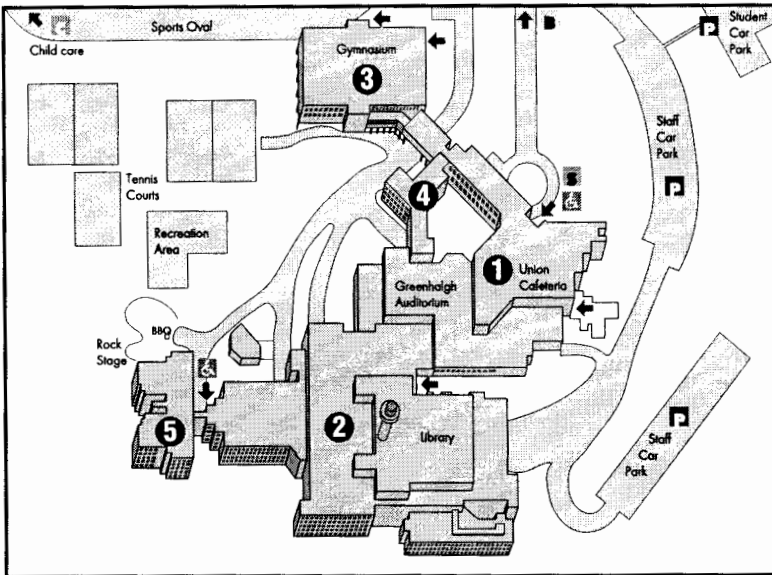
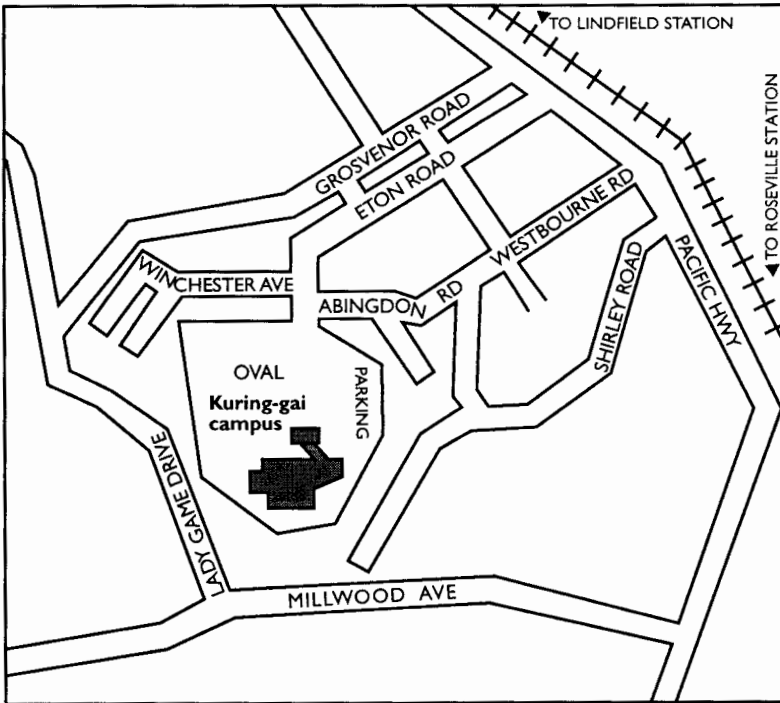

### St Leonards campus

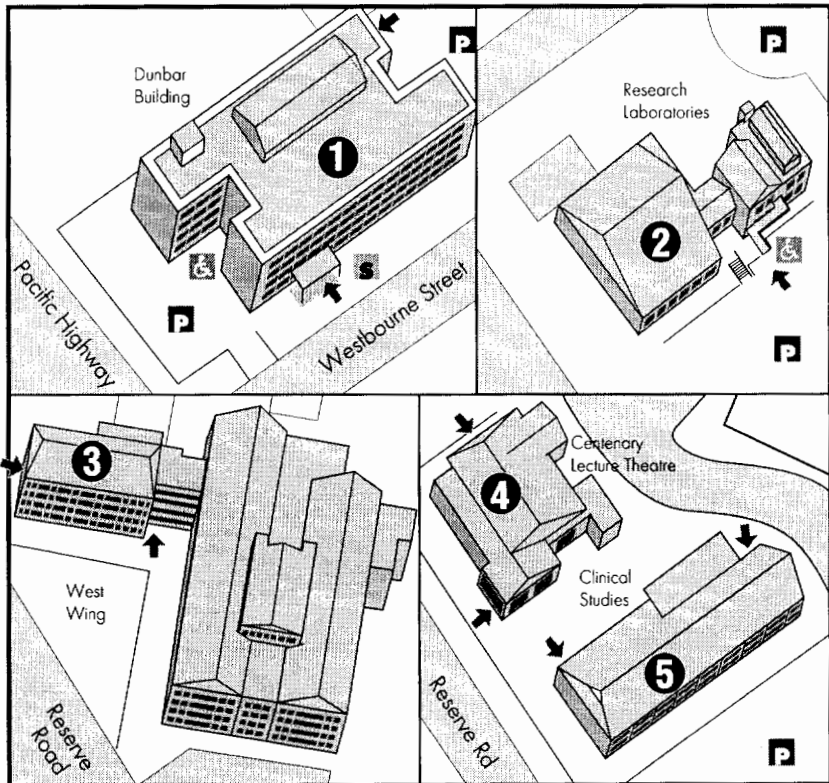
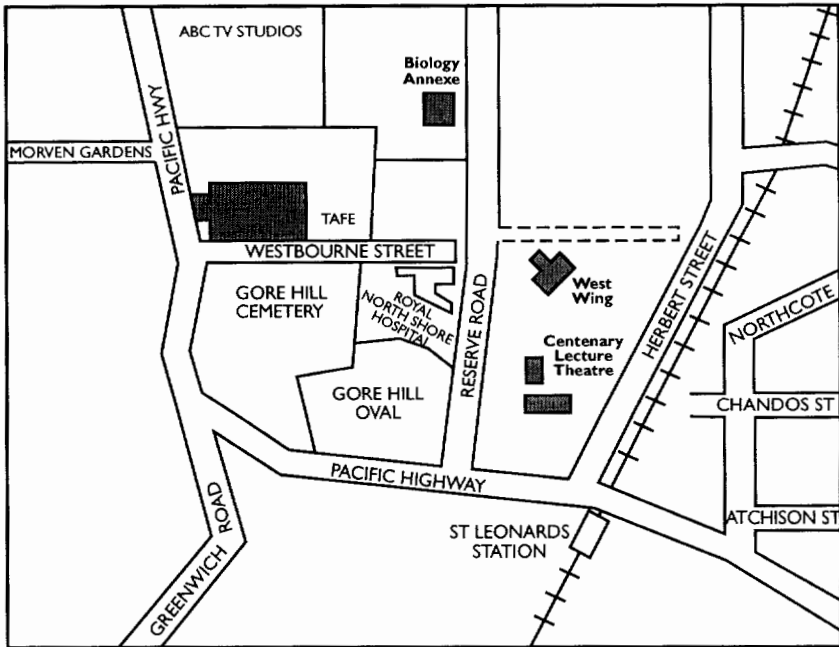



## APPLYING FOR UTS COURSES

### Undergraduate

Applications for the majority of those undergraduate courses which start at the beginning of each year must be lodged through the NSW and ACT Universities Admissions Centre (UAC) between August and October. Please check the application requirements in the *UAC Guide*, as some of these courses close for applications at the end of September. Some courses are also available by direct application to UTS. These are usually courses that are not available to school leavers.

A small number of UTS courses also start in the middle of the year. Applications for these should be made direct to UTS in May.

Contact the UTS Information Centres for more information.

### Postgraduate

Applications for postgraduate courses should be made direct to UTS. For courses starting at the beginning of the year, most applications are open from August to October, but some may have earlier closing dates. For courses

starting in the middle of the year, applications close in May.

Contact the UTS Information Centres for more information.

### Non-award and External Award study

Non-award and External Award study allows individuals and students from other universities to study single subjects at UTS. There are four application periods, and closing dates are different for each of the semesters. Some faculties may have special application procedures which will vary depending on the subjects chosen.

Contact the UTS Information Centres for more information.

### International students

International students need to satisfy the normal UTS entry requirements and be proficient in English. For details on courses, fees and application procedures, contact International Programs.

## UTS INFORMATION CENTRES

Street address	Postal address	Telephone/Fax
<i>City campus</i>		
Foyer, Tower Building 1 Broadway	UTS Information Service PO Box 123 Broadway NSW 2007	Telephone: (02) 9514 1222 Fax: (02) 9514 1200
<i>Kuring-gai campus</i>		
Level 5 or 6, Main Building Eton Road Lindfield	Kuring-gai Student Centre PO Box 222 Lindfield NSW 2070	Telephone: (02) 9514 5555 Fax: (02) 9514 5032
<i>International Programs</i>		
Level 5, Tower Building 1 Broadway	International Programs PO Box 123 Broadway NSW 2007	Telephone: (02) 9514 1531 Fax: (02) 9514 1530

### Email inquiries

Within Australia – [info.office@uts.edu.au](mailto:info.office@uts.edu.au)

International – [intlprograms@uts.edu.au](mailto:intlprograms@uts.edu.au)

## PRINCIPAL DATES FOR 1998

### Autumn semester

#### January

- 2 Release of HSC results
- 9 Formal supplementary examinations for 1997 Spring semester students
- 9 Closing date for changes of preference to UAC from 1997 NSW and ACT HSC applicants
- 16 Final examination timetable for Summer session
- 23 Main round of offers to UAC applicants
- 26 Australia Day – public holiday
- 26 Public school holidays end
- 28 Closing date for changes of preference to UAC for final round offers
- 28-30 Enrolment of new undergraduate students at City campus (and 2-4 February)

#### February

- 2 Last day for continuing students to pay their 1998 service fees
- 2-4 Enrolment of new undergraduate students at City campus (and 28-30 January)
- 6 Final round of offers (UAC)
- 2-13 Formal examinations for Summer session
- 23 Release of results for Summer session
- 5-26 Enrolment of students at City campus

#### March

- 2 Classes begin
- 4-5 Enrolment (External award, Non-award and Exchange students)
- 13 Last day to enrol in a course or add subjects
- 20 Last day to pay HECS
- 30 Last day to apply to graduate in Spring semester 1998
- 31 Last day to apply for leave of absence without incurring student fees/charges<sup>1</sup>
- 31 Last day to withdraw from a subject without financial penalty<sup>1</sup>
- 31 HECS census date

#### April

- 9 Last day to withdraw from a course or subject without academic penalty<sup>1</sup>
- 9 Public school holidays begin
- 10 Good Friday
- 13-17 Vice-Chancellors' Week (non-teaching)
- 14-17 Graduation (Kuring-gai)
- 24 Provisional examination timetable available
- 25 Anzac Day – public holiday
- 27 Public school holidays end

#### May

- 1 Applications available for undergraduate courses where applicable
- 1 Applications open for available postgraduate courses for Spring semester 1998
- 4-15 Graduation (City)
- 15 Examination masters due
- 29 Closing date for undergraduate and postgraduate applications for Spring semester
- 29 Final examination timetable

#### June

- 8 Queen's Birthday – public holiday
- 12 Last teaching day of Autumn semester
- 13-30 Formal examination period (and 1-3 July)

#### July

- 1-3 Formal examination period (and 13-30 June)
- 3 Autumn semester ends
- 3 Public school holidays begin
- 6-10 Vice-Chancellors' Week (non-teaching)
- 13-17 Formal alternative examination period for Autumn semester students
- 20 Public school holidays end
- 24 Release of Autumn semester examination results; two days earlier via UniPhone™
- 27 Formal supplementary examinations for Autumn semester students

## Spring semester

### August

- 3 Classes begin
- 3 Applications available for undergraduate and postgraduate courses for Autumn semester 1999
- 7 Last day to withdraw from full year subjects without academic penalty<sup>1</sup>
- 14 Last day to enrol in a course or add subjects
- 31 Last day to apply for leave of absence without incurring student fees/charges (Spring enrolments only)<sup>1</sup>
- 31 Last day to withdraw from a subject without financial penalty<sup>1</sup>
- 31 Last day to apply to graduate in Autumn semester 1999
- 31 HECS census date

### September

- 11 Last day to withdraw from a course or subject without academic penalty<sup>1</sup>
- 25 Provisional examination timetable available
- 25 Public school holidays begin
- 28 Vice-Chancellors' Week (non-teaching) begins
- 28-30 Graduation (City)
- 30 Closing date for undergraduate applications via UAC (without late fee)
- 30 Closing date for inpUTS Special Admission Scheme applications

### October

- 1-2 Graduation (City)
- 2 Vice-Chancellors' Week (non-teaching) ends
- 5 Labour Day – public holiday
- 12 Public school holidays end
- 16 Examination masters due
- 30 Final examination timetable available
- 30 Closing date for undergraduate applications via UAC (with late fee)

- 30 Closing date for undergraduate applications direct to UTS (without late fee)
- 30 Closing date for most postgraduate courses for Autumn semester 1999 (some courses may have earlier closing dates in September)
- 30 Closing date for Australian Postgraduate Awards, the R L Werner and University Doctoral scholarships

### November

- 13 Last teaching day of Spring semester
- 14-30 Formal examination period (and 1-4 December)
- 30 Closing date for Undergraduate applications via UAC (with late fee)

### December

- 1-4 Formal examination period (and 14-30 November)
- 4 Spring semester ends
- 14-18 Formal alternative examination period for Spring semester students
- 18 Public school holidays begin
- 21 Release of Spring semester examination results; two days earlier via UniPhone™

---

<sup>1</sup> HECS/Postgraduate course fees will apply after the HECS census date (31 March and 31 August or last working day before).

**Note:** Information is correct as at 6 November 1997. The University reserves the right to vary any information described in Principal Dates for 1998 without notice.

# ***Faculty information***

---

## **MESSAGE FROM THE DEAN**

I am pleased to extend this welcome to you on behalf of all the staff of the Faculty of Mathematical and Computing Sciences at UTS. The Faculty continues to move forward on the many fronts that make up its mission. The last year has renewed the focus of the Faculty on high quality education for professionals in the era of globalisation.

The Faculty has an enviable array of programs at the Bachelor's level. The BSc (Computing Science), with its industry linked components, continues to produce graduates who are keenly sought by industry. The Bachelor of Mathematics and Finance provides the business community with graduates who take a highly analytical and rigorous approach to the problems of modern international finance. The Bachelor of Information Technology is now entering its tenth year. Students in this program receive generous stipends from companies who are eager in return to hire graduates of the very highest quality. Graduates of the BSc (Mathematics) are well equipped to approach business problems that require the application of the various branches of mathematics.

The Faculty has a commitment to life-long learning for experienced professionals. The Faculty offers a stable of postgraduate coursework and continuing professional education courses that are intended to satisfy various career development needs. In the last year the Management Development Program for IT professionals has gone from strength to strength, providing a unique opportunity for management education to those with substantial experience in the IT industry.

In 1998, the Faculty is launching two new postgraduate programs in partnership with industry and other UTS faculties. The graduate program in Internetworking aims to retrain practising IT people to support the explosive growth in Internet and Intranet technologies. The other new graduate program is in Interactive Multimedia. This program is multi-

disciplinary, equipping graduates with particular skills plus the multi-faceted understanding required for successful professional contributions within the emerging multimedia industry.

The Faculty is determined to develop an international outlook and to become a Faculty of high international standing. We believe our reputation and standards to be world class. Nonetheless, it is necessary to fashion our offerings in a way that is attractive to the international market. 1998 sees the first offering by the Faculty of a program tailored especially for the needs of international students – the Bachelor of Computing. This will be followed by new programs at the postgraduate level.

The Faculty continues to develop its impressive research profile. The last year has seen the recruitment of two new professors. Professor Lynda Harvey will lead research and development in the increasingly important field of Information Systems. Professor Eckhard Platen is a joint appointment in Mathematical Finance with the Faculty of Business. He will provide leadership in research and course development in a field of vital significance to international industry.

In 1997, the Faculty graduated six PhD students – the highest number on record for the Faculty. The Faculty has approved a new Honours program for the BSc (Computing Science) that provides a pathway for students in Computing Sciences who wish to pursue research degrees.

There are many other activities and opportunities available within UTS that enrich the experience of university life. I commend these activities to you. Support services, provided by experienced and sympathetic staff, can help students through the difficult times that often arise. I hope that your time at UTS is both enjoyable and productive. I am confident that it will assist you in achieving both professional and personal success.

## **FACULTY MISSION STATEMENT**

The mission of the Faculty is to provide high-quality, innovative programs of teaching and learning, research and consulting, and continuing professional education to clients of wide backgrounds, both nationally and internationally, in the mathematical and computing sciences. It is committed to technology transfer for the benefit of society by interacting closely with industry, business and government in research and development.

To support its mission, the Faculty aims to:

### **Teaching and learning**

- maintain a comprehensive range of educational programs to satisfy the spectrum of needs in the community
- excel in both the quality of the learning environment and the professional relevance of its educational programs
- develop an international perspective to its teaching programs

### **Research and scholarship**

- excel in the quality of its research activities
- encourage and facilitate participation by all staff in research or scholarly activities while focusing its research activities onto its defined areas of strength and a small number of targeted areas for development
- increase the participation rate of students in postgraduate programs
- promote intra-faculty, interfaculty, national and international research collaboration
- emphasise to staff and students the benefits of an international perspective on their disciplines

### **Management and resources**

- assure the quality of activities within the Faculty through the ongoing monitoring and the continuous development of a range of quality control processes
- maintain a balanced portfolio of expertise within its staff, which reflects perceived trends within the industries and disciplines addressed by the Faculty
- seek supplementary sources of external funding through research, joint ventures and entrepreneurial activities
- ensure the principles of equity are observed in all aspects of the Faculty's work, with particular emphasis on the areas of importance identified in the UTS Equity Plan
- develop links with prestigious overseas universities and research institutions

### **Community service**

- preserve strong, effective links with industry, government, business, professional and community organisations
- improve credit transfer arrangements to facilitate the movement of properly prepared students who wish to transfer between universities, or who move into the university sector with prior education and knowledge.

## INFORMATION FOR STUDENTS

*Only new students and those enrolled in courses that have undergone major changes will receive a free handbook.*

The Faculty of Mathematical and Computing Sciences consists of two Schools – Mathematical Sciences and Computing Sciences. Together, these disciplines form the basis of ‘enabling technologies’ for applications in most other disciplines.

Each School teaches towards its own professional degrees from undergraduate through to Doctoral studies. Although student administration functions are centralised at faculty level, all the courses and much of the staff and research management are conducted at the school level. Each School has, as a consequence, developed its own management structure appropriate for the support of its teaching and research programs. Teaching is carried out across all campuses of the University.

The Faculty has a commitment to cooperative education, of both the work experience ‘sandwich’ form, and the cooperative scholarship format. The Faculty is active in research and has close liaison with industry in all aspects of its work.

The structure of the **School of Mathematical Sciences** reflects the orientation and emphases of its academic programs. There are three discipline groups:

- Mathematics
- Computational Mathematics
- Statistics and Operations Research

The School also provides a support service to all students of the University studying in various introductory mathematical or quantitative areas through its **Mathematics Study Centre**, under the directorship of Leigh Wood. The services of the Centre are available at the City and Kuring-gai campuses. Most of the teaching in the Centre occurs at an individual level and the Centre is open for at least 30 hours each week, with certain times devoted to particular areas of mathematics. Students can obtain help with individual problems specific to a particular course. Alternatively, students with more systematic problems may study in the Centre on a regular basis, obtaining assistance from a tutor as necessary.

The **University Statistical Consulting Service (USCS)**, a joint initiative of the School of Mathematical Sciences and the University Graduate School, has been established to provide a range of statistical services to support the research programs of UTS staff and graduate students. The Service, which is directed by Associate Professor Deborah Street, also offers its full range of service (which include both consultancy and short courses on statistical methods and software) to industry at a fee. At present, there are seven statisticians associated with the USCS. They have extensive consulting experience in the agricultural sciences and engineering, as well as in the design of biomedical trials, various areas of medical statistics, educational statistics, and the design and analysis of sample surveys.

The structure of the **School of Computing Sciences** reflects the orientation and emphases of its academic work. There are four discipline groups:

- Computer Systems
- Computing Methods
- Information Systems Technology
- Information Systems Management

The **Centre for Object Technology Applications and Research (COTAR)**, established in 1994, provides a focal point for the software industry using, or considering using, the new software development techniques of object technology. COTAR aims to promote and conduct research in object-oriented software engineering, object-oriented information systems and object-oriented computing. It provides not only a focus for such research and collaborative work with industry, but also high-quality professional development education. Further information can be obtained from the Head of School, Associate Professor Jenny Edwards.

The mission of the **CRC for Distributed Systems Technology (DSTC)** is to build the distributed information systems of the future through leading edge research, and to work with industry and government to apply and commercialise the results. The UTS participation in DSTC draws on expertise from the School of Computing Sciences and the Faculty of Engineering. The primary focus of the UTS research is on Quality of Service (QoS) and the delivery of multimedia information in real time within various distributed systems frameworks such as the World Wide Web, JAVA and CORBA. For further information contact Professor Michael Fry.

## Faculty Office contacts

Faculty Office staff are located on the third floor of Building 4, as indicated below. There is an Information Office at this location to assist students and the general public on course-related matters.

When telephoning from outside the University, all extension numbers should be prefixed by 9514.

Email addresses should be suffixed with '@mcs.uts.edu.au'.

	Ext	Bldg/ Room	Email	Student administration responsibility
<i>Dean</i>				
Professor M Fry	1801	4/343	mike	—
<i>Faculty Administrator</i>				
Vacant	1880	4/341	—	—
<i>Executive Assistant to the Dean</i>				
Lisa Gustowski	1800	4/342	lisa	—
<i>Executive Officer</i>				
Mr G C Goodwin-Moore	1308	4/335	gerard	—
<i>Professional Programs Manager</i>				
Ms A Stevens	1925	tba	alison	<i>Management Development Program</i>
<i>Technical Support Manager</i>				
Mr P Gale	tba	tba	tba	—
<b>Student administration</b>				
<i>Student Administration Manager</i>				
Ms L G McCoy	1867	tba	leanne	<i>All courses</i>
<i>Industry Liaison Officer</i>				
Mr D A Saunders	1804	tba	des	<i>BInfTech and Industrial Training</i>
<i>Graduate Administration Officer</i>				
Ms L Abraham	1806	tba	layla	<i>All postgraduate programs</i>
<i>Student Liaison Officers</i>				
Ms I Chu	1802	tba	ivy	<i>All BSc (Comp Sc)</i>
Ms J C Smith	tba	tba	josmith	<i>All BSc (Maths), BMathFin, and related Honours programs</i>
<i>Liaison Officers</i>				
Vacant	1803	4/335	—	<i>General inquiries</i>
Vacant	tba	tba	—	<i>General inquiries</i>
Vacant	tba	tba	—	



## Continuing Professional Education (CPE)

The Faculty offers a variety of CPE courses each semester.

The School of Computing Sciences offers courses in programming, such as Object-oriented Programming with C++, UNIX/C, Prototyping with Visual Basic, Programming on the Internet, and Electronic Commerce on the Internet, and professional courses in three-dimensional computer animation, database design, expert systems design and distributed databases, and client/server computing.

A range of CPE courses, such as the Introductory Statistics Workshop, are run under the auspices of the University Statistical Consulting Service. In addition, mathematics preparation courses such as Intensive Mathematics, Intensive Statistics and Preparation for Nursing are available through the Mathematics Study Centre.

Information on all CPE courses is available from the Faculty Information Offices on 9514 1803 or 9514 2246, or via the World Wide Web <http://www.socs.uts.edu.au/cpe>

## Sub-majors offered to students enrolled in other faculties

The Faculty offers a number of sub-majors to students enrolled in other faculties. Students wishing to enrol in a sub-major offered by the Faculty of Mathematical and Computing Sciences should first contact one of the Faculty Information Offices on 9514 1803 or 9514 2246.

In all cases, enrolment will be subject to students obtaining the permission of their home faculty, and their satisfying all prerequisite requirements.

Students should refer to the relevant School's 'Subject descriptions' section elsewhere in this handbook for prerequisite details.

### Sub-majors offered by the School of Mathematical Sciences

*The following sub-majors are currently available to students enrolled in any faculty.*

#### Mathematics (24cp)

The Mathematics sub-major provides a foundation of knowledge in mathematics sufficient for further development in the discipline and application to quantitative areas of business, particularly finance, and contributes key critical, analytical and quantitative skills.

#### Sequence

35101	Mathematics 1	6cp
35102	Mathematics 2	6cp
35212	Linear Algebra	6cp
35231	Differential Equations	6cp

#### Operations Research (24cp)

The Operations Research sub-major provides students with a level of knowledge necessary for application of the discipline in areas of relevance to business, particularly in mathematical programming (optimisation), scheduling and transportation, inventory analysis and financial modelling.

#### Sequence

33401	Introductory Mathematical Methods	6cp
35241	Optimisation 1	6cp
35340	Operations Research Practice	6cp
35344	Network Optimisation	6cp

#### Statistics (24cp)

The Statistics sub-major provides students with a level of knowledge necessary for application of the discipline in areas of relevance to business, particularly in the areas of regression methods, design and analysis of statistical experiments and stochastic processes.

#### Sequence

33401	Introductory Mathematical Methods	6cp
35252	Statistics 2	6cp
35353	Regression Analysis	6cp
35361	Probability and Stochastic Processes	6cp

### Sub-majors offered by the School of Computing Sciences

*The following sub-majors are currently available to students enrolled in any faculty.*

#### Business Analysis and Design/ Databases (30cp)

This sub-major provides students with a detailed knowledge of current, state-of-the-art databases – relational, object-oriented and distributed – and the analysis and design needed to use them.

#### Sequence

31424	Systems Modelling	6cp
31511	Systems Design	6cp
31434	Database Design	6cp
31443	Distributed Databases and Client/Server Computing	6cp
	<i>or</i>	
31921	Objectbases	6cp

**Business Information Technology (24cp)**

This sub-major provides students with a broad overview of the basics of computer hardware and software and major applications.

**Sequence**

31508	Programming Fundamentals	6cp
31424	Systems Modelling	6cp
31434	Database Design	6cp
31512	Networking 1	6cp

**Human Factors and Computing in Business (24cp)**

The sub-major on Human Factors and Computing in Business provides students with an insight into the effect that computers and information technology have on staff and the workplace, particularly in a climate of change.

**Sequence**

31424	Systems Modelling	6cp
31511	Systems Design <i>plus two of</i>	6cp
31737	Business Process Transformation	4cp
31777	Human-Computer Interaction	6cp
31950	Networked Enterprise Design	6cp

**Programming and Design (24cp)**

The Programming and Design sub-major provides students with skills in systems modelling and design, and object-oriented and procedural programming.

**Sequence**

31508	Programming Fundamentals	6cp
31424	Systems Modelling	6cp
31429	Procedural Programming	6cp
31434	Database Design	6cp

**Business Information Systems strand**

This strand is available to students as part of the Accounting major.

**Sequence**

31414	Information Systems	6cp
31424	Systems Modelling	6cp
31508	Programming Fundamentals	6cp
	<i>or</i>	
31434	Database Design	6cp

**Information Technology sub-major**

This sub-major is available to Information Studies students.

**Sequence**

31508	Programming Fundamentals	6cp
31424	Systems Modelling	6cp
31434	Database Design	6cp

31512	Networking 1	6cp
	Electives (chosen from Computing electives for which students have the prerequisites)	

**Information Technology major**

The Information Technology major is available to international students in the Faculty of Business and to students in the School of Mathematics.

**Sequence**

31414	Information Systems	6cp
31424	Systems Modelling	6cp
31509	Computer Fundamentals	6cp
31434	Database Design	6cp
31508	Programming Fundamentals	6cp
31512	Networking 1	6cp
	Electives (chosen from Computing electives for which students have the prerequisites)	

**Information Technology Specialisations in the MBA****Managing Information Technology**

This specialisation is for students with a first degree in Computing or equivalent. Choose any four subjects:

32204	Advanced Data Management	6cp
32206	Advanced Information Systems Modelling	6cp
32207	Information Management	6cp
32208	Information Processing Strategy	6cp
32402	Information Technology Environment	6cp
32503	Distributed Databases and Client/Server Computing	6cp
32509	Human Computer Interaction in Information Systems	6cp
32517	Commerce on the Internet	6cp
32526	Designing Networked Enterprise	6cp

**Applied Information Technology**

This specialisation is for students with little or no computing in their first degree.

	<i>compulsory</i>	
32607	System Analysis	6cp
32606	Database	6cp
	<i>choose two of the following</i>	
32517	Commerce on the Internet	6cp
32526	Designing Networked Enterprise	6cp
32207	Information Management	6cp
32208	Information Processing Strategy	6cp
32402	Information Technology Environment	6cp
31511	Systems Design	6cp
31508	Programming Fundamentals	6cp
31512	Networking 1	6cp

## International Studies electives

The Institute for International Studies at UTS offers electives in language studies, and in the study of contemporary societies in parts of the non-English-speaking world. All subjects last one semester and have a value of eight credit points.

### Language studies

All students wishing to engage in language studies as a credited part of their degree are required to enrol through the Institute for International Studies, whether the language studies are undertaken at UTS or elsewhere. The Institute teaches some language programs at UTS, has made arrangements with other universities for some languages to be taught to UTS students, and can make special arrangements for individual students to attend specific language programs where academic needs demand. The individual student's level of language proficiency before entry to the UTS program determines his or her level of language study. There is a range of entry levels to the various programs available. Most are available at beginner's and post-HSC levels, and some at more advanced levels.

The Institute for International Studies offers Language and Culture programs in Cantonese, Chinese, Indonesian, Japanese, Malaysian and Spanish on UTS campuses through arrangements with the Insearch Language Centre. Higher levels of these languages may be offered through arrangements with other universities in the Sydney area.

Croatian, French, German, Greek, Italian, Korean, Polish, Russian, Slovenian, Thai and Ukrainian are offered to UTS students through arrangements that have been made with other Sydney universities.

### Contemporary Society

The Institute also offers a series of subjects that provide an introduction to the contemporary societies, politics, economies and cultures of the countries of East and South-East Asia, Latin America and Western Europe, which are the areas of specialisation of the Institute.

The following majors are offered: Argentina, Australia and the Asia-Pacific Region, Chile, China, Croatia, France, Germany, Greece, Indonesia, Italy, Japan, Latin America, Malaysia, Mexico, Poland, Russia, Slovenia, South China, South-East Asia, Spain, Taiwan, Thailand and Ukraine. Details of the International Studies subjects are available in the *Institute for International Studies Handbook*.

Students should consult the Academic Administrator at the Institute for International Studies, UTS, 9 Broadway, Sydney, NSW 2007, telephone 9514 1574, fax 9514 1578, or the *Institute for International Studies Handbook*, for further details.

## Statement of good practice and ethics in informal assessment

### Aims of assignments

In many subjects offered by the Faculty, students undertake assessment tasks in the form of assignments. The setting of assignments is intended to promote a number of educational aims, including furthering each student's learning of the subject, particularly the acquisition of practical skills; providing a means for staff to assess each student's learning; providing feedback to the student on his or her progress in learning; and providing feedback to staff on the effectiveness of their teaching.

These aims can be subverted if students deceive staff about the authorship of their work.

### Acceptable behaviour

#### Using sources

Whenever anything from someone else's work is used, it is standard practice to indicate exactly where the information comes from. Acknowledgment is achieved by using a standard system of referencing, such as footnotes, end notes, the Harvard system etc. The *Guide to Writing Assignments* (available from the Co-op Bookshop) explains how to use all these standard systems of reference.

#### Collaboration

In some cases assignment guidelines may permit or require students to cooperate in developing a solution to part or all of an assignment. This may occur formally when a staff member assigns students to groups and indicates which components of the assignment they are to work on as a group and which components they are to work on individually.

It may also occur informally. For example, some assignments may involve an 'ideas gathering' phase followed by an 'execution' phase. Students may be permitted to collaborate informally on the preliminary phase(s), but be expected to work completely individually on the subsequent phase(s). In a programming assignment, for example, it is

normally acceptable for one student to discuss with another student (or other person) the specifications of the task so as to determine the requirements (see below). Whether this collaboration could extend to subsequent phases (such as the design phase) would depend on the assignment guidelines; normally, collaboration in the design and subsequent phases is not permitted.

Depending on the type of assignment and degree of collaboration permitted it is possible to define several categories of collaboration:

- individual effort (the student is required to work on all phases entirely by himself or herself);
- group effort (the student is required to work on all phases as part of a formal group);
- mixed effort (the student is required or permitted to work on some or all phases as part of a formal or informal group).

Unless assignment guidelines specifically state otherwise, **a student should assume that an assignment requires a completely individual effort.** The forms of cooperative collaborative behaviour that are acceptable under most circumstances are:

- discussing assignment specifications with another student (or other person) with a view to clarifying what is required;
- getting help from another student (or other person) on technical matters that are not directly part of the assessment task (e.g. on how to use some facility provided by the computer system, such as the editor);
- getting help from another student (or other person) in debugging a program. This is a common occurrence in computing; and
- obtaining help from a tutor.

Generally, what distinguishes the acceptable cases of collaborative behaviour from the unacceptable ones is the student's intention to deceive. For example, in an assignment requiring a completely individual effort, a student may encounter some snag, such as an unfamiliar compiler diagnostic. If the student were to seek help from another student (or person) to remove the snag, then this would normally be considered acceptable behaviour. If, however, several students designed and coded a solution together, then disguised this collaboration, that would be unacceptable behaviour.

## Unacceptable behaviour

### Outright lying

This is seen most often in programming assignments, where the program does not run, or runs incorrectly, yet the output handed in is correct. The output has been 'tailored' using a word processor in an attempt to fool the marker. Lying is never acceptable behaviour.

### Plagiarism

Plagiarism is the action of taking and using as one's own the thoughts, writings, or inventions of another with the intention to deceive.

For example, if one student in a computing subject were to obtain a copy of another student's (or other person's) program, were to modify parts of the program (e.g. change variable names) so as to disguise its origin, and then submit the modified program as his or her solution, then this would be considered plagiarism.

As another example, a student may obtain all or a major part of the solution to an assignment problem from a text book and, without acknowledging this, submit the solution as his or her own work.

As a further example, a student may use a source of information in an essay, without acknowledging the source. Such plagiarism may range from a sentence or two, or a table or diagram, to occasional cases where the entire paper consists of material copied from a book with only a few sentences added by the student. The student thus submits another's ideas as his or her own work.

Plagiarism is a form of cheating and is never acceptable.

### Collusion

Collusion occurs when a student combines with one or more other students (or other persons) to produce a common essay or solution to part or all of an assignment, disguises the shared origin of the solution, and submits the solution as his or her own individual work.

Collusion is regarded as a form of cheating and is never acceptable.

## Graduation ceremonies

University graduation ceremonies are held in the Autumn and Spring semesters of each year. All students should take note of the Academic Board policy on late approval of graduands which states that, 'any graduands who have

their results confirmed **after** the appropriate Academic Board meeting should **not** be eligible to graduate at the immediately forthcoming ceremony'. Any graduand who is approved, through exceptional circumstances, to attend a ceremony after the Academic Board deadline may not have his or her name included in the Graduation Program.

### **Environmental Health and Safety**

The Faculty has an Environmental Health and Safety Plan, copies of which are available from either Information Office, or on the School and Faculty World Wide Web pages. Staff and students should familiarise themselves with the plan and comply with all hazard procedures outlined in it.

The names and locations of First Aid Officers, and of first aid kits, are indicated by appropriate signs in Faculty and School areas.

### **Eligibility for Austudy**

Austudy provides financial help to full-time students who meet its income and assets requirements. Application forms and information about Austudy eligibility are available from offices of the Student Services Unit at the City and Kuring-gai campuses. **Students who receive Austudy and decide to drop subjects during the semester need to be aware that to remain eligible for Austudy they must be enrolled in a minimum of 18 credit points or have a HECS liability for the semester of .375.** The only exceptions made are for students with disabilities that interfere with their studies, students who are single supporting parents, or those who have been directed by the University to reduce their study load. Student Welfare Officers in the Student Services Unit can assist students who wish to apply for exceptions on these grounds.

### **Insearch Institute of Commerce**

The Insearch Institute of Commerce, which is wholly owned by the University of Technology, Sydney, offers a Diploma program in Information Technology. This program was designed by staff of the Faculty of Mathematical and Computing Sciences. While the University cannot guarantee admission to its degree programs, students who have completed this Diploma may apply for admission to the Bachelor of Science in Computing Science. If admitted, students may be granted up to one year's advanced standing. For further information contact the Admissions Manager, Insearch Institute of Commerce, Level 3, 187 Thomas Street, Haymarket; telephone 9281 8188, fax 9281 9875.

## LIST OF COURSES AND CODES

### School of Mathematical Sciences

Course title	Code
Bachelor of Mathematics and Finance	MM03
Bachelor of Mathematics and Finance (Honours)	MM04
Bachelor of Mathematics and Finance/ Bachelor of Arts in International Studies	MM06
Bachelor of Science in Mathematics	MM01
Bachelor of Science (Honours) in Mathematics	MM02
Bachelor of Science in Mathematics/ Bachelor of Arts in International Studies	MM05
Graduate Certificate in Mathematical Sciences	MM56
Graduate Diploma in Applicable Mathematics	MM67
Graduate Diploma in Mathematics and Finance	MM66
Graduate Diploma in Operations Research	MM52
Graduate Diploma in Statistics	MM65
Master of Science (by thesis)	MM51
Master of Science in Operations Research (by coursework)	MM53
Doctor of Philosophy	MM54

### School of Computing Sciences

Course title	Code
Bachelor of Computing	MC06
Bachelor of Computing/Bachelor of Arts in International Studies	MC07
Bachelor of Information Technology	MC03
Bachelor of Science in Computing Science	MC02
Bachelor of Science (Honours) in Computing Science	MC08
Bachelor of Science in Computing Science/ Bachelor of Arts in International Studies	MC05
Bachelor of Science in Computing Science/Bachelor of Laws	LL06
Graduate Certificate in Human-Computer Interaction	MC65
Graduate Certificate in Information Technology	MC67
Graduate Certificate in Information Technology Management	MC63
Graduate Certificate in Interactive Multimedia	MC72
Graduate Certificate in Internetworking	MC82
Graduate Diploma in Information Technology	MC52
Graduate Diploma in Information Technology Management	MC75
Graduate Diploma in Interactive Multimedia	MC71
Graduate Diploma in Internetworking	MC81
Master of Business in Information Technology Management (by coursework)	MC85
Master of Interactive Multimedia	MC70
Master of Science (by thesis)	MC51
Master of Science in Computing (by coursework)	MC53
Master of Science in Internetworking	MC80
Doctor of Philosophy	MC54

All inquiries regarding courses should be directed to the Faculty Information Offices on 9514 1803 or 9514 2246.

# Mathematical Sciences

The School of Mathematical Sciences offers four courses leading to Bachelor's degrees, postgraduate courses leading to qualifications at the Graduate Certificate, Graduate Diploma and Master's levels, and two research degree programs leading to Master's and Doctoral level qualifications. They are:

- the Bachelor of Mathematics and Finance, which is a three-year Pass degree with a fourth year Honours degree, offered in conjunction with the School of Finance and Economics;
- the combined Bachelor of Mathematics and Finance and Bachelor of Arts in International Studies which is a five-year degree, with an additional year of advanced study to fulfil the requirements of the Bachelor of Mathematics and Finance (Honours) degree, offered in conjunction with the Institute for International Studies and the School of Finance and Economics;
- the Bachelor of Science in Mathematics, which is a three-year Pass degree with a fourth year Honours degree;
- the combined Bachelor of Science in Mathematics and Bachelor of Arts in International Studies which is a five-year degree, with an additional year of advanced study to fulfil the requirements of the Bachelor of Science in Mathematics (Honours) degree, offered in conjunction with the Institute for International Studies;
- the Graduate Certificate in Mathematical Sciences;
- the Graduate Diploma in Applicable Mathematics;
- the Graduate Diploma in Mathematics and Finance;
- the Graduate Diploma in Operations Research;
- the Graduate Diploma in Statistics;
- the Master of Science in Operations Research (by coursework);
- the Master of Science, which is awarded on the basis of supervised research and presentation of a thesis; and

- the Doctor of Philosophy, which is awarded on the basis of supervised research and presentation of a thesis.

## Computing facilities

The School of Mathematical Sciences owns and operates five computing laboratories for the use of students enrolled in its courses.

Several of these laboratories are connected via the School's Novell network to the University network. The IBM style PCs in these laboratories can provide terminal or X-terminal connections to UNIX systems in the University, as an alternative to using the various public access laboratories provided by the University's Information Technology Division. The laboratories also provide *Mathematica* and a range of software for statistical and operations research applications, and for the teaching of computer graphics.

The School's facilities include two Pentium-based Windows NT laboratories, to support teaching and research in statistics, operations research and mathematics. Most specialist mathematical software is run using these laboratories, which include access to a Postscript laser printer. The School's library, available for the use of staff and research students, includes a high-quality graphics workstation from Silicon Graphics running UNIX, and a Windows PC for access to the network. All staff offices have network access and Windows 95 PCs.

Extensive use is made of the University's central facilities, which consist of a number of large Sun server systems. These can be accessed from public access laboratories throughout the University.

The School is actively involved in two major regional computing consortiums. The NSW Centre for Parallel Computing operates a Silicon Graphics Power Challenge parallel computer, located at the Australian Technology Park. The Vislab Consortium provides scientific visualisation research facilities via the University of Sydney and the Australian Technology Park, and local nodes located at each of the partner institutions, including UTS.



## University Statistical Consulting Service

The University Statistical Consulting Service (USCS) aims to provide statistical advice to research workers at UTS and to industrial clients. It is a joint initiative of the School of Mathematical Sciences and the University Graduate School. There are seven statisticians associated with the USCS. They have had extensive consulting experience with agricultural scientists, with engineering firms, in the design of biomedical trials and other aspects of medical statistics, in educational statistics, and in the design and analysis of sample surveys.

The major areas of expertise of the USCS are:

- design and analysis of experiments
- design of clinical trials
- analysis of data from biomedical areas
- engineering statistics
- quality control and quality management issues
- design and analysis of sample surveys
- data-based forecasting and prediction

The policy of the USCS is to encourage research workers at UTS to become self-sufficient in the carrying out of routine statistical analyses. Consultants will act in an advisory capacity, offering assistance with the planning and design of experiments and surveys, and with the interpretation of analyses, and will carry out non-routine analyses. Courses on statistical methods for research workers will be conducted by the consultants from time to time.

Routine statistical analyses are best carried out using statistical packages such as Minitab, SAS and SPSS. Courses on these packages will be conducted by the consultants from time to time.

All research workers, including postgraduate students, are encouraged to see a member of the USCS during the planning stage of their research programs. This will ensure that experiments are correctly designed to answer the research workers' questions, that efficient use is made of resources and that the results are recorded in a form appropriate for future analysis. To assist the consultant, the research worker is requested to provide a written summary of the proposed research project, clearly stating the aims of all experiments. For

postgraduate students, supervisors should participate in the initial meetings and in the interpretation of the results.

While all reasonable efforts will be made to complete the analysis expeditiously, no definite time can be estimated for the completion of an analysis and no guarantee can be given that useful results will be obtained.

The staff of the USCS are Associate Professor Deborah Street, Director, Dr Tania Prvan, Senior Lecturer, and Ms Jacqueline Allen, Assistant Statistical Consultant.

## Mathematics Study Centre

Through its Mathematics Study Centre, the School of Mathematical Sciences provides a support service to all students of the University studying in various introductory mathematical or quantitative areas including statistics. The Mathematics Study Centre coordinates all mathematics support services across the University, and is available on both the City and Kuring-gai campuses.

### Drop in service

The Centre is open each day during semester, including tutorial and study weeks. It is open two nights a week on the City campus to cater for part-time students. Students can drop in to the Centre to obtain help with problems specific to a particular course or they may choose to study in the Centre on a regular basis, obtaining assistance from a lecturer as needed. A timetable of Centre lecturers with their particular areas of expertise is available from both branches of the Centre.

### Tutorial support

The Mathematics Study Centre offers extra support tutorials for students who have difficulty with their mathematics and statistics studies at first-year level. Where a need exists, students enrol in one of the subjects listed below. This can be arranged separately for students in any faculty; the subjects have previously been run for students in Mathematical Sciences, Engineering, Business, Nursing, Teacher Education and Information Studies. Students may only enrol in one subject of the same number in each semester.

**94434, 94435, 94436****Mathematics Tutorial 1, 2, 3**

These subjects consist of approximately one hour tuition per week during semester time. These subjects are free of HECS charges and carry no credit point value.

**94437, 94438, 94439****Mathematics Study 1, 2, 3**

These subjects consist of approximately two hours tuition per week during semester time. These subjects are free of HECS charges and carry no credit point value.

**Workshops**

The Centre runs Saturday workshops during semester and in the final examination period for many first-year mathematics and statistics subjects. They are timed to assist students in their preparation for quizzes and the final examination, and are popular with students from all faculties. Students may only enrol in one subject of the same number in each semester.

**94431, 94432, 94433, 94440, 94441, 94442****Mathematics Workshop 1, 2, 3, 4, 5, 6**

These subjects consist of approximately six hours of instruction, usually on a Saturday. These subjects are free of HECS charges and carry no credit point value.

**Individual assistance**

It is possible for students to arrange individual assistance with mathematics. This is particularly appropriate if a student has a record of failure in mathematics subjects or suffers from low self-confidence. It is also appropriate for students with disabilities. If required, arrangements may be made for a student to have an individual tutorial each week. Much of this is done with counselling support from Student Services.

**Bridging subjects**

The Mathematics Study Centre provides bridging subjects for students who need mathematics skills for their degree studies at UTS. If faculties have particular needs, Centre staff can design a bridging subject specifically to meet these needs.

**94450****Introduction to Statistics**

This is a 12-hour subject, run over four evenings in February and also on four days in July, and is designed for students about to enter introductory statistics or research methods subjects. It is particularly popular with Information Studies students. This subject is free of HECS charges and carries no credit point value.

**94470****Introduction to Computers for Beginners**

This is a 12-hour subject, run day and evening in February. It is designed for students who are not familiar with computers and aims to develop confidence, an understanding of terminology and some basic skills. This subject is free of HECS charges and carries no credit point value.

**94480****Bridging Mathematics**

This is a 24-hour subject, run day and evening over two weeks in February between enrolment and the start of classes. It provides prerequisite mathematics skills at 2/3 Unit HSC level and is aimed at mature-age students, students who have studied mathematics overseas and students who have not studied a high enough level of mathematics at school for their needs. This subject is free of HECS charges and carries no credit point value.

**94490****Mathematics Preparation for Nursing**

This is a 12-hour subject, run day and evening in February. It gives a general introduction to mathematics and science for students entering Nursing. This subject is free of HECS charges and carries no credit point value.

**Preparation courses**

The Centre runs three fee-paying courses each year to prepare students for university studies the following year. Students completing these courses have had success in gaining entry to university and in completing their degree studies.

*Intensive Mathematics* begins in July and runs for 15 weeks on two nights per week. The course covers the content of the HSC 2 Unit mathematics course and prepares students for entry into mathematics-based courses, such as Engineering and Science.

*Intensive Statistics* begins in July and runs for 15 weeks on two nights per week. The course is designed for people who will be studying statistics subjects as part of their tertiary studies or whose occupations involve the use of statistical information. No previous knowledge of statistics is assumed.

*Preparation for Nursing* is a course aimed at giving potential Nursing students the prerequisite knowledge in mathematics and science for their degree studies. This course runs in October and November each year.

### Location

City campus: Building 1, Room 1615  
Kuring-gai campus: Room K2-522

### Opening hours

Monday to Friday during semester, including tutorial and study weeks. The Centre will be open on some evenings to cater for part-time students. Detailed timetables are available at the Centre.

### Contact details

For further information, students should contact the Director of the Mathematics Study Centre, Leigh Wood, telephone 9514 2268, email L.Wood@maths.uts.edu.au

## Mathematica

The University has recently acquired a site licence for the computer algebra system *Mathematica*. This software permits the integration of symbolic, graphical and numerical computation with a modern programming environment. It is ideally suited to teaching and research in any mathematically-based area of interest.

The system is being introduced into many of the subjects offered by the School. Students' exposure to *Mathematica* begins in the first semester of the BSc and BMathFin degree programs and knowledge of the system expands as the course develops. By the time of graduation, all students will have acquired considerable expertise in the use of this software.

### Subject exemptions

Students undertaking courses offered by the School and who have successfully completed subjects at other tertiary institutions, may be eligible for exemptions where the subjects previously studied are deemed to be equivalent to those specified for the current course. Eligibility is determined by the Faculty

and follows University Rule 2.28, on Advanced Standing. The rule is given in full in the University Calendar.

Students should apply for exemptions at enrolment or immediately following enrolment. Students applying for exemptions should complete all details on the Application for Subject Exemption form which is available from the University Information Centre (Level 4, Building 1) or the Faculty Office (Level 15, Building 1). Original transcripts must be sighted or certified copies attached to support the application. A copy of the other institution's handbook or relevant subject syllabuses must be produced on request. The form and supporting materials should then be taken to the Exemptions Coordinator. It is preferable that such requests are made in person should further clarification be required. Further information can be obtained from the Faculty Office.

## PRIZES

The School of Mathematical Sciences awards the following prizes on a yearly basis.

### Foundation for Australian Resources Prizes

The Foundation for Australian Resources is an independent non-profit organisation whose nominated beneficiary is the Faculty of Mathematical and Computing Sciences. The Foundation has made available three prizes to students enrolled in courses run by the School of Mathematical Sciences. One prize, valued at \$250, is for the best graduating student from the Bachelor of Science (Honours) in Mathematics degree. The other two, valued at \$100 each, are awarded to the outstanding first-year full-time student enrolled in either the Bachelor of Science in Mathematics or the Bachelor of Mathematics and Finance program, and to the outstanding part-time student enrolled in Stage 1 of either of these programs.

### Macquarie Bank Scholarship

The Macquarie Bank has provided a scholarship to the student obtaining the highest weighted average mark in the standard full-time program of the first year of the Bachelor of Mathematics and Finance degree, provided that mark exceeds 75. Each scholarship has a value of \$7,500 and is disbursed as three sums of \$2,500, one for each year of the course.

**Sam Huxham Memorial Prize**

This prize was established in 1994 in memory of Samuel Hugh Huxham, who joined the NSW Institute of Technology in 1971 and was Head of the Statistics and Operations Research Unit at the time of his death in May 1994. It is awarded each year for the best performance in the Statistics major by a student completing the Bachelor of Science in Mathematics degree in the preceding year. The prize has a cash value of \$250.

**Statistical Society of Australia Prize in Statistics**

In 1980 the Statistical Society of Australia NSW Branch established a prize for excellence in Statistics. This prize is now awarded to the student who is first in order of merit of those students completing the Statistics strand of the Bachelor of Science (Honours) in Mathematics degree. The prize is a cash award of \$200.

**School contacts**

All staff of the School of Mathematical Sciences are located on Levels 15 and 16 of the Tower Building (Building 1) on the City campus (Broadway).

When telephoning from outside the University, all extension numbers should be prefixed with 9514.

All email addresses should be suffixed with '@maths.uts.edu.au'.

Name	Ext	Room	Email
<i>Assistant Statistical Consultant</i> Ms Jacqueline Allen	2273	1555	J.Allen
Associate Professor Lindsay Botten	2247	1528	L.Botten
<i>Deputy Head of School, Director, Postgraduate Studies, and Head, Mathematics Unit</i> Associate Professor Graeme Cohen	2262	1520	G.Cohen
<i>inpUTS Coordinator for students with special needs and Academic Liaison Officer</i> Ms Mary Coupland	2241	1535	M.Coupland
Mr Peter Coutis	2268	1536	P.Coutis
<i>Exemptions Coordinator</i> Ms Layna Groen	2266	1533	L.Groen
Dr Jules Harnett	5186	K2-522	J.Harnett
Ms J Hayne	5186	K2-522	J.Hayne
Dr Ian Hoffman	2244	1545	I.Hoffman
<i>Graduate Certificate Coordinator</i> Mr Jeff Hogg	2238	1524	J.Hogg
Dr Tim Langtry	2261	1537	T.Langtry
<i>Electives Coordinator</i> Mr Ed Lidums	2235	1530	E.Lidums
<i>Computer Systems Support Officer</i> Mr Eric Lindsay	2254	1618	E.Lindsay
<i>Systems Programmer</i> Mr Gordon Lingard	—	—	—
Dr Beverley Moore	2258	1550	B.Moore

Name	Ext	Room	Email
<i>Head of School</i>			
Associate Professor Gordon McLelland	2259	1520	G.McLelland
Mr Ken Ozanne	2256	1538	K.Ozanne
<i>Head, Computational Mathematics Unit</i>			
Mr Larry Park	2278	1560	L.Park
<i>Honours Coordinator</i>			
Dr Peter Petocz	2264	1531	P.Petocz
Professor Eckhard Platen	2271	1527	E.Platen
Mr Denis Porteus	2265	1559	D.Porteus
Mr Bob Rozsasi	2245	1561	B.Rozsasi
<i>Director, Undergraduate Studies</i>			
Dr Geoff Smith	2236	1532	G.Smith
Ms Narelle Smith	2239	1539	N.Smith
<i>Head, Statistics and Operations Research Unit, and Director, University Statistical Consulting Service</i>			
Associate Professor Deborah Street	2251	1540	D.Street
Mr Ron Sorli	2281	1548	R.Sorli
Mr Brian Stephenson	2267	1547	B.Stephenson
Professor Barry Thornton	2252	1541	B.Thornton
<i>Director, Mathematics Study Centre</i>			
Ms Leigh Wood	2268	1536	L.Wood
<i>Executive Assistant to Head of School</i>			
Vacant	2249	1520	—
Mr Peter Wright	2243	1546	P.Wright
Dr Yakov Zinder	2279	1523	Y.Zinder

# Undergraduate courses

## Bachelor of Science in Mathematics

### Course code: MM01

This degree aims to prepare students for employment in industry, commerce and government and to provide the foundation for higher studies in mathematics. It provides great flexibility by allowing students to follow a course of study which best suits their interests and aspirations. It aims to help students acquire sufficient experience and understanding in a broad range of mathematical disciplines to enable them to apply mathematical and computing techniques to industrial and commercial problems.

The course operates as a three-year Pass degree with a fourth year Honours degree. The basic structure of the Pass degree is as follows:

**The core** – this provides a thorough grounding in the elements of mathematics, statistics, operations research, computing and their applications. This component occupies half of the Pass degree and is taught predominantly during the first two years of the full-time program.

**The major** – this occupies half of Year 3 of the full-time course (or Years 5 and 6 of the part-time course) and may be taken in one of the areas of pure or applied mathematics, statistics or operations research. This framework provides for specialised study of a particular area of application. A major in Operations Research involves topics such as linear programming, simulation, optimisation and financial modelling. The Statistics major aims to expose students to realistic statistical problems, preparing them to cope with data and their associated uncertainty and variability. The Mathematics major develops further geometric, analytic and algebraic tools and applies them in a variety of complex and practical situations.

**Electives** – these occupy one-third of the course and, subject to certain restrictions, may be subjects from any school of the University chosen by students to

strengthen their understanding in areas of their choice. Common choices are the Computing major offered by the School of Mathematical Sciences, an additional major in mathematics, or a sub-major in computing, finance or one of the sciences.

The Computing major provides students with both practical and theoretical training in computer science and its mathematical foundations, information systems and commercial computing, and a wide variety of applications. Because this major occupies the entire elective sequence, students who wish to pursue it are advised to commence it in their first year of study. However, because it is an elective major, students are not obliged to follow it to completion. The major is accredited at Level 1 by the Australian Computer Society and, accordingly, those who complete it are eligible for Associate Membership of that Society. Students who do not wish to complete the entire major may instead take the Computing sub-major, described in the 'Sub-majors' section.

The course may be attempted on either a full-time or a part-time basis. The standard full-time load is 24 credit points per semester (typically, four subjects each worth six credit points) and the standard part-time load is 12 credit points per semester (typically, two subjects both worth six credit points). Most mathematics subjects worth six credit points involve four hours of class contact per week (typically, three hours of lectures and one hour of tutorial), although some first-year subjects have a higher contact load of six hours. Some subjects, especially those in computing, have additional laboratory hours.

Part-time students will be accommodated by the provision of evening classes for most subjects. It is expected that part-time students will be able to attend classes on one afternoon and three evenings per week during the first two years of the course, and on one afternoon and two evenings per week during later years. Part-time students taking the Computing major may be required to attend a laboratory class on one additional evening per week for some later subjects.

As a general rule, for any given subject, it is wise to devote to home study the same number

of hours per week as are allocated to lectures and tutorials in the case of first-year subjects, and twice the number of hours associated with lectures and tutorials per week for more senior subjects.

Details of individual subjects can be found in the 'Subject descriptions' section for the School of Mathematical Sciences in this handbook.

### Grading of awards

The School of Mathematical Sciences does not grade students eligible to receive the Bachelor of Science in Mathematics degree.

### Honours degree

Students contemplating taking Honours are advised to consult the Honours Coordinator or the Director, Undergraduate Studies, on completing the core of the Bachelor of Science in Mathematics degree.

### Course program

#### Full-time program

##### Year 1

##### Autumn semester

35100	Mathematical Practice	3cp
35101	Mathematics 1	6cp
35111	Discrete Mathematics	3cp
35170	Introduction to Computing	6cp
	Electives	approx. 6cp

##### Spring semester

35102	Mathematics 2	6cp
35151	Statistics 1	6cp
	Electives	approx. 12cp

##### Year 2

##### Autumn semester

35212	Linear Algebra	6cp
35231	Differential Equations	6cp
35232	Advanced Calculus	6cp
	Electives	approx. 6cp

##### Spring semester

35241	Optimisation 1	6cp
35252	Statistics 2	6cp
35281	Numerical Analysis 1	6cp
	Electives	approx. 6cp

##### Year 3

##### Autumn semester

35321	Analysis 1	6cp
	Major 1	6cp
	Major 2	6cp
	Electives	approx. 6cp

#### Spring semester

	Major 3	6cp
	Major 4	6cp
	Electives	approx. 12cp

#### Part-time program

##### Year 1

##### Autumn semester

35100	Mathematical Practice	3cp
35111	Discrete Mathematics	3cp
	Electives	approx. 6cp

##### Spring semester

35170	Introduction to Computing	6cp
35101	Mathematics 1	6cp

##### Year 2

##### Autumn semester

35102	Mathematics 2	6cp
	Electives	approx. 6cp

##### Spring semester

35212	Linear Algebra	6cp
	Electives	approx. 6cp

##### Year 3

##### Autumn semester

35151	Statistics 1	6cp
	Electives	approx. 6cp

##### Spring semester

35231	Differential Equations	6cp
35232	Advanced Calculus	6cp

##### Year 4

##### Autumn semester

35241	Optimisation 1	6cp
35252	Statistics 2	6cp

##### Spring semester

35321	Analysis 1	6cp
	Electives	approx. 6cp

##### Year 5

##### Autumn semester

35281	Numerical Analysis 1	6cp
	Major 1	6cp

##### Spring semester

	Major 2	6cp
	Electives	approx. 6cp

##### Year 6

##### Autumn semester

	Major 3	6cp
	Electives	approx. 6cp



**Spring semester**

Major 4	6cp
Electives	approx. 6cp

**Major areas of study**

Students must complete at least one of the majors in the areas of Statistics, Operations Research or Mathematics. Students may also choose to complete the Computing major.

**Mathematics major**

Two sequences, one in Pure Mathematics and one in Applied Mathematics, are offered, although it is not expected that all subjects in both sequences would be taught in any one year. Students may be required to choose a program combining subjects from both sequences. Students interested in the Mathematics major should discuss their enrolment with the Director, Undergraduate Studies, late in the year preceding their intended enrolment.

**Pure Mathematics sequence**

Full-time program Year 3 and part-time program Years 5 and 6

**Autumn semester**

35313 Pure Mathematics 3A	6cp
35335 Mathematical Methods	6cp

**Spring semester**

35314 Pure Mathematics 3B	6cp
35322 Analysis 2	6cp

**Applied Mathematics sequence**

Full-time program Year 3 and part-time program Years 5 and 6

**Autumn semester**

35333 Applied Mathematics 3A	6cp
35335 Mathematical Methods	6cp

**Spring semester**

35334 Applied Mathematics 3B	6cp
35382 Numerical Analysis 2	6cp

**Statistics major****Full-time program**

Year 3

**Autumn semester**

35356 Design and Analysis of Experiments	6cp
35361 Probability and Stochastic Processes	6cp

**Spring semester**

35353 Regression Analysis	6cp
35355 Quality Control	6cp

**Part-time program**

Year 5

**Autumn semester**

Core subject	
35356 Design and Analysis of Experiments	6cp

**Spring semester**

35361 Probability and Stochastic Processes	6cp
Electives	approx. 6cp

Year 6

**Autumn semester**

35353 Regression Analysis	6cp
Electives	approx. 6cp

**Spring semester**

35355 Quality Control	6cp
Electives	approx. 6cp

**Operations Research major****Full-time program**

Year 3

**Autumn semester**

35342 Optimisation 2	6cp
35361 Probability and Stochastic Processes	6cp

**Spring semester**

35340 Operations Research Practice	6cp
35363 Simulation Modelling	6cp

**Part-time program**

Year 5

**Autumn semester**

Core subject	
35342 Optimisation 2	6cp

**Spring semester**

35361 Probability and Stochastic Processes	6cp
Electives	approx. 6cp

Year 6

**Autumn semester**

35363 Simulation Modelling	6cp
Electives	approx. 6cp

**Spring semester**

35340 Operations Research Practice	6cp
Electives	approx. 6cp

## Computing major

The two elective subjects in the Major may be any subjects offered by the School of Computing Sciences, for which the prerequisites have been satisfied, and which do not contain material otherwise covered in the Major.

### Full-time program

#### Year 1

##### Autumn semester

31414 Information Systems 6cp

##### Spring semester

31424 Systems Modelling 6cp

31508 Programming Fundamentals 6cp

#### Year 2

##### Autumn semester

31434 Database Design 6cp

##### Spring semester

31509 Computer Fundamentals 6cp

#### Year 3

31512 Networking 1 6cp

Computing electives 12cp

### Part-time program

#### Year 1

##### Autumn semester

No Computing Major subjects

##### Spring semester

31414 Information Systems 6cp

#### Year 2

##### Autumn semester

31424 Systems Modelling 6cp

##### Spring semester

31508 Programming Fundamentals 6cp

#### Year 3

##### Autumn semester

31509 Computer Fundamentals 6cp

##### Spring semester

No Computing Major subject

#### Year 4

##### Autumn semester

No Computing Major subjects

##### Spring semester

31434 Database Design 6cp

#### Years 5 and 6

31512	Networking 1	6cp
	Computing electives	12cp

## Transition arrangements from the pre-1998 Computing major

In 1997, changes were made to the Computing Major to take effect from Autumn semester 1998. Details of the previous structure are presented in the 1997 Faculty Handbook, and are available from the Faculty Office.

Transition arrangements for students who have partially completed the Major, at the end of 1997, will be as follows. For students who have completed the subject 35171 Computing 1 by the end of 1997, this subject may be substituted for the subject 31508 Programming Fundamentals. For students who have completed the subject 35272 Computing 2 by the end of 1997, the third year full-time subjects of the previous Major will be offered in 1998. Students in this situation, who are unable to complete the Major by the end of 1998, will be dealt with on an individual basis.

## Electives

Electives occupy one-third of the BSc in Mathematics degree and may be chosen by students to strengthen or develop their knowledge in an area of their choice. Electives are split into **free electives** and **structured electives**.

### Free electives

Free electives, whose total weight cannot exceed 24 credit points, provide students with an opportunity to select subjects which accommodate their various interests and needs in a less formal manner than is the case for structured electives. These subjects can be taken from any school within the University, or from another university if the subject area is not represented at UTS. The choice of free electives must be discussed with academic advisers and must be approved by the Electives Coordinator, who will ensure that no subjects specifically proscribed by the School are included. The proscribed list includes subjects of a mathematical nature which are taught elsewhere in the University, and which provide coverage of material that is already incorporated in subjects offered by this School.

Subjects offered by the School of Mathematical Sciences and not included in a student's chosen

major may also be taken as free electives. In addition, the following subjects may be chosen:

35106	Mathematics in Sport	6cp
35205	History of Mathematics	6cp
35254	Health Statistics	6cp
35292-6	Project	2-6cp
35344	Network Optimisation	6cp
35384	Financial Modelling	6cp
35391	Seminar (Mathematics)	6cp
35392	Seminar (Operations Research)	6cp
35393	Seminar (Statistics)	6cp
35394	Seminar (Computing)	6cp

**Note:** The subject 35384 Financial Modelling is not available to students taking the Operations Research major or the Finance sub-major.

The subject 35106 Mathematics in Sport is available only in the Summer session.

### Structured electives

Structured electives, whose total weight shall not be less than 24 credit points, provide an opportunity for students to systematically develop knowledge of some discipline of their choice. The possibilities are:

- the Computing major (see above);
- a second major within the BSc in Mathematics degree, other than the Computing major;
- the Computing sub-major offered by the School of Mathematical Sciences (not available to students who complete the Computing major);
- existing majors or sub-majors within the University, that have been approved by the School as appropriate for use as structured electives;
- subject sequences which provide for the systematic development of a topic but which are not recognised formally as either a major or sub-major. These sequences must be negotiated between the students and their academic advisers and approved by the Electives Coordinator.

### Sub-majors

The following are available as sub-majors. In all cases, full details are available from the Faculty Office.

#### Computing sub-major

31508	Programming Fundamentals
31509	Computing Fundamentals <i>and any two of</i>
31512	Networking 1
31414	Information Systems
31424	Systems Modelling
31434	Database Design

### Sub-majors offered by other faculties

Students may elect to do sub-majors offered by other faculties. It is necessary to discuss the choice with the Electives Coordinator in the School of Mathematical Sciences, and to obtain appropriate approval from the faculty concerned. The following are possible sub-majors.

#### Aboriginal Studies sub-major

The faculties of Humanities and Social Sciences and Education offer a range of Aboriginal Studies subjects that may be taken as a sub-major, or as elective subjects, as appropriate, within any undergraduate course.

The sub-major provides Aboriginal and non-Aboriginal students with an opportunity to study subjects that are culturally appropriate to an understanding of Aboriginal culture, history and social/political structures. These initial studies serve as a basis for applying critical analysis skills to Aboriginal and non-Aboriginal perspectives on issues and trends which affect the cultural and social integrity of Aboriginal peoples. Consideration is also given to other indigenous people, including Torres Strait Islanders. The role of the media and written or spoken communication are the major focuses of these analyses.

015110	Aboriginal Cultures and Philosophies	8cp
54230	Aboriginal Social and Political History <i>plus at least one of</i>	8cp
54231	Aboriginal People and the Media	8cp
54330	The Politics of Aboriginal History	8cp
54331	Aboriginal Forms of Discourse	8cp

#### Finance sub-major

The School of Finance and Economics offers a sub-major in Finance consisting of 30 credit points. To ensure completion of this sub-major it is normally necessary to commence it in the Autumn semester of Year 1.

#### Physics sub-majors

The Department of Applied Physics offers two sub-majors, one in Physics and one in Electronics. Both contain two compulsory subjects. The remaining subjects, with a value totalling eight credit points (or more), must be chosen from a selection of subjects appropriate to the field.

#### International Studies sub-majors

The Institute for International Studies offers three sub-majors in Specialist Country Studies and Languages Other Than English. Each consists of three 8 credit point subjects.

## Bachelor of Science (Honours) in Mathematics

**Course code: MM02**

The Honours degree provides the opportunity for students to develop their level of competence in the area of mathematics chosen as their major in the BSc in Mathematics degree. The Honours degree is offered over one year on a full-time basis, or two years on a part-time basis, and consists of advanced coursework (comprising two-thirds of the program) and a thesis. This thesis allows students to use the expertise developed by their coursework in an area of application. Students who complete the Honours degree will accordingly be well prepared to enter the workforce at a high level or to undertake graduate studies.

The precise selection of subjects to be offered in any particular year will depend on the interests of students, and the interests and availability of staff. Students should consult the Honours Coordinator, who will assist them in planning their program. This is of particular importance for part-time students since few subjects will be offered at night.

Admission to the Honours degree will be assessed individually according to the following criteria:

- Students who are eligible to graduate from the BSc in Mathematics degree with an average mark of 65 or more in Year 2 (full-time) of the core and in their chosen major, will be eligible for entry to the Honours degree.
- Students who have obtained qualifications equivalent to the BSc in Mathematics degree will, upon application, be considered for entry by the Head of the School of Mathematical Sciences, on the basis of assessed potential to complete the Honours degree.

The Honours program will require the completion of subjects worth 48 credit points in one year of full-time study, or two years of part-time study. Honours will be offered in the Mathematics, Statistics and Operations Research strands, although some strands may not be offered in a given year. The program will consist of eight coursework subjects, each

of four credit points, and a thesis of 16 credit points.

Students contemplating taking Honours are advised to consult the Honours Coordinator or the Director, Undergraduate Studies, on completing the core of the BSc in Mathematics degree. This will enable them to plan studies for the following years and make decisions at an early stage which will not close off options that otherwise would be available to them. Usually students decide to apply for Honours before the completion of the BSc in Mathematics but, under the structure of the course, entry to Honours is possible even if the decision to do so is delayed until completion of the BSc in Mathematics.

The Honours degree consists of:

- 24 credit points of Honours-level mathematics subjects (numbered as 354xx). These consist of six four-credit-point subjects, at least five of which must be taken in the major area of study.
- A thesis consisting of a research project of 16 credit points, assessed by a written report and a seminar. A supervisor will be appointed to monitor the progress of the thesis and to advise on its preparation. Full-time students must enrol in the subject 35498 Thesis (Honours) in the first semester of their program. Part-time students must enrol in this subject at the beginning of their second year.
- Eight credit points consisting of the subjects 35496 Thesis Seminar A and 35497 Thesis Seminar B. These are reading courses designed to complement the research project or to provide additional foundation for graduate study in the area of the project. The thesis supervisor will be responsible for designing and administering these subjects. In certain circumstances, these subjects may be replaced by Honours Seminar subjects.

Subjects offered in the various strands are as follows.

### Mathematics strand

35418	Analytic Number Theory	4cp
35419	Advanced Algebra	4cp
35427	Functional Analysis	4cp
35428	Convexity and Optimisation	4cp
35436	Advanced Mathematical Methods	4cp
35437	Partial Differential Equations	4cp
35438	Nonlinear Dynamical Systems	4cp
35466	Advanced Stochastic Processes	4cp

**Operations Research strand**

35443	Advanced Mathematical Programming	4cp
35446	Scheduling Theory	4cp
35447	Discrete Optimisation	4cp
35448	Dynamic Optimisation	4cp
35466	Advanced Stochastic Processes	4cp
35485	Advanced Financial Modelling	4cp
35486	Optimal Control 1	4cp
35487	Optimal Control 2	4cp

**Statistics strand**

35456	Nonlinear Statistical Models	4cp
35457	Multivariate Statistics	4cp
35458	Loglinear Modelling	4cp
35459	Linear Models and Experimental Design	4cp
35466	Advanced Stochastic Processes	4cp
35467	Time Series Analysis	4cp
35469	Statistical Consulting	4cp

Each strand is augmented by two seminar subjects, 35491 Honours Seminar A and 35492 Honours Seminar B. These Seminar subjects will be offered either by a visitor to the School, or by members of the School's staff in some particular area of interest at the time.

These strands may be amended as areas of significance and interest in the School change with time.

**Grading of awards**

Students' final results will be based on the coursework subjects, the thesis and the associated seminar. Satisfactory completion of the Honours program will result in the award of an Honours degree with the grade of First Class, Second Class (Division 1), Second Class (Division 2) or Third Class.

The grade of Honours will be determined from the average mark of all subjects, weighted by their credit point values. The grade of First Class, Second Class (Division 1), Second Class (Division 2) or Third Class Honours will be awarded for an average mark in the range of 80–100, 70–79, 60–69 or 50–59, respectively. An average mark of less than 50 will be regarded as a failure. A thesis that is of outstanding merit may justify an increase in the grade of Honours. A student with First Class Honours and outstanding results may be awarded a University Medal.

**Bachelor of Science in Mathematics/Bachelor of Arts in International Studies****Course code: MM05**

This course combines the Bachelor of Science in Mathematics with the University's Bachelor of Arts in International Studies. Mathematics is integrated with a major in the language and culture of another country. Students spend the fourth year of study at a university overseas. Owing to timetabling constraints, the combined degree is only offered on a full-time basis over five years.

**Studies in Mathematical Sciences**

The Mathematical Sciences component of the combined degree aims to provide students with a broad education in the field, to prepare graduates for professional practice in industry, commerce and government, and to provide the foundation for graduate studies and research. It provides great flexibility by allowing students to follow a course of study that best suits their interests and aspirations. It aims to help the students acquire sufficient experience and understanding in a broad range of mathematical disciplines to enable them to apply mathematical and computing techniques to industrial and commercial problems.

For further information, see the course outline for the Bachelor of Science in Mathematics in this handbook.

An Honours degree in Mathematics (with strands in Statistics, Operations Research and Mathematics), requiring an additional year of full-time study, is also available.

**International Studies**

The Bachelor of Arts in International Studies is designed to increase awareness and understanding of the non-English-speaking world.

Students take one of the following majors in the International Studies program: China, Eastern Europe, Indonesia, Japan, Latin America, Malaysia, South China, South-East Asia, Spain, Taiwan, Thailand or Western Europe. They study an appropriate language and culture; learn about the contemporary society of their country of specialisation; and

then spend an academic year of study at a university in their country of specialisation. The costs of tuition and travel are borne by UTS. In many cases, there will be no additional costs for students. However, those studying in countries or regions where the cost of living is high – notably Japan, Argentina, Hong Kong and Taiwan – should be prepared to pay additional costs for accommodation and maintenance.

### Course structure

The structure of the five-year course in Mathematical Sciences and International Studies is derived from the combination of the Bachelor of Science in Mathematics with the Bachelor of Arts in International Studies.

All arrangements currently in force for both the Bachelor of Science in Mathematics and the Bachelor of Arts in International Studies apply equally to the combined degree program in Mathematical Sciences and International Studies.

To graduate a student is required to have completed 240 credit points: 144 credit points in Mathematics and 96 credit points in International Studies.

The Mathematics component of the combined degree is structured in three distinct sections: core studies, a major in an area of the mathematical sciences, and an elective component, precisely as for the Bachelor of Science in Mathematics. The major is taken in the final (fifth) year of study.

The Bachelor of Arts in International Studies requires undergraduates to study a major – a region or country of specialisation – over a minimum of three years. Students study language and culture for at least two years in Sydney, and this is followed by a period of study overseas. The following majors are offered: Argentina, Australia and the Asia-Pacific Region, Chile, China, Croatia, France, Germany, Greece, Indonesia, Italy, Japan, Latin America, Malaysia, Mexico, Poland, Russia, Slovenia, South China, South-East Asia, Spain, Taiwan, Thailand and Ukraine. Details of the International Studies subjects are available in the *Institute for International Studies Handbook*.

Each of the specialisations within the International Studies program is 96 credit points, and includes 32 credit points (four subjects) of instruction in an appropriate Language and Culture; 16 credit points (two subjects) of the study of Contemporary Society and its context; and 48 credit points (two

semesters) of study at a university or institution of higher education in the country or region of specialisation.

The International Studies subjects listed in the course program are subjects of enrolment referring to common units of instruction across the University.

### Language and Culture

Study of Language and Culture at UTS depends on the individual student's level of language proficiency before entry to the UTS program. There is a range of entry levels to the various Language and Culture programs available. Most are available at beginner's and post-HSC levels, and some at more advanced levels.

The Institute for International Studies offers Language and Culture programs in Cantonese, Chinese, Indonesian, Japanese, Malaysian and Spanish on UTS campuses through arrangements with the Insearch Language Centre. Higher levels of these languages may be offered through arrangements with other universities in the Sydney area.

Croatian, French, German, Greek, Italian, Korean, Polish, Russian, Slovenian, Thai and Ukrainian are offered to UTS students through arrangements that have been made with other Sydney universities.

### Contemporary Society

For each specialisation of the International Studies program, students have a prescribed pair of units of instruction in Contemporary Society, taught by the Institute for International Studies in cooperation with the Faculty of Humanities and Social Sciences.

The first is a subject on Modernisation and Social Change that provides a general introduction to comparative social and political change. It is designed to locate further study of the major in its intellectual and physical contexts.

The second is a subject that provides a more detailed introduction to the area of specialisation, and which is specific for each major:

- China: *Contemporary China*
- Eastern Europe: *Contemporary Europe*
- Indonesia: *Contemporary South-East Asia*
- Japan: *Contemporary Japan*
- Latin America: *Contemporary Latin America*
- Malaysia: *Contemporary South-East Asia*

- South China: *Chinese East Asia*
- South-East Asia: *Contemporary South-East Asia*
- Spain: *Contemporary Europe*
- Taiwan: *Chinese East Asia*
- Thailand: *Contemporary South-East Asia*
- Western Europe: *Contemporary Europe*

**In-country Study**

Arrangements for students to spend two semesters of study at an institution of higher education in the country or region of specialisation have already been made, or are in train. The first semester will largely be concerned with further language development and cultural appreciation. The second semester will continue the study of language and culture but, where possible, will attempt to direct study towards subjects related to the mathematical sciences. Where students have reached an appropriate level of language competence, arrangements may be made to substitute one or two semesters of industrial experience for periods of In-country Study. In-country industrial experience undertaken in this way will be assessed by UTS in a manner similar to subjects of In-country Study, though through cooperation between the Institute for International Studies and the School of Mathematical Sciences.

**Course program**

**Year 1**

---

**Autumn semester**

35100	Mathematical Practice	3cp
35101	Mathematics 1	6cp
35111	Discrete Mathematics	3cp
35170	Introduction to Computing	6cp
	Electives	6cp

**Spring semester**

35102	Mathematics 2	6cp
35151	Statistics 1	6cp
	Electives	6cp
	Electives	6cp

**Year 2**

---

**Autumn semester**

35212	Linear Algebra	6cp
35232	Advanced Calculus	6cp
971xxx	Language and Culture 1	8cp

**Spring semester**

35241	Optimisation 1	6cp
35252	Statistics 2	6cp
35281	Numerical Analysis 1	6cp
972xxx	Language and Culture 2	8cp

**Year 3**

---

**Autumn semester**

35231	Differential Equations	6cp
50140	Modernisation and Social Change	8cp
973xxx	Language and Culture 3	8cp
	Electives	6cp

**Spring semester**

35321	Analysis 1	6cp
974xxx	Language and Culture 4	8cp
976xxx	Contemporary Society	8cp

**Year 4**

---

**Autumn semester**

977xxx	In-country Study 1	24cp
--------	--------------------	------

**Spring semester**

978xxx	In-country Study 2	24cp
--------	--------------------	------

**Year 5**

---

**Autumn semester**

353xx	Mathematics Major 1	6cp
353xx	Mathematics Major 2	6cp
	Electives	6cp
	Electives	6cp

**Spring semester**

353xx	Mathematics Major 3	6cp
353xx	Mathematics Major 4	6cp
	Electives	6cp
	Electives	6cp

**Note:** Students intending to complete the elective major in Computing will need to interchange Analysis 1 with an Elective from Year 5 Autumn semester.

**Majors**

The program for each of the majors corresponds precisely with that in the Bachelor of Science in Mathematics.

## Arrangements for In-country Study

In general, students may expect that no additional costs will be incurred through following a period of In-country Study as part of this degree program. The two semesters of In-country Study are full-credit subjects at UTS for which HECS is payable. There are, however, no further tuition fees and the Institute for International Studies will provide travel subsidies. Students in receipt of Austudy in Australia are also able to receive it while they are engaged in In-country Study.

Some of the countries targeted in the International Studies program are relatively 'high-cost'. Though the Institute for International Studies will assist students enrolled in a period of In-country Study in one of those countries with their costs, it cannot guarantee to meet all additional costs. In such cases, students need to be prepared to shoulder a proportion of the costs themselves. Japan is the most obvious case in point.

Under normal circumstances, students can only proceed to a period of In-country Study within the International Studies program if they have successfully completed all earlier stages in the degree program. Students who have not successfully completed all earlier stages may only proceed to a period of In-country Study under exceptional circumstances and with the permission of both the Dean of the Faculty and the Director of the Institute for International Studies.

Before students leave UTS to engage in a period of In-country Study within the International Studies program, they may be required to meet appropriate financial and enrolment requirements by the Director of the Institute for International Studies. They will also be required to agree to be governed by the Institute's code of good conduct during their period of In-country Study.

## Bachelor of Mathematics and Finance

### Course code: MM03

The years since deregulation of the Australian financial system have witnessed many sweeping changes and a considerable increase in the financial and economic activity of many Australian corporations. During this same period there has been an increasing use by major financial institutions of the sophisticated quantitative techniques that have been developed since the early 1970s. As a consequence, there is a demand for a new type of graduate trained in both mathematics and finance.

To meet this need, the Bachelor of Mathematics and Finance degree is offered jointly by the School of Mathematical Sciences and the School of Finance and Economics.

Students graduating from the BMathFin will have undertaken an integrated sequence of subjects in mathematics, statistics, finance, economics, accounting, business law and computing, and will therefore have sound training in both the traditional theory of finance and the mathematical aspects of modern portfolio management techniques.

As a result, graduates should find interesting and rewarding employment in major financial institutions such as merchant banks, insurance companies and government instrumentalities.

The Bachelor of Mathematics and Finance is offered as a three-year Pass degree with a fourth year Honours degree.

The Pass degree is offered on both a full-time and a part-time basis. In the first four years of the course, part-time students will be expected to be able to attend classes on one afternoon and two or three evenings per week. The final two years may require attendance at morning classes because some subjects, which form parts of other degrees, are not offered at night. Programs will be arranged individually for part-time students to spread the eight subjects of Year 3 of the full-time course over two years.

### Grading of awards

The School of Mathematical Sciences does not grade students eligible to receive the Bachelor of Mathematics and Finance degree.



**Course program****Full-time program****Year 1****Autumn semester**

22105	Accounting A	4cp
25110	Microeconomics	4cp
25308	Financial Markets	4cp
35101	Mathematics 1	6cp
35170	Introduction to Computing	6cp

**Spring semester**

25209	Macroeconomics	4cp
25314	Business Finance	4cp
35100	Mathematical Practice	3cp
35102	Mathematics 2	6cp
35151	Statistics 1	6cp

**Year 2****Autumn semester**

35111	Discrete Mathematics	3cp
35212	Linear Algebra	6cp
35231	Differential Equations	6cp
35232	Advanced Calculus	6cp
79202	Business Law	4cp

**Spring semester**

25905	Capital Budgeting and Valuation (Honours)	6cp
25906	Investment Analysis (Honours)	6cp
35252	Statistics 2	6cp
35281	Numerical Analysis 1	6cp

**Year 3****Autumn semester**

25621	Financing Decisions and Capital Market Theory	6cp
25620	Derivative Securities	6cp
	<i>or</i>	
25210	Microeconomic Theory and Policy	6cp
35321	Analysis 1	6cp
35361	Probability and Stochastic Processes	6cp

**Spring semester**

25421	International Financial Management	6cp
25606	Financial Time Series Analysis	6cp
35241	Optimisation 1	6cp
	<i>or</i>	
35322	Analysis 2	6cp
35353	Regression Analysis	6cp

Students not intending to proceed to Honours must take the subjects 25620 Derivative Securities and 35241 Optimisation 1 in their Year 3 program. Students intending to undertake the Honours degree must include 25210 Microeconomic Theory and Policy and 35322 Analysis 2 in their Year 3 program.

**Part-time program****Year 1****Autumn semester**

22105	Accounting A	4cp
35100	Mathematical Practice	3cp
35101	Mathematics 1	6cp

**Spring semester**

25110	Microeconomics	4cp
35170	Introduction to Computing	6cp

**Year 2****Autumn semester**

25209	Macroeconomics	4cp
35102	Mathematics 2	6cp
35111	Discrete Mathematics	3cp

**Spring semester**

25308	Financial Markets	4cp
25314	Business Finance	4cp
35212	Linear Algebra	6cp

**Year 3****Autumn semester**

35151	Statistics 1	6cp
79202	Business Law	4cp

**Spring semester**

35231	Differential Equations	6cp
35232	Advanced Calculus	6cp

**Year 4****Autumn semester**

35252	Statistics 2	6cp
35281	Numerical Analysis 1	6cp

**Spring semester**

25905	Capital Budgeting and Valuation (Honours)	6cp
25906	Investment Analysis (Honours)	6cp

**Year 5****Autumn semester**

25621	Financing Decisions and Capital Market Theory	6cp
35353	Regression Analysis	6cp

**Spring semester**

25606	Financial Time Series Analysis	6cp
35321	Analysis 1	6cp

**Year 6****Autumn semester**

25620	Derivative Securities	6cp
	<i>or</i>	
25210	Microeconomic Theory and Policy	6cp
35361	Probability and Stochastic Processes	6cp

**Spring semester**

25421	International Financial Management	6cp
35241	Optimisation 1	6cp
	<i>or</i>	
35322	Analysis 2	6cp

Students not intending to proceed to Honours must take the subjects 25620 Derivative Securities and 35241 Optimisation 1 in their Year 6 program. Students intending to undertake the Honours degree must include 25210 Microeconomic Theory and Policy and 35322 Analysis 2 in their Year 6 program.

**Bachelor of Mathematics and Finance (Honours)**

**Course code: MM04**

The Bachelor of Mathematics and Finance degree is also offered at an Honours level, requiring an additional year of advanced study. Honours degree graduates will be particularly sought after and their additional skills will enable them to compete for high-entry-level jobs in the banking sector. It is expected that most students will opt to undertake this additional year.

Admission to the Honours degree will be assessed individually according to the following criteria:

- Students who are eligible to graduate from the BMathFin degree at UTS with an average mark of 65 or more over all subjects in Years 2 and 3 (full-time) will be eligible for entry to the Honours degree, subject only to the approval of the Heads of the Schools of Mathematical Sciences and Finance and Economics.
- Students who have obtained qualifications equivalent to the BMathFin degree will be considered for entry, upon application, by the Heads of the two participating Schools on the basis of their assessed potential to complete the Honours degree.

The Honours degree will require completion of subjects worth 48 credit points over one year of full-time study. The year consists of nine coursework subjects of an advanced nature in mathematics, statistics and finance, together with a substantial project. The project will involve a major investigation over two semesters of some area of finance, and will provide students with the opportunity to apply the skills developed in their coursework.

The project will be assessed on the basis of a thesis and a seminar presented to the staff of both Schools.

**Grading of awards**

The assessment of students' results will take into account the Honours level coursework subjects, the thesis and the seminar. Honours at the grades of First Class, Second Class (Division 1), Second Class (Division 2) and Third Class will be awarded for the successful completion of the course.

**Course program**

Listed below is the course program for the BMathFin(Hons) degree.

**Year 4**

**Autumn semester**

25907	Theory of Financial Decision Making	4cp
25910	Thesis	12cp
35438	Nonlinear Dynamical Systems	4cp
35466	Advanced Stochastic Processes	4cp
35467	Time Series Analysis	4cp
35486	Optimal Control 1	4cp

**Spring semester**

25908	Derivative Security Pricing	4cp
25909	Advanced Corporate Finance	4cp
25910	Thesis (cont.)	
35456	Nonlinear Statistical Models	4cp
35487	Optimal Control 2	4cp

## Bachelor of Mathematics and Finance/Bachelor of Arts in International Studies

**Course code:** MM06

This course combines the Bachelor of Mathematics and Finance with the University's Bachelor of Arts in International Studies. Studies in mathematics and finance are integrated with a major in the language and culture of another country. Students spend the fourth year of study at a university overseas. Because of timetabling constraints, the combined degree is available only on a full-time basis over five years.

### Studies in Mathematics and Finance

Students graduating from this degree will have undertaken an integrated sequence of study in mathematics, statistics, finance, economics, accounting, business law and computing, and thus will have sound training in both the traditional theory of finance and the mathematical aspects of modern portfolio management techniques. With such skills, graduates should find interesting and rewarding employment in major financial institutions including banks, insurance companies and government instrumentalities.

For further information, see the course outline for the Bachelor of Mathematics and Finance in this handbook.

The Mathematics and Finance components of the course occupy three effective full-time years. An Honours degree, leading to the qualification of BMathFin(Hons) and requiring an additional year of full-time study, is also available.

### International Studies

The Bachelor of Arts in International Studies is designed to increase awareness and understanding of the non-English-speaking world.

Students take one of the following majors in the International Studies program: China, Eastern Europe, Indonesia, Japan, Latin America, Malaysia, South China, South-East Asia, Spain, Taiwan, Thailand or Western Europe. They study an appropriate language and culture; learn about the contemporary society of their country of specialisation; and

then spend an academic year of study at a university in their country of specialisation. The costs of tuition and travel are borne by UTS. In many cases, there will be no additional costs for students. However, those studying in countries or regions where the cost of living is high – notably Japan, Argentina, Hong Kong and Taiwan – should be prepared to pay additional costs for accommodation and maintenance.

### Course structure

The structure of the five-year course in Mathematics and Finance and International Studies is derived from the combination of the Bachelor of Mathematics and Finance with the Bachelor of Arts in International Studies.

All arrangements in force for both the Bachelor of Mathematics and Finance and the Bachelor of Arts in International Studies apply equally to the combined degree program in Mathematics and Finance and International Studies.

To graduate a student is required to have completed 240 credit points: 144 credit points in Mathematics and Finance and 96 credit points in International Studies.

The Mathematics and Finance components of the course include an integrated sequence of subjects in mathematics, statistics, finance, economics, accounting, business law and computing.

The Bachelor of Arts in International Studies requires undergraduates to study a major – a region or country of specialisation – over a minimum of three years. Students study language and culture for at least two years in Sydney, and this is followed by a period of study overseas. The following range of majors are available: Argentina, Australia and the Asia-Pacific Region, Chile, China, Croatia, France, Germany, Greece, Indonesia, Italy, Japan, Latin America, Malaysia, Mexico, Poland, Russia, Slovenia, South China, South-East Asia, Spain, Taiwan, Thailand and Ukraine.

Each of the specialisations within the International Studies program is 96 credit points, and includes 32 credit points (four subjects) of instruction in an appropriate Language and Culture; 16 credit points (two subjects) of the study of Contemporary Society and its context; and 48 credit points (two semesters) of study at a university or institution of higher education in the country or region of specialisation.

The International Studies subjects listed in the course program are subjects of enrolment referring to common units of instruction across the University.

### Language and Culture

Study of Language and Culture at UTS depends on the individual student's level of language proficiency before entry to the UTS program. There is a range of entry levels to the various Language and Culture programs available. Most are available at beginner's and post-HSC levels, and some at more advanced levels.

The following Language and Culture programs are available at UTS as part of the International Studies program: Cantonese, Chinese, Indonesian, Japanese, Malay and Spanish. In addition, arrangements have been made for the delivery of Croatian, French, German, Greek, Italian, Polish, Russian, Slovenian, Ukrainian and Thai.

### Contemporary Society

For each specialisation of the International Studies program, students have a prescribed pair of units of instruction in Contemporary Society, taught by the Institute for International Studies in cooperation with the Faculty of Humanities and Social Sciences.

The first is a subject on Modernisation and Social Change that provides a general introduction to comparative social and political change. It is designed to locate further study of the major in its intellectual and physical contexts.

The second is a subject that provides a more detailed introduction to the area of specialisation, and which is specific for each major:

- Argentina: *Contemporary Latin America*
- Chile: *Contemporary Latin America*
- China: *Contemporary China*
- Croatia: *Contemporary Europe*
- France: *Contemporary Europe*
- Germany: *Contemporary Europe*
- Greece: *Contemporary Europe*
- Indonesia: *Contemporary South-East Asia*
- Italy: *Contemporary Europe*
- Japan: *Contemporary Japan*
- Latin America: *Contemporary Latin America*
- Malaysia: *Contemporary South-East Asia*
- Mexico: *Contemporary Latin America*

- Poland: *Contemporary Europe*
- Russia: *Contemporary Europe*
- Slovenia: *Contemporary Europe*
- South China: *Chinese East Asia*
- South-East Asia: *Contemporary South-East Asia*
- Spain: *Contemporary Europe*
- Taiwan: *Chinese East Asia*
- Thailand: *Contemporary South-East Asia*
- Ukraine: *Contemporary Europe*

### In-country Study

Arrangements for students to spend two semesters of study at an institution of higher education in the country or region of specialisation have already been made, or are in train. The first semester will largely be concerned with further language development and cultural appreciation. The second semester will continue the study of language and culture but, where possible, will attempt to direct study towards subjects related to mathematics and finance. Where students have reached an appropriate level of language competence, arrangements may be made to substitute one or two semesters of industrial experience for periods of In-country Study. In-country industrial experience undertaken in this way will be assessed by UTS in a manner similar to subjects of In-country Study, though through cooperation between the Institute for International Studies and the School of Mathematical Sciences.

### Course program

#### Year 1

##### Autumn semester

22105	Accounting A	4cp
25110	Microeconomics	4cp
25308	Financial Markets	4cp
35101	Mathematics 1	6cp
35170	Introduction to Computing	6cp

##### Spring semester

25209	Macroeconomics	4cp
25314	Business Finance	4cp
35100	Mathematical Practice	3cp
35102	Mathematics 2	6cp
35151	Statistics 1	6cp

#### Year 2

##### Autumn semester

35111	Discrete Mathematics	3cp
35212	Linear Algebra	6cp

35231	Differential Equations	6cp
971xxx	Language and Culture 1	8cp

**Spring semester**

25905	Capital Budgeting and Valuation (Hons)	6cp
35252	Statistics 2	6cp
35281	Numerical Analysis	6cp
972xxx	Language and Culture 2	8cp

**Year 3****Autumn semester**

35232	Advanced Calculus	6cp
50140	Modernisation and Social Change	8cp
79202	Business Law	4cp
973xxx	Language and Culture 3	8cp

**Spring semester**

25906	Investment Analysis (Hons)	6cp
974xxx	Language and Culture 4	8cp
976xxx	Contemporary Society	8cp

**Year 4****Autumn semester**

977xxx	In-country Study 1	24cp
--------	--------------------	------

**Spring semester**

978xxx	In-country Study 2	24cp
--------	--------------------	------

**Year 5****Autumn semester**

25620	Derivative Securities	6cp
25621	Financing Decisions and Capital Market Theory	6cp
35321	Analysis 1	6cp
35361	Probability and Stochastic Processes	6cp

**Spring semester**

25421	International Financial Management	6cp
25606	Financial Time Series Analysis	6cp
35241	Optimisation 1	6cp
35353	Regression Analysis	6cp

**Note:** Students intending to proceed to the Honours degree in Mathematics and Finance should substitute 25210 Microeconomic Theory and Policy for the subject 25620 Derivative Securities and 35322 Analysis 2 for the subject 35241 Optimisation 1 in their final year.

**Arrangements for In-country Study**

The two semesters of In-country Study are full-credit subjects at UTS for which HECS is payable. There are, however, no further tuition fees and the Institute for International Studies will provide travel subsidies. Students in receipt of Austudy in Australia are also able to receive it while they are engaged in In-country Study.

In most cases the cost of living for the period of In-country Study will not exceed the cost of living away from home in Sydney. However, students should be aware that the cost of living in some countries – notably Argentina, France, Germany, Hong Kong, Japan and Taiwan – may be higher than in Sydney.

Under normal circumstances, students can only proceed to a period of In-country Study within the International Studies program if they have successfully completed all earlier stages in the degree program. Students who have not successfully completed all earlier stages may only proceed to a period of In-country Study under exceptional circumstances and with the permission of both the Dean of the Faculty and the Director of the Institute for International Studies.

Before students leave UTS to engage in a period of In-country Study within the International Studies program they may be required to meet appropriate financial and enrolment requirements by the Director of the Institute for International Studies. They will also be required to agree to be governed by the Institute's code of good conduct during their period of In-country Study.

# Postgraduate courses

---

## POSTGRADUATE RESEARCH DEGREES

The Master of Science (by thesis) (MSc) and Doctor of Philosophy (PhD) degrees provide the opportunity for graduates to extend and deepen their knowledge in specialised areas of mathematics by undertaking research under the supervision of a member of the academic staff.

The main interests within the School of Mathematical Sciences are in applied and computational mathematics, operations research and statistics. Particular interests and specialisations exist in the following areas:

### Clinical Trials and the Modelling of Medical Data

Inversion of Raman spectra of living cells; stability and uniqueness in compartmental models for medical applications; diabetic control; insulin sensitivity; and modelling of glucose and C-peptide response curves.

### Computational Mathematics and Computing

Lattice rules for numerical multiple integration; development of AMPL (A Mathematical Programming Language); database management system for diabetes; computer performance modelling; mathematical foundations of computing; and computer-aided instruction in mathematics.

### Differential Geometry

Topology and Ricci curvature; and integral formulas on submanifolds of a Riemannian manifold.

### Geophysical Applications of Mathematics

Seismic ray theory for slightly heterogeneous structures; properties of normal rays; seismic wave propagation; seismic velocity inversion; inverse problems; and radio frequency propagation in coal seams.

### Mathematics Education

PhD education of industrial mathematicians; mathematical education of engineers; tertiary education in applied mathematics; and statistical education.

### Mathematical Finance

Financial mathematics; stochastic analysis; numerics of stochastic differential equations; and modelling in economics and finance.

### Number Theory

Recurring sequences; odd perfect numbers and related numbers; and arithmetical functions.

### Operations Research

Simulation techniques; scheduling; discrete optimisation; neural networks; and finance theory and modelling.

### Optics and Electromagnetic Diffraction Theory

Diffraction properties of one-dimensional and two-dimensional periodic structures; and optics of thin films.

### Statistics

Medical applications of statistics; measurement and test design; permissible statistics; stationary Markov sequences; simulation and density estimation; and applied statistics.

Research projects that are focused on biomedical applications are conducted through the Centre for Biomedical Technology which was formed in 1990. The Centre is an interfaculty network of research and education teams working in the field of biomedical technology. It integrates the University's diverse expertise and resources to enhance the scientific and technological base for biomedical technology research and training for industry, health-care providers and government. Other schools and faculties involved with the Centre are the Faculty of Science, the Faculty of Nursing, the Faculty of Engineering and the School of Computing Sciences.

### Fees

Fees will be levied in accordance with University policies and DEETYA guidelines. Details will be available in early 1998.

## Recent theses

### PhD theses

Dobson, R J 1992, Modelling host regulation of trichostrongylus colubriformis, a nematode parasite of sheep.

Melham, R S 1995, Some aspects of homogeneous linear recursive sequences of order mainly two.

Wong, C-K 1996, Mathematical modelling of peptide kinetics in diabetes mellitus.

### MSc theses

Haggar, F 1991, An account of the behaviour of some pairs of  $e(1)$  variables.

Lee, J K 1991, Strategies for inversions for some geophysical and medical applications.

Thornton, F 1996, Combining diagnostic modalities to aid breast screening effectiveness.

Wood, J W 1997, Research and development and sensitivity analysis within the input-output model.

## Doctor of Philosophy

### Course code: MM54

---

The Doctor of Philosophy (PhD) program provides an opportunity for graduates to acquire high-level research skills and substantially deepen their knowledge in an area of the mathematical sciences by working under the guidance of a supervisor. The research program entails survey and mastery of a large body of literature in the chosen topic together with a substantial body of high-level original work by the candidate. Students are also required to present seminars during the time of their enrolment and at the completion of their program.

The course is offered in full-time and part-time modes. For full-time enrolments, the normal duration of the program is three years; for part-time enrolments, it is six years. It is expected that part-time students will be able to devote 20 hours per week to work towards the degree. All students are expected to maintain regular contact (at least weekly) with their supervisor.

## Master of Science

### Course code: MM51

---

The Master of Science (MSc) program provides an opportunity for graduates to acquire research skills and deepen their knowledge in some areas of the mathematical sciences. Students work under the guidance of a supervisor who is a member of the full-time academic staff of the School. The research program entails survey and mastery of a substantial body of literature in the chosen topic together with original work from the candidate. The degree is examined through the presentation of a thesis. Students are also required to present seminars during the time of their enrolment and at the completion of their program.

The course is offered in full-time and part-time modes. For full-time enrolments, the normal duration of the program is two years; for part-time enrolments, it is four years. It is expected that part-time students will be able to devote 20 hours per week to work towards the degree. All students are expected to maintain regular contact (at least weekly) with their supervisor.

## POSTGRADUATE COURSEWORK PROGRAMS

### Master of Science in Operations Research

**Course code: MM53**

Operations research is known also as management science. It may be defined as the application of the methods of science to complex problems arising in the direction and management of large systems of people, materials and money in industry, business, government and defence. Problems typically dealt with include production scheduling, logistics, transportation planning, aircrew scheduling, inventory control, health management, environmental management, and financial applications.

This course aims to prepare graduates for high-level professional work in the application of management science to the problems of modern society. The subjects in the program provide students with a suite of advanced techniques in such areas as optimisation, mathematical programming and simulation, together with skills for their effective utilisation in the workplace. A broad spectrum of case studies is used to support and strengthen the student's appreciation, understanding and application of operations research to high-level professional work in industries dealing with production, service, health, and all areas of business and finance.

Applicants for the course must be graduates who have completed studies in operations research or management science corresponding to the Graduate Diploma in Operations Research, or the Operations Research major of the BSc in Mathematics, or an equivalent course. The course has a requirement of two years germane work experience. Applicants not satisfying the academic prerequisites are advised to consider enrolling in the Graduate Diploma in Operations Research or the Graduate Certificate programs offered by the School. All applicants should discuss their eligibility for entry with the Director, Postgraduate Studies, and must complete an application form which includes a description of prior work experience.

#### Fees

There are no government-funded student places for this course and it is necessary to charge full fees. The cost of the course has been set at \$4,080 for local students and \$6,000 for international students for each semester of equivalent full-time study. Fees for part-time students are levied on a pro rata basis. Some scholarships may be available for local students in financial need. For further information, please contact the Faculty Office. Course fees are revised from year to year in accordance with University and government policy.

#### Course structure

The course has a length of 48 credit points and consists of two core subjects (each six credit points), twelve credit points of elective subjects, and a substantial project of 24 credit points. It is offered full-time over two semesters or part-time over four semesters. Part-time students should be aware that some daytime attendance may be unavoidable.

Depending on demand, electives may be developed and offered within the School of Mathematical Sciences in such areas as quantitative business management, neural networks, cybernetics, large scale optimisation, and scheduling, with varying mathematical prerequisites. The subjects in the Bachelor of Science (Honours) in Mathematics are available as well for this purpose, for suitably qualified students. Electives may also be chosen from the Faculty of Business. Applicants who must first undertake the Graduate Diploma in Operations Research may be able to combine elective choices from both courses to form a useful sequence of three or four subjects.

The project is the main component of the subject 35599 Report, extending over two semesters. Studies for the project will normally be related to the applicant's prior work experience. An oral presentation in the form of a seminar is also required.

Students will have their registration discontinued for failure to complete the course in three years from the time of registration in the case of a full-time student, or in four-and-a-half years in the case of a part-time student (not inclusive of periods of leave of absence) (Rule 3.3.7.1), or for recording any three failures in the course (unsatisfactory progress as defined by the Faculty Board resolution, FBMC/92/70) (Rule 3.3.7.2).



## Course program

**The course program consists of the following subjects:**

35545	Further Methods in Operations Research	6cp
35549	Case Studies in Management Science	6cp
35599	Report Electives	24cp 12cp

## Graduate Diploma in Applicable Mathematics

**Course code: MM67**

The Graduate Diploma in Applicable Mathematics is designed to offer suitably qualified graduates the background in mathematics required to pursue further studies in an area of mathematics, and particularly in the area of mathematical finance. Students will be expected to have a sound background in mathematics and statistics to approximately second-year level.

The subjects in the Graduate Diploma include the necessary undergraduate mathematics background that will enable its graduates to proceed into the Bachelor of Mathematics and Finance (Honours) degree, provided an acceptable standard is reached. Exemption from some subjects, due to prior study, will be available where warranted.

The length of the course is 48 credit points, comprising coursework in eight subjects. One of these subjects is an elective that would generally be chosen from one of the major areas (Mathematics, Statistics or Operations Research) in the Bachelor of Science in Mathematics degree. The course is offered full-time over two semesters or part-time over four semesters. Part-time students should be aware that attendance at day-time classes for some subjects may be unavoidable.

Applicants for the Graduate Diploma should discuss their eligibility with the Director, Postgraduate Studies. Those who have not completed the necessary prerequisites will be required to enrol in appropriate subjects, either as miscellaneous students or in a Graduate Certificate program.

Students will have their registration discontinued for failure to complete the course in eight semesters from the time of registration in the case of a part-time student, or four semesters from that time in the case of a full-time student, not inclusive of periods of leave

of absence (Rule 3.2.6.1), or for any three failures in the course (unsatisfactory progress as defined by the Faculty Board resolution, FBMC/94/80) (Rule 3.2.6.2).

## Fees

There are no government-funded student places for this course and it is necessary to charge full fees. The cost of the course has been set at \$3,600 for local students and \$5,500 for international students for each semester of equivalent full-time study. Fees for part-time students are levied on a pro rata basis. Some scholarships may be available for local students in financial need. For further information, please contact the Faculty Office. Course fees are revised from year to year in accordance with University and government policy.

## Course program

**The course program consists of the following subjects:**

35231	Differential Equations	6cp
35252	Statistics 2	6cp
35232	Advanced Calculus	6cp
35321	Analysis 1	6cp
35353	Regression Analysis	6cp
35322	Analysis 2	6cp
35361	Probability and Stochastic Processes	6cp
	Elective	6cp

## Graduate Diploma in Mathematics and Finance

**Course code: MM66**

The Graduate Diploma in Mathematics and Finance is designed to allow suitable graduates in one area of mathematics, say statistics or pure mathematics, to be retrained so that they will have sufficient knowledge of relevant aspects of financial modelling to enable them to participate authoritatively in the area of finance. Students will be expected to have a sound background in mathematics and statistics to first-year level.

The subjects in the Graduate Diploma range from necessary background material at undergraduate level through to Honours level subjects in time-series analysis and financial modelling. Exemptions from subjects, due to prior study, will be available where warranted.

The length of the course is 48 credit points, comprising coursework in eight subjects, one

of which is an elective subject. The course is offered full-time over three semesters or part-time over four semesters. Part-time students should be aware that attendance at daytime classes for some subjects may be unavoidable.

Applicants for the Graduate Diploma should discuss their eligibility with the Director, Postgraduate Studies. Those who have not completed the necessary prerequisites will be required to enrol in appropriate subjects, either as miscellaneous students or in a Graduate Certificate program.

Students will have their registration discontinued for failure to complete the course in eight semesters from the time of registration in the case of a part-time student, or four semesters from that time in the case of a full-time student, not inclusive of periods of leave of absence (Rule 3.2.6.1), or for any three failures in the course (unsatisfactory progress as defined by the Faculty Board resolution, FBMC/94/80) (Rule 3.2.6.2).

## Fees

There are no government-funded student places for this course and it is necessary to charge full fees. The cost of the course has been set at \$3,600 for local students and \$5,500 for international students for each semester of equivalent full-time study. Fees for part-time students are levied on a pro rata basis. Some scholarships may be available for local students in financial need. For further information, please contact the Faculty Office. Course fees are revised from year to year in accordance with University and government policy.

## Course program

**The course program consists of the following subjects:**

33401	Introductory Mathematical Methods	6cp
35252	Statistics 2	6cp
35361	Probability and Stochastic Processes	6cp
35384	Financial Modelling	6cp
35241	Optimisation 1	6cp
35353	Regression Analysis	6cp
35467	Time Series Analysis	4cp
35485	Advanced Financial Modelling	4cp
	Elective	4cp

## Graduate Diploma in Operations Research

**Course code: MM52**

This course is designed to train professional people in the application of operations research principles and methods. It may be regarded as a training or retraining course for graduates from a wide range of disciplines, provided they have a sound foundation in mathematics, statistics and computing to approximately first-year level. It is ideally suited for subsequent entry into the Master of Science in Operations Research, provided a suitable standard is attained and the work experience requirement is satisfied.

The subjects in the Graduate Diploma cover standard operations research techniques and their theoretical foundations. The range of topics and the level of presentation are commensurate with those found in senior undergraduate studies in this discipline.

The length of the course is 48 credit points, comprising coursework in eight subjects, two of which are elective subjects. These may be combined into a single 12cp project taken over two semesters. The course is offered full-time over two semesters or part-time over four semesters. For part-time students, attendance at daytime classes for some subjects may be unavoidable.

Applicants for the Graduate Diploma program should discuss their eligibility with the Director, Postgraduate Studies.

Students will have their registration discontinued for failure to complete the course in eight semesters from the time of registration in the case of a part-time student, or four semesters from that time in the case of a full-time student, not inclusive of periods of leave of absence (Rule 3.2.6.1), or for any three failures in the course (unsatisfactory progress as defined by the Faculty Board resolution, FBMC/94/80) (Rule 3.2.6.2).

## Fees

There are no government-funded student places for this course and it is necessary to charge full fees. The cost of the course has been set at \$3,600 for local students and \$5,500 for international students for each semester of equivalent full-time study. Fees for part-time students are levied on a pro rata basis. Some scholarships may be available for local students in financial need. For further

information, please contact the Faculty Office. Course fees are revised from year to year in accordance with University and government policy.

## Course program

**The course program consists of the following subjects:**

33401	Introductory Mathematical Methods	6cp
35241	Optimisation 1	6cp
35151	Statistics 1	6cp
35363	Simulation Modelling	6cp
35342	Optimisation 2	6cp
35340	Operations Research Practice	6cp
	Electives	12cp

## Graduate Diploma in Statistics

**Course code: MM65**

The Graduate Diploma in Statistics aims to train graduates in the methods and principles of applied statistics. The course provides access to training or retraining in statistics to at least the level of skill attained by students completing the BSc in Mathematics degree with the Statistics major. Students will be expected to have some statistical and mathematical background.

A knowledge of statistical methodology is becoming ever more important for graduates in many disciplines. Degree courses in the sciences, in engineering and in business often do not provide the exposure to statistics which graduates find they need in employment. This course is suitable for such graduates and also for those who have completed degrees in pure or applied mathematics without a major in statistics.

The subjects in the Graduate Diploma cover standard statistical techniques and their theoretical foundations. The range of topics and the level of presentation are commensurate with those found in senior undergraduate studies in this discipline.

The length of the course is 48 credit points, comprising coursework in eight subjects, three of which are elective subjects. Two of these elective subjects may be combined into a single 12cp project extending over two semesters. It is also possible to choose Honours level subjects as electives depending on satisfaction of prerequisites at a suitable level.

The course is offered full-time over two semesters or part time over four semesters. Part-time students should be aware that attendance at daytime classes for some subjects may be unavoidable.

Applicants for this course will be graduates from a variety of disciplines who satisfy the basic entry requirements. These consist of a knowledge of statistics and pure and applied mathematics equivalent to the subjects 35252 Statistics 2 and 35102 Mathematics 2. Prospective applicants will be assessed by the Director, Postgraduate Studies, and those who have not completed the necessary prerequisites will be required to enrol in appropriate subjects, either as miscellaneous students or as part of a Graduate Certificate program.

Students will have their registration discontinued for failure to complete the course in eight semesters from the time of registration in the case of a part-time student, or four semesters from that time in the case of a full-time student, not inclusive of periods of leave of absence (Rule 3.2.6.1), or for any three failures in the course (unsatisfactory progress as defined by the Faculty Board resolution, FBMC/94/80) (Rule 3.2.6.2).

## Fees

There are no government-funded student places for this course and it is necessary to charge full fees. The cost of the course has been set at \$3,600 for local students and \$5,500 for international students for each semester of equivalent full-time study. Fees for part-time students are levied on a pro rata basis. Some scholarships may be available for local students in financial need. For further information, please contact the Faculty Office. Course fees are revised from year to year in accordance with University and government policy.

## Course program

**The course program consists of the following subjects:**

35170	Introduction to Computing	6cp
35353	Regression Analysis	6cp
35355	Quality Control	6cp
35356	Design and Analysis of Experiments	6cp
35361	Probability and Stochastic Processes	6cp
	Electives	18cp

## Graduate Certificate in Mathematical Sciences

### Course code: MM56

The Graduate Certificate in Mathematical Sciences has been developed in response to a demand for short courses in mathematics, statistics, operations research and computational mathematics. It provides those employed in industry with access to additional training or retraining in quantitative disciplines.

The course has a flexible structure and the wide range of subjects offered in the other postgraduate and undergraduate courses in the School of Mathematical Sciences is available to intending students. Students may undertake any sequence of subjects offered by the School with a total value of 12 credit points, provided that individual subject prerequisites are satisfied.

Applicants will normally be expected to hold a Bachelor's degree, or higher qualification, from a recognised tertiary institution. Applicants who do not possess such qualifications will be considered on an individual basis. Prior to their admission, all applicants will be required to discuss their preferred program of study with the Graduate Certificate Coordinator in order to ensure that they have the requisite background knowledge for their chosen subject sequences.

### Maximum time rule

Students will have their registration discontinued for failure to complete the course in three semesters from the time of registration in the case of a part-time student, or two semesters from that time in the case of a full-time student, not inclusive of periods of leave of absence (Rule 3.2.6.1).

### Fees

Full tuition fees will be charged for this course. In 1998 a fee of \$1,020 per subject will be payable. This fee is subject to annual review.

### Course program

A number of coherent subject sequences in the areas of mathematics, computational mathematics, operations research and statistics are possible. Samples of these are listed below. Some computing subjects require extra attendance for laboratory work. Details are given in the 'Subject descriptions' section for

the School of Mathematical Sciences in this handbook.

### Computational Mathematics

#### Sequence A

Theme: Numerical Analysis

##### *Presumed knowledge*

Equivalent to introductory courses in calculus, linear algebra and differential equations, and an elementary knowledge of the C language.

##### *Program of study*

35281	Numerical Analysis 1	6cp
35382	Numerical Analysis 2	6cp

#### Sequence B

Theme: Mathematical Cryptology

##### *Presumed knowledge*

Equivalent to an introductory course in linear algebra, and an intermediate-level knowledge of a modern procedural language.

##### *Program of study*

35314	Pure Mathematics 3B	6cp
35376	Advanced Topics in Computing A (Modules: Cryptology, High Performance Computing)	6cp

#### Sequence C

Theme: Neural Networks

##### *Presumed knowledge*

Equivalent to introductory courses in calculus, matrix algebra and statistics, and an intermediate-level knowledge of a modern procedural language.

##### *Program of study*

35232	Advanced Calculus	6cp
35376	Advanced Topics in Computing A (Modules: Neural Networks, High Performance Computing)	6cp

### Mathematics

#### Sequence A

Theme: Differential Equations

##### *Presumed knowledge*

Equivalent to introductory courses in calculus and linear algebra.

##### *Program of study*

35102	Mathematics 2	6cp
35231	Differential Equations	6cp

**Sequence B**

Theme: Modern and Linear Algebra

*Presumed knowledge*

Equivalent to introductory courses in matrix algebra and discrete mathematics.

*Program of study*

35212	Linear Algebra	6cp
35314	Pure Mathematics 3B	6cp

**Sequence C**

Theme: Analysis with Applications to Probability Theory

*Presumed knowledge*

Equivalent to introductory courses in calculus, differential equations and linear algebra.

*Program of study*

35321	Analysis 1	6cp
35322	Analysis 2	6cp

**Operations Research**

**Sequence A**

Theme: Financial Modelling

*Presumed knowledge*

Equivalent to intermediate courses in calculus, linear algebra and statistics.

*Program of study*

35241	Optimisation 1	6cp
35340	Operations Research Practice	6cp

**Sequence B**

Theme: Techniques of Mathematical Programming

*Presumed knowledge*

Equivalent to intermediate courses in calculus and linear algebra.

*Program of study*

35241	Optimisation 1	6cp
35342	Optimisation 2	6cp

**Sequence C**

Theme: Simulation and Decision Support

*Presumed knowledge*

Equivalent to intermediate courses in calculus and statistics.

*Program of study*

35361	Probability and Stochastic Processes	6cp
35363	Simulation Modelling	6cp

**Statistics**

**Sequence A**

Theme: Analysis of Experimental Data

*Presumed knowledge*

Equivalent to introductory courses in calculus and statistics.

*Program of study*

35252	Statistics 2	6cp
35353	Regression Analysis	6cp

**Sequence B**

Theme: Industrial Applications of Statistics

*Presumed knowledge*

Equivalent to intermediate courses in calculus and statistics.

*Program of study*

35355	Quality Control	6cp
35361	Probability and Stochastic Processes	6cp

**Sequence C**

Theme: Mathematical Statistics

*Presumed knowledge*

Equivalent to intermediate courses in calculus and statistics.

*Program of study*

35356	Design and Analysis of Experiments	6cp
35361	Probability and Stochastic Processes	6cp

# Subject descriptions

---

## Guide to subject descriptions

The subject descriptions shown below indicate the subject number and name, the number of credit points for the subject (e.g. 4cp), and the number of formal contact hours per week (e.g. 3hpw). Also shown are the prerequisites or corequisites, if any, and a brief outline of the content.

Prerequisites are subjects that must be completed before taking the subject to which they refer. Corequisites may be completed before or be taken concurrently with the subject to which they refer.

Subjects offered by the School of Mathematical Sciences are listed first, followed by those offered by other faculties. Subjects offered by the School of Computing Sciences can be found in that School's 'Subject descriptions' section later in this handbook.

## 33401

### Introductory Mathematical Methods

6cp; 3hpw

Matrices and determinants. Gaussian reduction. Solution of linear equations. Eigenvalues and eigenvectors. Vectors. Products of vectors. Equations of lines and planes. Complex numbers. Polar form and de Moivre's theorem. Linear independence of vectors. Rank of a matrix. Symmetric matrices. Quadratic forms. Geometric transformations in two and three dimensions. Functions of one and several variables. Partial derivatives. Maxima and minima. Taylor's theorem. Gradient and Hessian. Classification of critical points.

## 35100

### Mathematical Practice

3cp; 3hpw

Introduction to the art and practice of mathematics. Perspectives on communication and mathematical communication. History of mathematical communication. Reading, writing and speaking mathematics. Mathematics in context. Inductive and deductive reasoning and scientific method. Mathematical practice case studies: proof techniques, problem solving and modelling.

## 35101

### Mathematics I

6cp; 6hpw

Matrices and determinants; solution of linear equations; Gaussian reduction. Eigenvalues and eigenvectors. Vectors: products of vectors, equations of lines and planes. Complex numbers: polar form, de Moivre's theorem. Limits, continuity and differentiation. Mean value theorem. Curve sketching. Related rates. Maxima and minima. Integration. Riemann sums; fundamental theorem of calculus; application to areas and volumes and to lengths of curves. Logarithm and exponential functions. Trigonometric and hyperbolic functions; inverse trigonometric and hyperbolic functions. L'Hôpital's rule.

## 35102

### Mathematics 2

6cp; 6hpw; prerequisite: 35101 Mathematics I

Methods of integration; improper integrals. Ordinary differential equations; first-order linear and variable separate equations; higher-order linear equations; undetermined coefficients. Sequences and series; tests for convergence; power series; radius of convergence; Taylor's series. Application of matrix exponentials to systems of linear differential equations. Series solution of linear differential equations; ordinary and regular singular points; Bessel functions. Partial derivatives, directional derivative and gradient; maxima and minima; Lagrange multipliers.

## 35106

### Mathematics in Sport

6cp; 6hpw for 6 weeks (Summer session)

Selection of major topics from: the assignment problem and its use for team selection, graphical statistics for performance prediction, graph theory and tournament construction, ranking methods, the mathematics of balls in flight. Instances of the use of mathematics in (alphabetically) athletics, basketball, blackjack, cricket, darts, football, snooker, tennis, among others.

**35111****Discrete Mathematics***3cp; 3hpw*

Graphs, paths, trees. Set operations. Indexing and recurrence relations. Propositional and predicate calculus. Groups and monoids. Automata. Permutations, combinations, partitions, counting and allocation problems.

**35151****Statistics I***6cp; 6hpw*

Describing and exploring data. Producing data. Probability. Random variables. Introduction to inference. Inference for distributions. Inference for categorical data. Regression. Analysis of variance. Distribution-free inference.

**35170****Introduction to Computing***6cp; 7hpw*

An introduction to computer systems by providing skills in the use of editors, user interfaces and operating systems. Three approaches to simple numerical and business problems will be developed: imperative programming, functional programming and the utilisation of spread-sheets, illustrating the complementary nature of these approaches to computing.

**35171****Computing I**

*6cp; 7hpw; prerequisite: 35170 Introduction to Computing; corequisite: 35111 Discrete Mathematics*

Further investigation of functional and imperative programming techniques. Functional programming: polymorphism, higher-order functions, finite and infinite lists, proofs of relations. Imperative programming: pointers, linked lists, arrays, static and dynamic variables, file handling. Searching and sorting algorithms. Lists, stacks, queues and trees. Design techniques: modularisation, abstraction, generalisation, structural induction, testing, information hiding. Comparison of functional and imperative programming paradigms with respect to iteration and recursion, eager and lazy evaluation, and the use of prototypes.

**35205****History of Mathematics***6cp; 4hpw*

Overview of general history. Overview of the history of mathematics. Mathematics before the Greeks. Greek mathematics and the development of logical argument and rigour. The decline of Greek mathematics. Indian and Arabic contributions to notation and calculation, and the preservation of Greek knowledge. Scholastic and Renaissance mathematics: the rediscovery of classical knowledge in Western Europe. The scientific revolution and the discovery of the calculus. Development of the calculus and its applications in continental Europe. The search for a rigorous foundation for the calculus and the rise of analysis. The resurgence of geometry and algebra in the 19th century.

**35212****Linear Algebra***6cp; 4hpw; prerequisite: 35101 Mathematics I*

Systems of linear equations, decompositions. Vector spaces. Inner product spaces, Gram-Schmidt orthogonalisation. The eigenvalue problem. Symmetric matrices, diagonalisation, quadratic forms. Jordan form. Matrix exponentials.

**35231****Differential Equations***6cp; 4hpw; prerequisite: 35102 Mathematics 2*

Existence and uniqueness of solutions. Variation of parameters. Qualitative theory of linear and nonlinear systems. Limit cycles. Poincaré-Bendixson theorem. Applications. Boundary value problems, separation of variables. Fourier series. Heat and wave equations. Laplace's equation. Transform methods.

**35232****Advanced Calculus***6cp; 4hpw; prerequisite: 35102 Mathematics 2*

Vector calculus: calculus of several variables, partial derivatives, Taylor's theorem, critical points, Hessians, multiple integrals, line integrals. Complex variables: analytic functions, Cauchy-Riemann equations, complex integrals, Cauchy's theorem, contour integrals, residues.

**35241****Optimisation I**

6cp; 4hpw; prerequisites: 35212 *Linear Algebra*; 35232 *Advanced Calculus*

Operations Research: scope and methodology. Examples of linear, discrete, nonlinear, and dynamic programming problems. Convex sets and convex functions. Simplex method. Revised simplex method. Unconstrained nonlinear programming, first-order and second-order conditions. Method of steepest descent. Constrained nonlinear programming, first-order and second-order conditions. Duality and sensitivity. Basic concepts of dynamic programming; principle of optimality and functional equations.

**35252****Statistics 2**

6cp; 4hpw; prerequisites: 35102 *Mathematics 2*; 35151 *Statistics 1*

Probability. Random variables and their probability distributions. Multivariable probability distributions. Functions of random variables. Sampling distributions and the Central Limit Theorem. Applications to estimation. Multivariate normal distribution.

**35254****Health Statistics**

6cp; 4hpw; prerequisite: 35151 *Statistics 1*

The place of statistical inference in the health sciences. Planning of statistical investigations. Further experimental designs including nested designs and crossover designs. Multiple regression models. Time series and repeated measurements. Categorical data analysis. Survival analysis. Statistical methods in epidemiology. Biological assay. Ethical issues in health statistics.

**35272****Computing 2**

6cp; 6hpw; prerequisites: 35111 *Discrete Mathematics*; 35171 *Computing 1*

Object-oriented design and programming. User-defined recursive data-structures with implementation in an object-oriented imperative language and a functional programming language. Standard problem solving strategies. Analysis of data types and algorithms. Introduction to formal techniques for program specification and design.

**35274****Computing Seminar A**

3cp; 2hpw; prerequisites: see 35376 *Advanced Topics in Computing A*

This subject provides coverage of an advanced topic of contemporary interest in mathematically-based computing. It is drawn from the suite of modules that comprise the Advanced Topics in Computing subjects. The modules to be offered will vary from semester to semester, depending on demand and staff availability. Students cannot choose a module already taken within an Advanced Topics in Computing subject.

**35275****Computing Seminar B**

3cp; 2hpw; prerequisites: see 35376 *Advanced Topics in Computing A*

As for 35274.

**35281****Numerical Analysis I**

6cp; 4hpw; prerequisite: 35170 *Introduction to Computing*; corequisite: 35231 *Differential Equations*

Introduction to numerical analysis, including the study of: solution methods for nonlinear equations, systems of linear equations (LU factorisation and iterative methods), interpolation, numerical differentiation and integration, orthogonal polynomials and approximation theory, the Euler and Runge-Kutta methods for initial value problems, and finite difference methods for boundary value problems. Further work on the use of spreadsheet modelling including coverage of command macros.

**35292–6****Project**

2–6cp; 1–4hpw; prerequisite: by consent; corequisite: by arrangement

A supervised investigation of a topic in an area of interest providing the student with additional skills of direct use in employment or in further academic studies.

**35313****Pure Mathematics 3A**

6cp; 4hpw; prerequisites: 35231 *Differential Equations*; 35232 *Advanced Calculus*

Projective geometry: Euclidean and non-Euclidean geometry, Pappus' and Desargues' theorems, transformations in the plane,



collineations, projectivities, incidence matrices, Latin squares. Differential geometry: vector fields, vector fields on surfaces, Gauss map, Weingarten map, curvature of curves and surfaces.

### 35314

#### Pure Mathematics 3B

6cp; 4hpw; prerequisite: 35111 Discrete Mathematics

Number theory: the division algorithm and unique factorisation in  $\mathbb{Z}$ , number-theoretic functions, congruences, Fermat's theorem, Euler's theorem, linear diophantine equations, continued fractions. Groups: basic definitions, symmetry groups, cyclic groups, generators, relations and presentations of a group, subgroups and cosets, conjugacy and normal subgroups, quotient groups, solvable groups, prime power groups, Sylow theorems. Group homomorphisms and isomorphism theorems. Introduction to rings: homomorphisms, subrings, ideals, quotient rings.

### 35321

#### Analysis I

6cp; 4hpw; prerequisites: 35102 Mathematics 2; 35212 Linear Algebra

Review of sets and functions. Algebraic and order properties of  $\mathbb{R}$ . Countability. Point sets. Application to sequences. Limit of a function: limit theorems, continuity and uniform continuity. Properties of a continuous function on a closed interval. Differentiation. Taylor's theorem with remainder. Review of series, Taylor's series. The Riemann integral. Sequences and series of functions: uniform convergence, Weierstrass M-test. Metric spaces: Cauchy sequences and completeness, the fixed point theorem and applications. Sequentially compact sets in metric space, application to approximation theory. Normed vector spaces: Banach space, finite-dimensional normed spaces, equivalent norms. The Weierstrass approximation theorem.

### 35322

#### Analysis 2

6cp; 4hpw; prerequisite: 35321 Analysis I

Revision of metric spaces. Compact subsets of  $\mathbb{R}$ , the Heine-Borel theorem. Topological spaces: Hausdorff spaces, homeomorphisms. Operators and functionals on normed spaces, the dual space. Inner product spaces. Hilbert space. Hilbert space isomorphism. Measures

and outer measures. Lebesgue and Lebesgue-Stieltjes measure. Borel sets. The Cantor set. Measurable functions, step functions. The Lebesgue integral.  $L^p$  spaces: Hölder and Minkowski inequalities, completeness. Product measures. Probability spaces: random variables, distribution functions, independence, expectation and variance. Modes of convergence: Borel-Cantelli lemmas, laws of large numbers. The Radon-Nikodym theorem. Conditional expectation and conditional probability.

### 35333

#### Applied Mathematics 3A

6cp; 4hpw; prerequisite: 35232 Advanced Calculus; corequisite: 35335 Mathematical Methods

Modelling mechanical properties: force, work, energy, power, projectiles, oscillation, orbits. Modelling electromagnetic properties: electric fields, magnetic fields, Coulomb's law, Biot-Savart law, Ampere's circuital law, Faraday's law, Maxwell's equations.

### 35334

#### Applied Mathematics 3B

6cp; 4hpw; prerequisites: 35333 Applied Mathematics 3A; 35335 Mathematical Methods

Acoustic waves in fluids. Waves on a liquid surface. Elastic waves in solids. Electromagnetic waves.

### 35335

#### Mathematical Methods

6cp; 4hpw; prerequisite: 35231 Differential Equations

Vector integral theorems. Bessel and Legendre equations. Applications to boundary value problems. Integral transform methods for solving boundary value problems.

### 35340

#### Operations Research Practice

6cp; 4hpw; prerequisites: 35241 Optimisation I; 35252 Statistics 2

Financial modelling: mathematics of finance, compound interest, various types of annuities, perpetuities, bond pricing, contingent payments, consumption and investment decisions under certainty, investment decisions under uncertainty, utility theory and risk analysis, Markowitz portfolio theory, single index model, capital asset pricing model. Inventory control: economic order quantity, production lot size model, quantity discounts,

shortage models, single period model, safety stock approach, service level approach, periodic review system, dynamic EOQ, classical optimisation methods, materials requirements planning.

### 35342

#### Optimisation 2

*6cp; 4hpw; prerequisite: 35241 Optimisation 1*

Dual simplex method. Basic ideas of cutting plane and branch-and-bound methods for integer programming. Primal-dual algorithm. Parametric linear programming. Goal programming. Numerical methods for unconstrained nonlinear optimisation; Newton's method, conjugate direction methods. Numerical methods for constrained nonlinear optimisation; feasible direction methods, penalty and barrier methods. Introduction to stochastic programming.

### 35344

#### Network Optimisation

*6cp; 4hpw; prerequisite: 35241 Optimisation 1*

Transportation problems. The transportation simplex method. Assignment problems. Transshipment problems. Shortest path problems. Maximum flow problems. Project planning and scheduling. CPM cost models. Network simulation models. Minimum-cost network flow problems. Network simplex method. Out-of-kilter algorithms. Algorithm analysis. Auction algorithm. Solution of problems using commercially-available software.

### 35353

#### Regression Analysis

*6cp; 4hpw; prerequisite: 35252 Statistics 2*

Simple and multiple linear regression. General linear models. Weighted regression. Diagnostics and model building. Analysis of covariance. Regression graphics. Introduction to nonlinear regression.

### 35354

#### Statistical Inference

*6cp; 4hpw; prerequisite: 35252 Statistics 2*

Point estimation. Sufficiency. Rao-Blackwell theorem. Hypothesis testing. Neyman-Pearson lemma. UMP tests. Likelihood ratio tests. Decision theoretical approaches. Randomisation tests. Sequential probability ratio test.

### 35355

#### Quality Control

*6cp; 4hpw; prerequisite: 35252 Statistics 2*

Total quality management. Process control for attributes and variables, introducing Shewhart, Cusum, and EWMA control charts and covering regular, short, multiple-stream and serially correlated processes. Acceptance sampling for attributes and variables. Process capability analysis including nonconforming ppm, capability ratios and Taguchi quality loss. Tolerance analysis covering linear and nonlinear combinations of components, and Taguchi's method. Reliability analysis including reliability measures, bounds and estimation for individual components and systems, and spare parts provisioning.

### 35356

#### Design and Analysis of Experiments

*6cp; 4hpw; prerequisites: 35212 Linear Algebra; 35252 Statistics 2*

Introduction to general concepts of the design of experiments. Completely randomised, randomised complete block and Latin square designs. Multiple comparisons. Factorial designs. Introduction to Taguchi designs and response surface designs.

### 35361

#### Probability and Stochastic Processes

*6cp; 4hpw; prerequisite: 35252 Statistics 2*

Probability. Random variables and expectations. Limit theorems. Markov chains. The Poisson process. Birth and death processes.

### 35363

#### Simulation Modelling

*6cp; 4hpw; prerequisite: 35170 Introduction to Computing; corequisite: 35361 Probability and Stochastic Processes*

Bayesian statistics and Bayesian decision making, Monte Carlo simulation, prior distributions, decision trees and influence diagrams, conjugate distributions. Various queuing models and applications. Simulation studies, modelling systems and various representations, statistical modelling, input data analysis, verification and validation, output analysis, comparison of systems designs, random number generation and tests, random variate generation, variance reduction techniques.

**35373****Computing 3**

*6cp; 4hpw; prerequisite: 35272 Computing 2*

The characteristics of large complex software systems and design strategies for reducing complexity. Important object-oriented approaches to software construction and their application to substantial modern projects in industry, commerce and science. The use of functional languages for prototyping, including advanced interactive and graphical programming techniques. Computational complexity and the design of efficient data structures and algorithms in functional and imperative languages. A survey of work profiles in the computing industry and review of influential social and ethical issues in its evolution.

**35376****Advanced Topics in Computing A**

*6cp; 4hpw; prerequisites: see individual modules listed below, prerequisites for both modules must be satisfied*

The content of this subject will be drawn from two modules, each focusing on a particular specialist area. The modules to be offered will vary from semester to semester, depending on demand and staff availability, but may include: computer graphics, computing machinery, cryptology, formal analysis of business processes, formal specification, high-performance computing, language translation, and neural networks.

*Module: Computer Graphics*

*prerequisites: 35212 Linear Algebra; 35272 Computing 2*

Overview of graphics hardware and standard graphics software libraries. Mathematical foundation of transformations used in two- and three-dimensional visualisation. Key algorithms for line drawing, clipping and filling. Image creation: hidden line removal, ray tracing. Curve and surface generation: splines. Implementation of key algorithms and use of a graphics software library.

*Module: Computing Machinery*

*prerequisite: 35272 Computing 2*

Historical and social context of computing. Digital logic and digital systems. Finite state machines and their implementation in hardware. Representation of basic data types and associated machine level operations. Structure of processor units and design of a simple central processor unit. Organisation of memory and control of peripherals.

*Module: Cryptology*

*prerequisite: 35272 Computing 2*

Divisibility and prime numbers. Congruences; Fermat's theorem. Application to primality testing and factorisation; Fermat's and Pollard's methods. Multiplicative functions; Euler's function. Block ciphers; exponential ciphers; public key cryptology; knapsack ciphers.

*Module: Formal Analysis of Business Processes*

*prerequisites: 31434 Database Design; 35272 Computing 2*

Aspects of database techniques, structured system analysis and design methods, mathematical modelling and certain techniques from formal methods of specification. Application to the analysis and design of selected business processes, including financial processes. Effective work practices and communication skills.

*Module: Formal Specification*

*prerequisite: 35373 Computing 3*

Formal linguistic systems and the mathematical basis of algebraic and model-based methods of formal specification. Software development by linguistic transformations. Notations, general principles and practical applications of methods of specification and refinement, including Z and the refinement calculus, the Vienna Development Method, the OBJ\* and Larch systems, and rapid prototyping. Effective work practices and communication skills.

*Module: High Performance Computing*

*prerequisites: 35212 Linear Algebra; 35272 Computing 2*

Overview of vector and parallel computer architectures. Case studies in the application of high-performance computing to industrial and research problems. Modified algorithms tailored to high-performance computing: example applications drawn from linear algebra, number theory and searching.

*Module: Language Translation*

*prerequisite: 35272 Computing 2*

Categorisation and specification of grammars. Lexical, syntactic and semantic analysis. Recursive descent and table-driven parsing. Practical compiler-compiler technology. Code generation. Optimisation. Implementation of a compiler for a simple, block-structured imperative language.

Module: *Neural Networks*

prerequisites: 35151 *Statistics 1*; 35171

*Computing 1*; 35232 *Advanced Calculus*; 35281

*Numerical Analysis 1*

Feedforward networks: McCulloch-Pitts neuron, simple perceptron, classification problem, linear separability, convergence theorem, multi-layered perceptrons and hard learning, backpropagation training algorithm, convergence, overfitting. Feedback networks: dynamic systems, attractors, memories, Hebbian learning, spurious memories, optimisation problems.

### 35377

#### Advanced Topics in Computing B

6cp; 4hpw; prerequisite: see 35376 *Advanced Topics in Computing A*

The content of this subject will be drawn from two of the modules described under 35376 *Advanced Topics in Computing A*. The modules chosen by a student for this subject should not include a module already studied as part of 35376 *Advanced Topics in Computing A*. The modules to be offered will vary from semester to semester, depending on demand and staff availability.

### 35378

#### Computing Seminar C

3cp; 2hpw; prerequisite: see 35376 *Advanced Topics in Computing A*

As for 35274.

### 35379

#### Computing Seminar D

3cp; 2hpw; prerequisite: see 35376 *Advanced Topics in Computing A*

As for 35274.

### 35382

#### Numerical Analysis 2

6cp; 4hpw; prerequisite: 35281 *Numerical Analysis 1*

Numerical linear algebra: the algebraic eigenvalue problem, the singular value decomposition and least squares methods. Extrapolation and multistep methods for initial value problems, stiff problems. Boundary value problems: variational and finite element methods. Symbolic computation: programming styles in *Mathematica* (imperative, functional and rule-based), the evaluation engine, use of pattern matching, implementation of standard symbolic and numerical packages.

### 35384

#### Financial Modelling

6cp; 3hpw; prerequisites: 35102 *Mathematics 2*; 35151 *Statistics 1*

Introduction to models of the standard problems of financial management and the mathematical techniques for their solution: asset and liability management, planning day-to-day operations and the firm's financing and investment decisions. Net-present value. Capital budgeting problems; investment under certainty; investment decisions under uncertainty. The debt-capacity decision; debt maturity and timing decisions; dividend policy; internal financing and growth.

### 35391

#### Seminar (Mathematics)

6cp; 4hpw; prerequisite: by arrangement

Group studies in mathematics. The topics will vary from year to year and will be chosen in accordance with the interests of students and staff, and the availability of staff.

### 35392

#### Seminar (Operations Research)

6cp; 4hpw; prerequisite: by arrangement

Group studies in operations research. The topics will vary from year to year and will be chosen in accordance with the interests of students and staff, and the availability of staff.

### 35393

#### Seminar (Statistics)

6cp; 4hpw; prerequisite: by arrangement

Group studies in statistics. The topics will vary from year to year and will be chosen in accordance with the interests of students and staff, and the availability of staff.

### 35394

#### Seminar (Computing)

6cp; 4hpw; prerequisite: by arrangement

Group studies in computing. The topics will vary from year to year and will be chosen in accordance with the interests of students and staff, and the availability of staff.

**35418****Analytic Number Theory**

*4cp; 3hpw; prerequisites: 35314 Pure Mathematics 3B; 35232 Advanced Calculus*

Divisibility, prime numbers and the fundamental theorem of arithmetic; arithmetical functions and Dirichlet multiplication; some asymptotic analysis involving arithmetical functions. Characters of finite Abelian groups; Dirichlet's theorem on primes in arithmetic progressions. The Riemann zeta function; analytic proof of the prime number theorem.

**35419****Advanced Algebra**

*4cp; 3hpw; prerequisite: 35314 Pure Mathematics 3B*

Ring theory: commutative rings, integral domains, field of fractions of an integral domain, polynomial rings, principal ideal domains and unique factorisation. Module theory: left and right modules, submodules, free modules, direct sums of modules, structure of finitely generated modules over a principal ideal domain, application to Abelian groups and linear transformations of a vector space. Galois theory: classical problems of constructibility and solution of algebraic equations by radicals, extension fields and splitting fields of a polynomial, Galois groups, fundamental theorem of Galois theory and applications.

**35427****Functional Analysis**

*4cp; 3hpw; prerequisite: 35322 Analysis 2*

Banach spaces. Bounded linear transformations. Spectrum. Dual space. Adjoint operator. Hahn-Banach theorem. Compact operators. Riesz theory. Fredholm integral equations. Fredholm alternative. Application to potential theory. Hilbert spaces. Operators and adjoints. Riesz representation theorem. Orthogonality. Orthonormal bases. Abstract Fourier theory. Self-adjoint operators. Projections. Compact operators. Spectral theory for compact operators. Application to Sturm-Liouville theory. Fourier series.

**35428****Convexity and Optimisation**

*4cp; 3hpw; prerequisite: 35322 Analysis 2*

Convex sets in a linear space. Affine sets and hyperplanes. Algebraic interior and closure. Separation theorems. Geometric Hahn-Banach theorem. Convex functions. Epigraphs.

Subdifferentiability and differentiability. Duality. Polars. Support functions. Linear and convex programming. Kuhn-Tucker conditions. General constrained optimisation theory; application to calculus of variations; introduction to applications in optimal control theory.

**35436****Advanced Mathematical Methods**

*4cp; 3hpw; prerequisite: 35334 Applied Mathematics 3B*

Generalised functions, Green's functions, applications in electrostatics and electromagnetism. Tensor analysis: tensors from a geometrical viewpoint, metric and curvature tensors, differential forms, Stokes' theorem, applications in special relativity and Maxwell's equations. Use of the symbolic package MathTensor.

**35437****Partial Differential Equations**

*4cp; 3hpw; prerequisite: 35335 Mathematical Methods*

First-order equations. Classification of second-order linear equations. Wave equation. D'Alembert's formula. Poisson's formula. Huygen's principle. Heat equation. Maximum principles. Regularity of solutions. Nonlinear problems. Laplace's equation. Properties of harmonic functions. Green's functions. Method of images. Integral equations. Fredholm theory. Application to Dirichlet and Neumann problems. Introduction to scattering theory. Scattering of plane waves by cylinders.

**35438****Nonlinear Dynamical Systems**

*4cp; 3hpw; prerequisites: 35231 Differential Equations; 35321 Analysis I*

Review of linear systems. Nonlinear systems. Phase plane analysis. Linearisation. Local stability and instability. Global asymptotic stability. Stable and unstable manifolds. Limit cycles and strange attractors. Introduction to chaos theory. Asymptotic methods. The methods of Poincaré and Lindstedt. The method of averaging. Applications to the theory of finance.

**35443****Advanced Mathematical Programming***4cp; 3hpw; prerequisite: 35342 Optimisation 2*

Decomposition methods for large-scale mathematical programming problems. Ellipsoid methods. Karmarkar's projective algorithm. Stochastic programming, two-stage stochastic programming problems.

**35446****Scheduling Theory***4cp; 3hpw; prerequisites: 35342 Optimisation 2; 35447 Discrete Optimisation*

Examples of scheduling problems in manufacturing and service. Deterministic and stochastic mathematical models for scheduling, resources, task systems, sequencing constraints, performance measure. Polynomial-time scheduling algorithms. Computational complexity of scheduling problems. Enumerative methods, branch-and-bound algorithms, dynamic programming. Approximation algorithms. Scheduling and controlling manufacturing.

**35447****Discrete Optimisation***4cp; 3hpw; prerequisites: 35111 Discrete Mathematics; 35342 Optimisation 2*

Example of discrete optimisation problems. Computational complexity, deterministic and nondeterministic Turing machines, NP-completeness and Cook's theorem. Examples of the proofs of NP-completeness. Cutting plane algorithms. Enumerative methods. Partitioning algorithms. Modern heuristic techniques. Performance guarantees for approximation algorithms.

**35448****Dynamic Optimisation***4cp; 3hpw; prerequisites: 35241 Optimisation 1; 35361 Probability and Stochastic Processes; corequisite: 35447 Discrete Optimisation*

Sequential decision processes. Deterministic dynamic programming, principle of optimality and recursive relations. Relation to other fields of mathematical programming. Computational efficiency. Stochastic dynamic programming. Applications of dynamic programming: equipment replacement, resource allocation, inventory control, (s, S)-policies, dynamic portfolio analysis. Markovian decision processes, policy iteration and linear

programming, successive approximation. Applications of the Markov decision model.

**35456****Nonlinear Statistical Models***4cp; 3hpw; prerequisite: 35353 Regression Analysis*

Introduction to nonlinear regression models. Obtaining least-squares estimates of parameters. Obtaining good initial parameter estimates. Obtaining convergence of parameter estimates. Assessing model nonlinearity. Reducing nonlinearity with reparameterisation. Nonlinear mixture models and segmented models.

**35457****Multivariate Statistics***4cp; 3hpw; prerequisite: 35353 Regression Analysis*

Multivariate normal distribution: definition, moments, characteristic function, estimation of mean and covariance matrices, Wishart distribution, Hotelling's  $T^2$ . Multivariate linear regression. Principal components. Factor analysis. Cluster analysis.

**35458****Loglinear Modelling***4cp; 3hpw; prerequisite: 35353 Regression Analysis*

Revision of linear models and exponential families. Generalised linear models. Applications including logistic regression and contingency tables. Modelling using statistical distributions; continuous distribution models; discrete distribution models.

**35459****Linear Models and Experimental Design***4cp; 3hpw; prerequisites: 35353 Regression Analysis; 35457 Multivariate Statistics; 35356 Design and Analysis of Experiments*

Linear models: the linear model of less than full rank, the analysis of variance, completely randomised and randomised block designs. Response surfaces. Incomplete block designs. Repeated measures designs.

**35466****Advanced Stochastic Processes***4cp; 3hpw; prerequisites: 35322 Analysis 2; 35361 Probability and Stochastic Processes*

Formal definitions of probability space and stochastic processes. Martingales. Riemann-Stieltjes integration. Brownian motion and related processes. Stochastic calculus and

stochastic differential equations. Financial applications.

### 35467

#### Time Series Analysis

*4cp; 3hpw; prerequisite: 35361 Probability and Stochastic Processes*

Nonseasonal and seasonal time series model identification, estimation, diagnostic examination and forecasting. Topics covered are time series regression, exponential smoothing, spectral analysis, and Box-Jenkins ARIMA models including stationarity/invertibility criteria, transfer functions, intervention analysis and ARCH/GARCH models.

### 35469

#### Statistical Consulting

*4cp; 3hpw; prerequisites: 35353 Regression Analysis; 35355 Quality Control; 35361 Probability and Stochastic Processes; corequisite: enrolment in any 12cp of core statistics subjects in the Honours program*

Introduction to the general framework of statistical consulting, including a large practical component. Job estimation and business aspects of consulting. Recognition of and searching for appropriate techniques to solve particular problems. Constraints imposed by the analysis time frame. Communication of results in written, graphical and oral forms to lay and technical audiences. Ethical issues.

### 35485

#### Advanced Financial Modelling

*4cp; 3hpw; prerequisite: 35340 Operations Research Practice*

Options and futures: concepts and valuation models, current issues and developments. Capital structure and theory of the firm: the effects of corporate and personal taxation on the capital structure of a firm, dividend policy, current issues.

### 35486

#### Optimal Control I

*4cp; 3hpw; prerequisites: 35231 Differential Equations; 35232 Advanced Calculus*

Problems of the calculus of variations and optimal control. Terminology and notation, historical development, formulation, necessary and sufficient conditions for optimality, the maximum principle, various endpoint conditions, inclusion of constraints of various

types, bang-bang and singular controls, infinite horizon problems, dynamic programming, applications in continuous and discrete time.

### 35487

#### Optimal Control 2

*4cp; 3hpw; prerequisites: 35466 Advanced Stochastic Processes; 35486 Optimal Control I*

Formulation of stochastic control problems. Examples of controls. The Hamilton-Jacobi-Bellman equation. Necessary and sufficient conditions. Reduction to Markov controls. Dynamic portfolio strategies. The optimal portfolio selection problem. Discussion of solutions in particular cases.

### 35491

#### Honours Seminar A

*4cp; 3hpw; prerequisite: by consent*

This subject will provide an opportunity for students to benefit from the specialist knowledge of a visitor to the School or to undertake a course in an area of specific staff research or knowledge.

### 35492

#### Honours Seminar B

*4cp; 3hpw; prerequisite: by consent*

As for 35491.

### 35496

#### Thesis Seminar A

*4cp; 3hpw; prerequisite: by consent*

This subject is intended to provide essential background to the Thesis (Honours) or opportunities for study in areas related to the thesis, complementing the project or providing further research in the area. The subject is operated as a reading course, with the studies being coordinated by the thesis supervisor.

### 35497

#### Thesis Seminar B

*4cp; 3hpw; prerequisite: by consent*

As for 35496.

### 35498

#### Thesis (Honours)

*16cp; prerequisite: by consent*

Students will perform an independent investigation of an area of the mathematical sciences chosen in consultation with a supervisor who will be appointed by the Head of School. This is a year-long subject. Students

are expected to spend three hours per week on their project in Autumn semester and six hours per week in Spring semester.

### 35545

#### Further Methods in Operations Research

6cp; 4hpw; prerequisites: 35151 Statistics 1; 35342 Optimisation 2

Financial, manufacturing, service, and transportation applications of discrete optimisation and deterministic and stochastic dynamic programming. Approximation algorithms and modern heuristic techniques for discrete optimisation.

### 35549

#### Case Studies in Management Science

6cp; 4hpw; prerequisites: 35340 Operations Research Practice; 35342 Optimisation 2; 35363 Simulation Modelling

Problem summary using rich pictures; problem identification; identification of the structure, transformation processes, components, inputs and outputs of a system. Project proposal development. Mathematical modelling. Modelling costs, benefits, constraints, time, uncertainty and multiple goals. Validation and performance testing; sensitivity and error analysis.

### 35592-6

#### Project

4,6,8,10,12cp; prerequisite: by arrangement

A supervised investigation of a topic in an area of interest providing the student with additional skills of direct use in employment.

### 35599

#### Report

12cp; prerequisite: by consent

An applied or theoretical study in an area chosen in consultation with the project supervisor who will be appointed by the Head of School. This is a year-long subject. Students are expected to spend three hours per week on their project in Autumn semester and six hours per week in Spring semester.

## SUBJECTS OFFERED BY OTHER FACULTIES

Students should consult the relevant faculty and its handbook for any late changes to subject information.

### 015110

#### Aboriginal Cultures and Philosophies

8cp; 3hpw

This subject will introduce participants to Aboriginal culture and social organisation as expressions of Aboriginal cosmology. Contemporary Aboriginal culture will be presented as an evolving response to colonialism and as a reassertion of cultural empowerment.

### 22105

#### Accounting A

4cp; 3hpw

This subject provides an introduction to accounting, setting out the nature of accounting and its relationships together with double entry bookkeeping's unique ability to record market activity. The body of the course deals with the accounting process (journals to ledger), double entry bookkeeping, definition of the elements of financial statements, using control accounts, control of cash, using accrual accounting, inventory, non-current assets, preparation of financial statements, and the so-called limitations of the historical cost model.

### 25110

#### Microeconomics

4cp; 3hpw

Basic market theory. Demand theory. Elasticity of demand. Short-run cost theory. Short-run supply theory, long-run cost theory. Resource market theory. Perfect and monopolistic competition. Oligopoly and monopoly. Firm behaviour, theory of competition policy. Theory of trade. Market failure theory. Income redistribution. Industry policy, regulation.

### 25209

#### Macroeconomics

4cp; 3hpw; prerequisite: 25110 Microeconomics

Inflation and unemployment. Aggregate supply and demand. National accounts. Elementary income determination theory. Interest rates and expenditure. The monetary sector. Combining money and expenditure



sectors. The balance of payments. Prices, wages and the Phillip's curve. Stagflation.

## 25210

### Microeconomic Theory and Policy

*6cp; 4hpw; prerequisite: 25110 Microeconomics*

The need for public regulation and/or control of business activity. Microeconomic policy formulation, theory of firms and markets, restrictive trade practices, consumer protection, small business. Industry policy, tariffs and structural change. Foreign investment. Resources policy.

## 25308

### Financial Markets

*4cp; 3hpw*

Financial intermediation. Interest rate determination. Financial market theory, bond pricing, foreign exchange market futures, options and swaps. The financial system and the Reserve Bank. Introduction to banking. Equity market.

## 25314

### Business Finance

*4cp; 3hpw; prerequisites: 22105 Accounting A; 35151 Statistics 1; corequisite: 25308 Financial Markets*

Consumption/investment decision: investment decision and techniques for evaluation. Factors affecting investment: the concept of risk, the pricing of risk, investment decisions under risk, the financing decision. Sources of finance, leasing. Capital structure theories, dividend policy.

## 25421

### International Financial Management

*6cp; 4hpw; prerequisites: 25308 Financial Markets; 25314 Business Finance*

International financial management, mechanics and functions of foreign exchange markets, exchange rate determination and parity relationships, forecasting, measurement of foreign exchange risk, multinational working capital management, trade finance, financing foreign operations, long-term asset and liability, international taxation management.

## 25606

### Financial Time Series Analysis

*6cp; 4hpw; prerequisites: 35232 Advanced Calculus; 35353 Regression Analysis*

Financial returns: their definitions and behaviour. Models of price volatility. Forecasting standard deviations. Testing the random walk hypothesis. Testing the market efficiency hypothesis. Forecasting trends in prices. Valuing options.

## 25620

### Derivative Securities

*6cp; 4hpw; prerequisite: 25906 Investment Analysis (Honours)*

Introduction to derivative securities, basic arbitrage arguments, the pricing of futures, properties of options, pricing of differing instruments and hedging strategies using derivatives.

## 25621

### Financing Decisions and Capital Market Theory

*6cp; 4hpw; prerequisite: 25905 Capital Budgeting and Valuation (Honours)*

Provides an understanding of the theory, empirical evidence and practice of corporate financing decisions. Critical evaluation of a company's existing capital structure and proposed methods of raising new finance. Review of theoretical and empirical research relating to the efficient market hypothesis.

## 25905

### Capital Budgeting and Valuation (Honours)

*6cp; 4hpw; prerequisites: 25308 Financial Markets; 25314 Business Finance*

The contribution of Markowitz and others to modern portfolio theory and the Capital Asset Pricing Model, including market equilibrium and efficient market assumptions; empirical tests. Relating to the Capital Asset Pricing Model and its derivatives. Arbitrage Pricing Theory. Pricing models for contingent claims, options and futures. Efficient capital markets: theory and evidence.

**25906****Investment Analysis (Honours)**

6cp; 4hpw; prerequisites: 25308 *Financial Markets*; 25314 *Business Finance*

Equilibrium models. Performance measures. Pricing instruments. Options. Return profiles. Option valuation models. Market efficiency. Share market analysis. Fixed income securities. International diversification.

**25907****Theory of Financial Decision Making**

4cp; 3hpw; prerequisite: by consent

The theory of choice. State preference theory. The mean-variance criteria. Capital market equilibrium, capital asset pricing model and arbitrage pricing theory. Efficient capital markets: theory and evidence.

**25908****Derivative Security Pricing**

4cp; 3hpw; prerequisite: by consent

Introduction to derivative securities. Basic arbitrage arguments. Geometric Brownian motion model of asset pricing movements. Ito's lemma. Risk-neutral valuation and the Black-Schole's model. Currency and futures options. Hedging techniques. Interest-rate-derivative securities. Alternatives to Black-Schole's option pricing.

**25909****Advanced Corporate Finance**

4cp; 3hpw; prerequisite: by consent

A selection of the classic papers in corporate finance. Current research work, Australian empirical work. Major issues involved in the firm's investment and financing decisions, the interaction of these activities and investor behaviour in the markets for the firm's securities.

**25910****Thesis**

1/2cp; prerequisite: by consent

A thesis on a topic chosen by the student in consultation with his or her supervisor.

**50140****Modernisation and Social Change**

8cp; 4hpw

The aim of this subject is to provide students with an understanding of the processes of modernisation and social change in a comparative context using case studies in countries of Western Europe, Latin America, East and South-East Asia. The lectures will highlight a number of key issues, for example whether the processes of social change are universal or specific; the consequences of modernisation in and for the economy, politics, society, culture and ideology of non-Western societies; and whether the established Eurocentric analytical models are still useful in understanding the modern world. It will be emphasised that differing interpretations of modernisation flow from various relations of power which lead to a multiplicity of views on its meanings and significance.

**54230****Aboriginal Social and Political History**

8cp; 3hpw

Examines and analyses the impact of colonialism on indigenous peoples, with particular reference to the Aboriginal inhabitants of this region. The emergence of Aboriginal social and political movements will be presented as the basis for repossession of their traditional heritage in land and culture.

**54231****Aboriginal People and the Media**

8cp; 3hpw; prerequisites: 015110 *Aboriginal Cultures and Philosophies*; 54230 *Aboriginal Social and Political History*

Familiarises students with the field of debate in relation to the representation of Aborigines in the media, and with the productions of Aboriginal media organisations. Where possible, some written, video or film production could become part of the course assessment.

**54330****The Politics of Aboriginal History**

*8cp; 3hpw; prerequisites: Aboriginal Studies subjects at 100 and 200 levels*

Introduces students to the wide range of historical work by Aboriginal and non-Aboriginal people over the last three decades, and encourages students to develop skills in the critical evaluation of this work in its political and social contexts. Students will enhance their knowledge of primary research materials for the field of Aboriginal history, and will develop their skills in the analysis and use of these sources.

**54331****Aboriginal Forms of Discourse**

*8cp; 3hpw; prerequisites: 015110 Aboriginal Cultures and Philosophies; one Aboriginal Studies subject at the 200 level*

Familiarises students with a broad range of Aboriginal forms of discourse – novels, plays, films, oral narratives – and introduces them to methods of analysis, of both text and content, deriving from the disciplines of cultural studies and textual studies.

**79202****Business Law**

*4cp; 3hpw*

Legal philosophy; legal history; constitutional law; torts; crime; property; contracts; consumer protection.

**INTERNATIONAL STUDIES SUBJECTS****971111, 972111, 973111, 974111****Chinese Language and Culture 1**

*8cp; 6hpw; prerequisite: nil*

Chinese 1 aims at developing in students a survival communicative ability in basic social interactions. It teaches students *Pinyin*, the official transcription system, as a guide to the pronunciation of the Chinese language, and some basic structures and devices of the language. Students are expected to know about 300 Chinese characters by the end of this unit.

**Chinese Language and Culture 2**

*8cp; 6hpw; prerequisite: Chinese 1*

Chinese 2 continues to develop in students a survival communicative ability in basic social interactions. It also introduces students to some of the basic structures and devices of the language. Students are expected to know about 600–800 Chinese characters by the end of this unit.

**Chinese Language and Culture 3**

*8cp; 6hpw; prerequisite: Chinese 2 or HSC Chinese*

Chinese 3 is the entry point for students who have completed HSC 2/3 Unit Chinese and who first learnt Chinese at school in Australia.

Chinese 3 aims at further developing students' oral communicative competence in basic social interactions. More written texts will be gradually introduced to enhance the ability of students to use Chinese characters. The basic structures and devices of the language will be reinforced. Students are expected to know about 1,200 Chinese characters by the end of this unit.

**Chinese Language and Culture 4**

*8cp; 2nd semester, 6hpw; prerequisite: Chinese 3*

Chinese 4 is the second unit for students who have completed HSC 2/3 Unit Chinese.

Chinese 4 aims at further developing students' communicative competence in basic social interactions. More written texts are introduced to enhance the ability of students to use Chinese characters. The basic structures and devices of the language are also reinforced. Students are expected to know about 1,600 Chinese characters by the end of this unit.

### Chinese Language and Culture 5

8cp; 1st semester, 6hpw; prerequisite: Chinese 4

Chinese 5 is the third unit for students who first learnt Chinese at school in Australia and obtained HSC-level Chinese.

Chinese 5 aims at further developing students' communicative competence in general social interactions. While reinforcing the macro-skills of reading, writing, listening and speaking, this unit will focus on practical writing skills. Students are expected to know about 2,000 Chinese characters by the end of this unit.

### Chinese Language and Culture 6

8cp; 6hpw; prerequisite: Chinese 5

Chinese 6 is the fourth subject for students who have obtained HSC 2/3 Chinese with basic communicative skills and the ability to undertake In-country Study in China.

Chinese 6 aims at further developing students' communicative competence in general social interactions. While reinforcing basic structures and devices of the language, this unit will further develop students' writing skills. Students are expected to know about 2,500 Chinese characters by the end of this unit.

### Chinese Language and Culture 7

8cp; 4hpw; prerequisite: a working knowledge of Chinese characters as well as communicative competence in a Chinese language other than Modern Standard Chinese.

Chinese 7 is for students who have a working knowledge of Chinese characters as well as communicative competence in a Chinese language other than Modern Standard Chinese.

This unit aims at developing communicative competence to meet students' needs in social and professional interactions where Modern Standard Chinese (also known as Mandarin, *Putonghua* or *Guoyu*) is used. Simplified characters, pronunciation, intonation and situational Chinese usages are the focus of class instruction.

### Chinese Language and Culture 8

8cp; 4hpw; prerequisite: Chinese 7 or equivalent

This unit aims at developing a communicative competence at a more sophisticated level. Students are exposed to a range of Chinese texts in varied socio-cultural contexts to master Chinese for different purposes, and are provided with opportunities to further improve speaking and listening skills through discussions of the texts and making cross-cultural comparisons.

### Chinese Language and Culture 9

8cp; 4hpw; prerequisite: Chinese 8 or equivalent

This unit aims at developing in students a high level of communicative competence required for understanding various electronic and published media articles, correspondence and texts related to contemporary society where Modern Standard Chinese (also known as Mandarin, *Putonghua* or *Guoyu*) is used. Students are exposed to a range of Chinese texts to master Chinese for different purposes, and are provided with opportunities to maintain speaking and listening skills through discussion of texts.

### Chinese Language and Culture 10

8cp; 4hpw; prerequisite: Chinese 9 or equivalent

This unit aims at further developing in students a high level of communicative competence in reading and writing to meet students' needs in social and professional interactions where Modern Standard Chinese (also known as Mandarin, *Putonghua* or *Guoyu*) is used. Students are exposed to a range of diverse texts of modern Chinese literature, history, language and culture to master written Chinese for different purposes, and are provided with further opportunities to maintain speaking and listening skills through discussion of the texts.

## 971121, 972121, 973121, 974121

### Cantonese Language and Culture A-1

8cp; 1st semester, 6hpw; prerequisite: nil

Cantonese A-1 is the first subject in the Cantonese A program. It is designed to provide students who have no prior knowledge of Cantonese with basic survival skills in language and culture, and the ability to undertake In-country Study in South China.

This subject aims at developing in students a survival communicative ability in basic social interactions. It also deals with the basic language structures and devices of Cantonese. Students will be taught the basic structures of Chinese writing and are expected to know about 150 Chinese characters by the end of the subject.

Cantonese A-1 consists of 78 hours of classroom instruction, involving many interactive group and pair-work activities. Audiovisual equipment and computers will be used to facilitate teaching and learning. A communicative approach is adopted for classroom instruction and students are expected to participate actively in all classroom

activities in the process of acquiring language skills. The teaching incorporates an introduction to Cantonese culture and helps students to appreciate the wider cultural ramifications of Cantonese in various contexts.

### **Cantonese Language and Culture A-2**

*8cp; 2nd semester, 6hpw; prerequisite: Cantonese A-1*

Cantonese A-2 is the second subject in the Cantonese A program. It is designed to provide students who have no prior knowledge of Cantonese with basic survival skills in language and culture, and the ability to undertake In-country Study in South China.

This subject aims at developing in students a communicative and linguistic competence in basic social interactions. It also deals with some of the basic structures and devices of Cantonese. Students will be taught the basic structures of Chinese writing and are expected to know about 300 Chinese characters by the end of the subject.

Cantonese A-2 consists of 78 hours of classroom instruction, involving many interactive group and pair-work activities. Audiovisual equipment and computers will be used to facilitate teaching and learning. A communicative approach is adopted for classroom instruction and students are expected to participate actively in all classroom activities in the process of acquiring language skills. The teaching incorporates an introduction to Cantonese culture and helps students to appreciate the wider cultural ramifications of Cantonese in various contexts.

### **Cantonese Language and Culture A-3**

*8cp; 1st semester, 6hpw; prerequisite: Cantonese A-2*

Cantonese A-3 is the third subject in the Cantonese A program. It is designed to provide students who have no prior knowledge of Cantonese with basic survival skills in language and culture, and the ability to undertake In-country Study in South China.

This subject aims at developing in students a communicative and linguistic competence in general social interactions. It also deals with the language structures and devices of Cantonese. Discourse features such as registers and polite forms will be discussed. More Cantonese vocabulary and idiomatic expressions will be introduced. Students are expected to know about 500 Chinese characters by the end of the subject.

Cantonese A-3 consists of 78 hours of classroom instruction, involving many

interactive group and pair-work activities. Audiovisual equipment and computers will be used to facilitate teaching and learning. A communicative approach is adopted for classroom instruction and students are expected to participate actively in all classroom activities in the process of acquiring language skills. The teaching incorporates an introduction to Cantonese culture and helps students to appreciate the wider cultural ramifications of Cantonese in various contexts.

### **Cantonese Language and Culture A-4**

*8cp; 2nd semester, 6hpw; prerequisite: Cantonese A-3*

Cantonese A-4 is the last subject in the Cantonese A program. It is designed to provide students who have no prior knowledge of Cantonese with basic survival skills in language and culture, and the ability to undertake In-country Study in South China.

This subject aims at developing in students a communicative and linguistic competence in general social interactions. It deals with the more complex language structures and devices of Cantonese. A number of Cantonese discourse features will be discussed. More Cantonese vocabulary and idiomatic expressions will be introduced. Students are expected to know about 800 Chinese characters by the end of the subject.

Cantonese A-4 consists of 78 hours of classroom instruction, involving many interactive group and pair-work activities. Audiovisual equipment and computers will be used to facilitate teaching and learning. A communicative approach is adopted for classroom instruction and students are expected to participate actively in all classroom activities in the process of acquiring language skills. The teaching incorporates an introduction to Cantonese culture and helps students to appreciate the wider cultural ramifications of Cantonese in various contexts.

### **Cantonese Language and Culture B-1**

*8cp; 1st semester, 4hpw; prerequisite: a working knowledge of one of the Chinese languages*

Cantonese B-1 is the first of a two-subject language program for students who have a working knowledge of at least one Chinese language to prepare them for a year of In-country Study in South China.

This subject aims at developing the students' communicative and linguistic competence in general social interactions where Cantonese is used. The Yale romanisation for transcribing

Cantonese and pronunciation will be discussed in class. Situational Cantonese usages in different contexts are the main focus of class instruction. The teaching incorporates an introduction to Cantonese culture and helps students to appreciate the wider cultural ramifications of Cantonese in various contexts.

Cantonese B-1 consists of 52 contact hours of classroom instruction, involving many interactive group and pair-work activities. Audiovisual equipment and computers will be used to facilitate teaching and learning. The teaching approach adopted is 'communicative' and students are expected to participate actively in all classroom activities in the process of acquiring language skills.

### **Cantonese Language and Culture B-2**

*8cp; 2nd semester, 6hpw; prerequisite: Cantonese B-1*

Cantonese B-2 is the second of a two-subject language program for students who have a working knowledge of at least one Chinese language to prepare them for a year of In-country Study in South China.

This subject aims at further developing the students' communicative and linguistic competence in general social interactions where Cantonese is used. Situational Cantonese usages and vocabulary in different contexts are the main focus of class instruction. Discourse features of Cantonese will also be discussed. The teaching incorporates an introduction to Cantonese culture and helps students to appreciate the wider cultural ramifications of Cantonese in various contexts.

This subject consists of 52 contact hours of classroom instruction, involving many interactive group and pair-work activities. Audiovisual equipment and computers will be used to facilitate teaching and learning. The teaching approach adopted is 'communicative' and students are expected to participate actively in all classroom activities in the process of acquiring language skills.

**971211, 972211, 973211, 974211**

### **Japanese Language and Culture I**

*8cp; 1st semester, 6hpw; prerequisite: nil*

This is the first subject in the Japanese Language and Culture program. It is designed as the first step in providing students with no prior knowledge of Japanese with the basic survival language skills and socio-cultural awareness to enable them to undertake In-country Study in Japan.

While focusing primarily on the development of speaking and listening skills, this subject also provides a working knowledge of the *hiragana* and *katakana* scripts and approximately 50 *kanji*. Socio-cultural aspects are integrated into the program as they relate to the need for students to learn to use the language appropriately in various social and cultural contexts.

### **Japanese Language and Culture 2**

*8cp; 2nd semester, 6hpw; prerequisite: Japanese 1*

This is the second in a series of four units for students with no prior knowledge of the Japanese language. By the completion of this subject, students should be able to demonstrate the language and socio-cultural skills required to establish and maintain relationships in social or work-related spheres, and fulfil basic survival needs in a Japanese-speaking environment.

Emphasis is given to the development of speaking and listening skills, but students will also further develop their reading and writing skills. Besides *kana* they will know approximately 150 *kanji* by the end of the unit. Socio-cultural aspects are introduced into the program as they relate to the need for students to learn to use the language appropriately in various social and cultural contexts.

### **Japanese Language and Culture 3**

*8cp; 1st semester, 6hpw; prerequisite: Japanese 2 or HSC Japanese*

Japanese 3 is the third in a series of four units for students with no prior knowledge of the Japanese language, or first in a series of four units for students who have successfully completed HSC-level Japanese. By the end of the subject, students are expected to have achieved survival proficiency, and be able to satisfy survival needs and limited social demands relating to topics and situations covered.

At the end of the subject, students are expected to have developed their listening, speaking, reading and writing skills in order to be able to communicate in everyday situations, and be able to demonstrate an awareness of the social implications of language and behaviour.

It is expected that students will know approximately 250 *kanji* by the end of the unit.

**Japanese Language and Culture 4***8cp; 2nd semester, 6hpw; prerequisite: Japanese 3*

Japanese 4 is the fourth in a series of four units for beginners. It is also the second in a series of four units for those who have successfully completed the 2-unit HSC course or its equivalent and aim to further develop Japanese listening, speaking, reading and writing skills. By the end of the subject, students are expected to have achieved limited social proficiency, and be able to interact in limited social, study and work contexts with Japanese speakers in Japan or Australia. They will also have learnt approximately 350 *kanji*.

**Japanese Language and Culture 5***8cp; 1st semester, 6hpw; prerequisite: Japanese 4*

Japanese 5 is the third in a series of four units in the post-HSC series, and is for those who have successfully completed either Japanese 4 or its equivalent and aim to further develop listening, speaking, reading, writing and cultural skills. By the end of the subject, students are expected to have achieved limited social proficiency, and be able to satisfy routine social and limited work demands. The emphasis is on the development of the language and cultural sensitivity required in both formal and informal situations. By the end of the subject, students are expected to be able to read and write approximately 470 *kanji*.

**Japanese Language and Culture 6***8cp; 2nd semester, 6hpw; prerequisite: Japanese 5*

Japanese 6 is the final subject in a series of four units in the post-HSC series and is for those who have successfully completed either Japanese 5 or its equivalent. By the end of this subject, students are expected to have achieved minimal vocational proficiency, and be able to speak the language with sufficient structural accuracy and vocabulary to participate effectively in many formal and informal conversations on practical, social and limited vocational topics. The emphasis is on the development of the language and cultural sensitivity required in both formal and informal situations. By the end of the subject, students should be able to read simple prose and read and write approximately 590 *kanji*.

**971311, 972311, 973311, 974311****Indonesian Language and Culture 1***8cp; 1st semester, 6hpw; prerequisite: nil*

Indonesian 1 is the first in a series of four units for students with no prior knowledge of Indonesian. By the end of the subject, students are expected to have achieved elementary proficiency and be able to satisfy immediate needs using learnt utterances and phrases relating to the following 10 themes: self and family; direction and location; time; food and drink; buying and selling; description; archipelago and continent; travel and transport; media and the press; and love and sex.

Students are expected to develop a vocabulary of about 800–1,000 words, a knowledge of basic word-order patterns, and a familiarity with the alphabet and pronunciation patterns. This subject prepares people to exchange basic personal information using spelling and numeracy skills for names, addresses and time references etc.; engage in brief conversations within the range of themes covered; and express immediate needs with socially appropriate phrases. Students should be able to understand a limited amount of everyday written language e.g. on signs and in menus.

**Indonesian Language and Culture 2***8cp; 2nd semester, 6hpw; prerequisite: Indonesian 1*

Indonesian 2 is the second in a series of four units for students with no prior knowledge of Indonesian. By the end of the subject, students are expected to have achieved minimum survival proficiency, and be able to satisfy basic survival needs and minimum courtesy requirements relating to the following 10 themes: health; house and home; contacts and appointments; education and study; career and occupations; city and village; religion and beliefs; personalities and biography; letters; and Australia–Indonesia relations.

Students are expected to develop a vocabulary of about 1,600–2,000 words, a knowledge of common word-order patterns and the ability to recognise common affixational patterns. This subject prepares students to make simple appointments and arrangements with people, exchange personal background information, engage in five- to ten-minute conversations on the themes covered, and express feelings, likes and dislikes. Students should be able to understand short, practical pieces of written information, such as familiar signs, commands and timetables, and develop skills for reading longer, less familiar written forms.



### Indonesian Language and Culture 3

*8cp; 1st semester, 6hpw; prerequisite: Indonesian 2 or HSC Indonesian*

Indonesian 3 is the third in a series of four units for students with no prior knowledge of Indonesian, or first in a series of four units for students who have successfully completed HSC-level Indonesian. By the end of the subject, students are expected to have achieved survival proficiency, and be able to satisfy survival needs and limited social demands relating to the following themes: personal relations; education – young generation; students; politics; ‘pop’ culture; religion and beliefs; tourism and its influences; trade; and economics and business.

Students are expected to develop a vocabulary of about 3,000 words by the end of the subject, a knowledge of common word-order patterns, and the ability to recognise, predict and use common affixational patterns. This subject prepares students to engage in short conversations on familiar issues without undue hesitation and with an ability to express their opinion. Students should also be able to comprehend simple texts, such as messages, instructions and directions, and write simple formulaic letters.

### Indonesian Language and Culture 4

*8cp; 2nd semester, 6hpw; prerequisite: Indonesian 3*

Indonesian 4 is the fourth in a series of four units for students with no prior knowledge of Indonesian, or second in a series of four units for students who have successfully completed HSC-level Indonesian. By the end of the subject, students are expected to have begun to develop minimum social proficiency, and be able to satisfy limited routine social and work demands. The subject covers the following themes: the role of women; employment/labour; employers; mainstream/marginal cultures; literature; unity and diversity (multiculturalism); the environment; and Australia-Indonesia relations.

Students are expected to have developed a vocabulary of about 4,000 words by the end of the subject. They should also have developed an ability to recognise, predict and use common word-order and affixational patterns, and to participate in a limited range of social situations with appropriate language. This subject prepares students to be able to discuss familiar events and topics, and give opinions without undue hesitation and with the ability to justify themselves. Students should also be

able to deal with short texts and correspond with Indonesians on familiar topics.

### Indonesian Language and Culture 5

*8cp; 1st semester, 6hpw; prerequisite: Indonesian 4*

Indonesian 5 is the third in a series of four units for students who have successfully completed HSC-level Indonesian. By the end of the subject, students are expected to have developed minimum social proficiency, and be able to satisfy routine social and limited work demands. The subject covers the following themes: perceptions of the past; the origin of the New Order; aspirations; achievements; problems; political culture and participation; class and social stratification; and gender.

Students completing the subject should have a vocabulary of about 5,000 words. They should have the ability to recognise and reflect on ways in which vocabulary and grammatical patterns vary in different situational contexts, and how choices in grammar and vocabulary can convey the point of view of the writer and speaker beyond the basic transmission of information. This subject prepares students to discuss a range of social topics and a limited range of work topics, and present rudimentary arguments or points of view expressed with socially appropriate phrases to limit possible misunderstanding or offence. Students should also be able to understand the general thread of articles and documents on familiar topics, and write short texts, such as letters and instructions.

### Indonesian Language and Culture 6

*8cp; 2nd semester, 6hpw; prerequisite: Indonesian 5*

Indonesian 6 is the fourth in a series of four units for students who have successfully completed HSC-level Indonesian. By the end of the subject, students are expected to have begun to develop a minimum vocational language proficiency, and be able to satisfy all routine social and a significant range of work demands. The subject covers the following themes: social and cultural pluralism; national and economic development; science; technical and scientific development; religion and popular culture; and internationalisation.

Students should have a vocabulary of about 6,000 words by the end of the subject. They should also have the ability to vary their language appropriately in accordance with a range of social and work situations, and be able to recognise and manipulate vocabulary and grammatical patterns. This subject prepares students to be able to present arguments or



points of view, with the ability to frame them in a style that is appropriate to the social, cultural and interpersonal factors present. Students should also be able to understand articles and documents on familiar topics, and write short texts, such as letters, descriptions and simple explanations.

### **971320, 972320, 973320, 974320**

#### **Thai**

Thai is offered to UTS students through the language program offered jointly by the University of Sydney and Macquarie University. The program is designed to allow complete beginners in Thai to reach a survival level that will allow them to continue their studies in Thailand. If student numbers permit, classes will be available on UTS campuses.

### **971331, 972331, 973331, 974331**

#### **Malaysian Language and Culture 1**

*8cp; 1st semester, 6hpw; prerequisite: nil*

Malaysian 1 is the first in a series of four units for students with no prior knowledge of the language. By the end of the subject, students are expected to have achieved elementary proficiency and be able to satisfy immediate needs using learnt utterances and phrases relating to the following 10 themes: self and family; direction and location; time; food and drink; buying and selling; description; archipelago and continent; travel and transport; media and the press; and love and sex.

Students are expected to develop a vocabulary of about 800–1,000 words, a knowledge of basic word order patterns and familiarity with the alphabet and pronunciation patterns. This subject prepares people to exchange basic personal information using spelling and numeracy skills for names, addresses and time references, to engage in brief conversations within the range of themes covered, and express immediate needs with socially appropriate phrases. Students should be able to understand a limited range of everyday written language, such as signs and items and prices on menus.

#### **Malaysian Language and Culture 2**

*8cp; 2nd semester, 6hpw; prerequisite: Malaysian 1*

Malaysian 2 is the second in a series of four units for students with no prior knowledge of Malaysian. By the end of the subject, students are expected to have achieved minimum survival proficiency and to be able to satisfy

basic survival needs and minimum courtesy requirements relating to the following 10 themes: health; house and home; contacts and appointments; education and study; career and occupations; city and village; religion and belief; personalities and biography; letters; and Australia–Malaysia relations.

Students are expected to develop a vocabulary of about 1,600–2,000 words, a knowledge of common word order patterns and the ability to recognise common affixational patterns. This subject prepares students to make simple appointments and arrangements with people, exchange personal background information, engage in five- to ten-minute conversations on the themes covered and express limited feelings, likes and dislikes. Students should be able to understand short practical written information, such as familiar signs, commands and timetables and develop skills for reading longer, less familiar written forms.

#### **Malaysian Language and Culture 3**

*8cp; 1st semester, 6hpw; prerequisite: Malaysian 2*

Malaysian 3 is the third in a series of four units for students with no prior knowledge of Malaysian, or first in a series of four for students who have prior knowledge or experience in Malaysian. By the end of the subject, students are expected to have achieved survival proficiency and be able to satisfy survival needs and limited social demands relating to the following themes: personal relations; education – young generation; students; politics; ‘pop’ culture; religion and belief; tourism and its influences; trade; economics; and business.

Students are expected to develop a vocabulary of about 3,000 words by the end of the subject, a knowledge of common word order patterns and the ability to recognise, predict and use common affixational patterns. This subject prepares students to engage in short conversations on familiar issues without undue hesitation and with a limited ability to express opinions. Students should also be able to comprehend simple texts, such as messages, instructions and directions and write simple formulaic letters.

#### **Malaysian Language and Culture 4**

*8cp; 2nd semester, 6hpw; prerequisite: Malaysian 3*

Malaysian 4 is the fourth in a series of four units for students with no prior knowledge of Malaysian, or second in a series of four units for students who have prior knowledge or experience of Malaysian. By the end of the

subject, students are expected to have begun to develop 'minimum social proficiency' and be able to satisfy limited routine social and work demands demonstrating the following themes: role of women; employment/labour; employers; mainstream/marginal cultures; literature; unity and diversity (multi-culturalism); the environment; and Australia–Malaysia relations.

Students are expected to have developed a vocabulary of about 4,000 words and an ability to recognise, predict and use common word order and affixational patterns and recognise and respond to a limited range of social situations. This subject prepares students to discuss familiar events and topics and give opinions without undue hesitation and with a limited ability to justify these opinions. Students should also be able to deal with short texts and correspond with Malaysians on familiar topics.

### **Malaysian Language and Culture 5**

*8cp; 1st semester, 6hpw; prerequisite: Malaysian 4*

Malaysian 5 is the third in a series of four units for students who have had prior experience of Malaysian. By the end of the subject, students are expected to have developed minimum social proficiency and be able to satisfy routine social and limited work demands. The subject covers the following themes: perceptions of the past; aspirations, achievements, problems; political culture and participation; class and social stratification; and gender.

Students completing the subject should have a vocabulary of about 5,000 words, and the ability to recognise and reflect on ways in which vocabulary and grammatical patterns vary according to situation, and how choices in grammar and vocabulary can convey the point of view of the reader and speaker beyond the basic transmission of information. This subject prepares students to discuss a range of social topics and limited range of work topics and present rudimentary arguments or points of view expressed with socially appropriate phrases to limit possible misunderstanding or offence. Students should also be able to understand the general thread of articles and documents on familiar topics and write short texts, such as letters and instructions.

### **Malaysian Language and Culture 6**

*8cp; 2nd semester, 6hpw; prerequisite: Malaysian 5*

Malaysian 6 is the fourth in a series of four units for students who have had prior experience of Malaysian. By the end of the

subject, students are expected to have begun to develop minimum vocational proficiency and to be able to satisfy all routine social and a significant range of work demands relating to the following themes: social and cultural pluralism; national and economic development; science; technical and scientific development; religion and popular culture; and internationalisation.

Students should have a vocabulary of about 6,000 words by the end of the subject, the ability to vary their language appropriately in accordance with a limited range of social and work situations, be able to recognise and manipulate a choice of vocabulary and grammatical patterns on a limited level and to convey certain points of view. This subject prepares students to discuss a range of social topics and limited range of work topics, to present arguments or points of view, and to frame these in a style appropriate to the social, cultural and interpersonal factors present. Students should also be able to understand articles and documents on familiar topics and write short texts, such as letters, descriptions and simple explanations.

**971414/5, 972414/5, 973414/5,  
974414/5**

### **French Language and Culture**

The French language programs offered through the Institute for International Studies are those taught at the University of Sydney and Macquarie University. Both universities teach the language at various levels, accommodating different levels of proficiency. The French subjects develop communicative skills in listening, speaking, reading and writing, and introduce students to literary texts. Students also learn about French culture and contemporary society.

**971424/5, 972424/5, 973424/5,  
974424/5**

### **German Language and Culture**

The German language programs offered through the Institute for International Studies are those taught at the University of Sydney and Macquarie University. Both universities teach the language at various levels, accommodating different levels of proficiency. The German subjects develop communicative skills in listening, speaking, reading and writing, and introduce students to literary

texts. Students also learn about German culture and contemporary society.

**971434/5, 972434/5, 973434/5,  
974434/5**

### **Italian Language and Culture**

The Italian language programs offered through the Institute for International Studies are those taught at the University of Sydney and Macquarie University. Both universities teach the language at various levels, accommodating different levels of proficiency. The Italian subjects develop communicative skills in listening, speaking, reading and writing, and introduce students to literary texts. Students also learn about Italian culture and contemporary society.

**971501, 972501, 973501, 974501**

### **Spanish Language and Culture 1**

*8cp; 1st semester, 6hpw; prerequisite: nil*

Spanish 1 is the first in a series of four units designed to provide students who have no prior knowledge of the Spanish language with basic survival skills in language and culture, and the ability to undertake In-country Study in Latin America or Spain.

By the end of the subject, students would be expected to have achieved 'elementary proficiency' and be able to satisfy immediate communication needs using expressions and phrases they have learnt that are required in basic social interaction. The program allows for the development of listening, speaking, reading and writing skills, and an understanding of the socio-cultural contexts in which the language is used. Students gain, in particular, an awareness of the background of Hispanic countries. Students also develop strategies for predicting the meaning of new expressions and anticipating ways of expressing new meanings.

Spanish 1 consists of 78 hours of classroom instruction. The approach adopted is 'communicative' and provides students with many opportunities to interact and use the language in various social and cultural contexts. Audiovisual equipment and computers will be used to facilitate learning.

### **Spanish Language and Culture 2**

*8cp; 2nd semester, 6hpw; prerequisite: Spanish 1*

Spanish 2 is the second in a series of four units designed to provide students who have no prior knowledge of the Spanish language with basic survival skills in language and culture,

and the ability to undertake In-country Study in Latin America or Spain.

By the end of the subject, students would be expected to have achieved 'minimum survival proficiency' in speaking, listening, reading and writing, and be able to satisfy immediate communication needs and minimum courtesy requirements in basic social interactions. Students will also develop an understanding of the socio-cultural contexts in which the language is used and further communication strategies.

Spanish 2 consists of 78 hours of classroom instruction. The approach adopted is 'communicative' and provides many opportunities for the students to interact and use the language in various social and cultural contexts. Audiovisual equipment and computers will be used to facilitate learning.

### **Spanish Language and Culture 3**

*8cp; 1st semester, 6hpw; prerequisite: Spanish 2 or HSC Spanish*

Spanish 3 is the third in a series of four units for students with no prior knowledge of the Spanish language, or first in a series of four units for students who have successfully completed HSC-level Spanish or its equivalent. It provides students with basic survival skills in language and culture, and the ability to undertake In-country Study in Latin America or Spain.

By the end of the subject, students would be expected to have achieved a communicative competence in speaking, listening, reading and writing skills in order to be able to satisfy all 'survival' needs and limited social needs. They would also be expected to have developed an awareness of the various social and cultural contexts in which the language is used. In this subject, students develop the ability to understand the general content of magazine and newspaper articles.

Spanish 3 consists of 78 hours of classroom instruction. The approach adopted is 'communicative' and provides many opportunities for the students to interact and use the language in various social and cultural contexts. Audiovisual equipment and computers will be used to facilitate learning.

### **Spanish Language and Culture 4**

*8cp; 2nd semester, 6hpw; prerequisite: Spanish 3*

Spanish 4 is the fourth in a series of four units for students with no prior knowledge of the Spanish language, or second in a series of four

units for students who have successfully completed Spanish 3 and HSC-level Spanish or its equivalent. It provides students with basic survival skills in language and culture, and the ability to undertake In-country Study in Latin America or Spain.

By the end of the subject, students would be expected to have begun to develop the communication skills required to satisfy limited routine social and work demands. They would also be expected to have developed an awareness of the various social and cultural contexts in which the language is used. In this subject, students learn to express opinions, discuss education, entertainment and travel, and develop the language skills and background knowledge required to find accommodation.

Spanish 4 consist of 78 hours of classroom instruction. The approach adopted is 'communicative' and provides many opportunities for the students to interact and use the language in various social and cultural contexts. Audiovisual equipment and computers will be used to facilitate learning.

### **Spanish Language and Culture 5**

*8cp; 1st semester, 6hpw; prerequisite: Spanish 4*

Spanish 5 is the third in a series of four units designed to provide students who have successfully completed Spanish 4 and HSC-level Spanish or its equivalent with the ability to consolidate and extend their knowledge during a period of In-country Study in Latin America or Spain.

By the end of the subject, students would be expected to have achieved the communicative competence in speaking, listening, reading and writing to be able to satisfy routine social demands and limited work requirements. They would have developed an awareness of the various social and cultural contexts in which the language is used. Students learn to communicate in Spanish to compare lifestyles, university life and education, and practise interview techniques in preparation for In-country Study.

Spanish 5 consists of 78 hours of classroom instruction. The approach adopted is 'communicative' and provides many opportunities for the students to interact and use the language in various social and cultural

contexts. There are discussions and debates on set topics. Audiovisual equipment and computers will be used to facilitate learning.

### **Spanish Language and Culture 6**

*8cp; 2nd semester, 6hpw; prerequisite: Spanish 5*

Spanish 6 is the fourth in a series of four units designed to provide students who have successfully completed Spanish 5 and HSC-level Spanish or its equivalent with the ability to consolidate and extend their knowledge during a period of In-country Study in Latin America or Spain.

By the end of the subject, students would be expected to be able to speak the language with sufficient accuracy to participate in limited formal and informal conversations on practical and social topics. Students would also be expected to be able to read and write with sufficient accuracy to meet a limited range of social and work needs. Language focuses on topics such as the economy, class and social stratification, gender roles, religion and beliefs, literature, and the arts.

Spanish 6 consists of 78 hours of classroom instruction. The approach adopted is 'communicative' and provides many opportunities for the students to interact and use the language in various social and cultural contexts. There are discussions and debates on set topics. Audiovisual equipment and computers will be used to facilitate learning.

## **971710, 972710, 973710, 974710**

### **Greek**

Greek is offered to UTS students through arrangements with other universities in Sydney. Students are placed in classes appropriate to their level of competence. The program focuses on furthering writing and oral skills in contemporary Greek and learning about literature, society and culture.

## **971734, 972734, 973734, 974734**

### **Russian**

Russian is offered to UTS students through an arrangement with Macquarie University. Students are placed in classes appropriate to their level of competence. The aim of the Russian language program is to give students a good working knowledge of modern written

and spoken Russian and to enable them to express themselves in the language correctly and with reasonable facility.

**971744, 972744, 973744, 974744**

**Croatian**

Croatian language is offered to UTS students through an arrangement with Macquarie University. Students are placed in classes appropriate to their level of competence with particular emphasis in furthering pronunciation and writing skills and learning about the history of the Croatian language.

**971754, 972754, 973754, 974754**

**Slovenian**

Slovenian is offered to UTS students through an arrangement with Macquarie University. Students are placed in classes appropriate to their level of competence. The aim of the Slovenian language program is to provide students with a sound knowledge of the language to enable them to communicate effectively, with particular emphasis placed on broadening their vocabulary and grammar.

**971764, 972764, 973764, 974764**

**Polish**

Polish is offered to UTS students through an arrangement with Macquarie University. Students are placed in classes appropriate to their level of competence. The Polish language program allows students to improve their linguistic competence through practice in speaking and writing skills while consolidating their previous knowledge of grammar.

**971774, 972774, 973774, 974774**

**Ukrainian**

Ukrainian is offered to UTS students through an arrangement with Macquarie University. Combined degree students with a sound working knowledge of the language are admitted to study Ukrainian. Students are placed in classes appropriate to their level of competence. The Ukrainian language program allows students to improve their reading, writing and oral skills with particular emphasis placed on the study of grammar and syntax.

**976101**

**Chinese East Asia**

*8cp; 2nd semester, 4hpw*

South China – Hong Kong, Taiwan and the Southern Chinese provinces of Fujian and Guangdong – is a region of global importance. It is a dynamo of economic growth for the East Asia region that has grown out of the economic integration of Hong Kong, Taiwan and South China, and is now expanding to include East China. Yet its constituent parts have developed separately in different and often inimical political systems. As a result of all of these factors, South China is likely to be of increasing importance strategically, economically and politically. This subject examines the development of Hong Kong, Taiwan and South China and their interaction. It is an introductory subject that requires no prior knowledge of the region or of any Chinese language.

**976111**

**Contemporary China**

*8cp; 2nd semester, 4hpw*

This subject examines the contours and dynamics of social, political and economic change in the People's Republic of China since the death of Mao Zedong and the start of the reform era. A central theme is the emerging relationship between state and society in a state socialist system in the process of change and reform. It is an introductory subject that requires no prior knowledge of the People's Republic of China or of any Chinese language.

**976211**

**Contemporary Japan**

*8cp; 2nd semester, 4hpw*

This subject provides an introduction to the dynamics of political, social and economic systems in Modern Japan. Central themes are the causes and consequences of social change and continuity in the context of Japan's emergence as an economic superpower. In the process, it offers a general introduction to Japan's culture. This subject requires no prior knowledge of Japan or of Japanese.

**976301****Contemporary South-East Asia***8cp; 2nd semester, 4hpw*

This subject provides an introduction to the countries of Indonesia, Malaysia and Thailand. The themes of modernity and identity will be examined at a political-economic level and also at the individual level. Issues which will be explored include migration patterns in the context of regional interrelationships; increasing urbanisation; legacies of colonialism; the commodification of culture and the growing impact of tourism; new creative forms in visual literary and performing arts; the beliefs about and behaviour of women in the region; and ways in which religion and social practice intersect.

**976401****Contemporary Europe***8cp; 2nd semester, 5hpw*

This unit is an introduction and an overview laying the groundwork for the study of contemporary Europe. It surveys present-day European Union institutions and sociopolitical developments and provides a comparative study of political and social developments in the countries of Western and Eastern Europe. It aims to provide students with an understanding of the historical background of the present-day Europe and enable them to identify major contemporary policy issues in this region of the world.

**976501****Contemporary Latin America***8cp; 2nd semester, 4hpw*

Latin America has been a crucible for social, political and economic change in the 19th and 20th centuries. Intense struggles for nationhood, democracy, economic modernisation, and secularisation, have all resonated in the countries of Latin America. During the middle of the 20th century Latin America's primary concerns were focused on national self-determination, inward industrialisation, and populist authoritarian efforts to legitimise elite rule. In the late 20th century the emphasis has shifted towards economic growth, internationalisation, and pressures to improve the capacity and accountability of governments. The unit aims to prepare students with the historical background, cultural awareness and analytic skills to interpret everyday social, political and

economic reality during their period of In-country study. The subject requires no prior knowledge of Latin America or Spanish.

**977xxx****In-country Study 1***24cp; prerequisite: completion of 4 semesters of study in the International Studies program*

As part of the International Studies combined degrees, students spend two semesters of In-country Study at a university or institution of higher education overseas. This is determined by the student's International Studies major.

The following majors are available in the International Studies program: Argentina, Australia and the Asia-Pacific Region, Chile, China, Croatia, France, Germany, Greece, Indonesia, Italy, Japan, Latin America, Malaysia, Mexico, Poland, Russia, Slovenia, South China, South-East Asia, Spain, Taiwan, Thailand and Ukraine.

**978xxx****In-country Study 2***24cp; prerequisite: completion of 4 semesters of study in the International Studies program*

As part of the International Studies combined degrees, students spend two semesters of In-country Study at a university or institution of higher education overseas. This is determined by the student's International Studies major.

The following majors are available in the International Studies program: Argentina, Australia and the Asia-Pacific Region, Chile, China, Croatia, France, Germany, Greece, Indonesia, Italy, Japan, Latin America, Malaysia, Mexico, Poland, Russia, Slovenia, South China, South-East Asia, Spain, Taiwan, Thailand and Ukraine.

# ***Numerical list of subjects***

The following table indicates the number and name of each subject, the semester or semesters in which it is offered (these are subject to change), the credit-point value, the number of contact hours, and the prerequisites and corequisites (indicated by *c*). The letters A and S refer to Autumn and Spring semesters, respectively, and Y is used for a year-long subject. As a general guide, four contact hours suggests three hours of lectures and one tutorial hour per week, and six contact hours suggests a further two hours of laboratory work per week.

Subject number	Subject name	Semester offered	CP	HPW	Prerequisites
015110	Aboriginal Cultures and Philosophies		8	3	Nil
22105	Accounting A	A,S	4	3	Nil
25110	Microeconomics	A,S	4	3	Nil
25209	Macroeconomics	A,S	4	3	25110
25210	Microeconomic Theory and Policy	A,S	6	4	25110
25308	Financial Markets	A,S	4	3	Nil
25314	Business Finance	A,S	4	3	22105, 35151, 25308 <i>c</i>
25421	International Financial Management	S	6	4	25308, 25314
25606	Financial Time Series Analysis	S	6	4	35232, 35353
25620	Derivative Securities	A	6	4	25906
25621	Financing Decisions and Capital Market Theory	A	6	4	25905
25905	Capital Budgeting and Valuation (Honours)	S	6	4	25308, 25314
25906	Investment Analysis (Honours)	S	6	4	25308, 25314
25907	Theory of Financial Decision Making	A	4	3	By consent
25908	Derivative Security Pricing	S	4	3	By consent
25909	Advanced Corporate Finance	S	4	3	By consent
25910	Thesis	Y	12		By consent
33401	Introductory Mathematical Methods	A	6	3	Nil
35100	Mathematical Practice	A,S	3	3	Nil
35101	Mathematics 1	A,S	6	6	Nil
35102	Mathematics 2	A,S	6	6	35101
35106	Mathematics in Sport	Summer	6	6	Nil
35111	Discrete Mathematics	A,S	3	3	Nil
35151	Statistics 1	A,S	6	6	Nil
35170	Introduction to Computing	A,S	6	7	Nil
35171	Computing 1	S	6	7	35170, 35111 <i>c</i>
35205	History of Mathematics	S	6	4	Nil
35212	Linear Algebra	A,S	6	4	35101
35231	Differential Equations	A,S	6	4	35102
35232	Advanced Calculus	A,S	6	4	35102
35241	Optimisation 1	A,S	6	4	35212, 35232
35252	Statistics 2	A,S	6	4	35102, 35151
35254	Health Statistics	A	6	4	35151
35272	Computing 2	S	6	6	35111, 35171
35274	Computing Seminar A	A or S	3	2	See subject description

Subject number	Subject name	Semester offered	CP	HPW	Prerequisites
35275	Computing Seminar B	A or S	3	2	See subject description
35281	Numerical Analysis 1	A,S	6	4	35170, 35231 <i>c</i>
35292-6	Project	A,S	2-6	1-4	By arrangement
35313	Pure Mathematics 3A	A	6	4	35231, 35232
35314	Pure Mathematics 3B	S	6	4	35111
35321	Analysis 1	A,S	6	4	35102, 35212
35322	Analysis 2	S	6	4	35321
35333	Applied Mathematics 3A	A	6	4	35232, 35335 <i>c</i>
35334	Applied Mathematics 3B	S	6	4	35333, 35335
35335	Mathematical Methods	A	6	4	35231
35340	Operations Research Practice	S	6	4	35241, 35252
35342	Optimisation 2	A	6	4	35241
35344	Network Optimisation	S	6	4	35241
35353	Regression Analysis	A	6	4	35252
35354	Statistical Inference	A	6	4	35252
35355	Quality Control	S	6	4	35252
35356	Design and Analysis of Experiments	S	6	4	35212, 35252
35361	Probability and Stochastic Processes	A,S	6	4	35252
35363	Simulation Modelling	A,S	6	4	35170, 35361 <i>c</i>
35373	Computing 3	A	6	4	35272
35376	Advanced Topics in Computing A	A	6	4	See subject description
35377	Advanced Topics in Computing B	S	6	4	See subject description
35378	Computing Seminar C	A or S	3	2	See subject description
35379	Computing Seminar D	A or S	3	2	See subject description
35382	Numerical Analysis 2	S	6	4	35281
35384	Financial Modelling	A	6	4	35102, 35151
35391	Seminar (Mathematics)	A or S	6	4	By arrangement
35392	Seminar (Operations Research)	A or S	6	4	By arrangement
35393	Seminar (Statistics)	A or S	6	4	By arrangement
35394	Seminar (Computing)	A or S	6	4	By arrangement
35418	Analytic Number Theory	A	4	3	35314, 35232
35419	Advanced Algebra	A	4	3	35314
35427	Functional Analysis	S	4	3	35322
35428	Convexity and Optimisation	A	4	3	35322
35436	Advanced Mathematical Methods	S	4	3	35334
35437	Partial Differential Equations	A	4	3	35335
35438	Nonlinear Dynamical Systems	A	4	3	35231, 35321
35443	Advanced Mathematical Programming	S	4	3	35342
35446	Scheduling Theory	S	4	3	35342, 35447
35447	Discrete Optimisation	A	4	3	35111, 35342
35448	Dynamic Optimisation	A	4	3	35241, 35361, 35447 <i>c</i>
35456	Nonlinear Statistical Models	S	4	3	35353
35457	Multivariate Statistics	A	4	3	35353
35458	Loglinear Modelling	S	4	3	35353
35459	Linear Models and Experimental Design	S	4	3	35353, 35457, 35356
35466	Advanced Stochastic Processes	A	4	3	35322, 35361



Subject number	Subject name	Semester offered	CP	HPW	Prerequisites
35467	Time Series Analysis	A	4	3	35361
35469	Statistical Consulting	S	4	3	See subject description
35485	Advanced Financial Modelling	A	4	3	35340
35486	Optimal Control 1	A	4	3	35231, 35232
35487	Optimal Control 2	S	4	3	35466, 35486
35491	Honours Seminar A	A or S	4	3	By consent
35492	Honours Seminar B	A or S	4	3	By consent
35496	Thesis Seminar A	A	4	3	By consent
35497	Thesis Seminar B	S	4	3	By consent
35498	Thesis (Honours)	Y	16		By consent
35545	Further Methods in Operations Research	A	6	4	35151, 35342
35549	Case Studies in Management Science	S	6	4	35340, 35342, 35363
35594	Project	S	8		By arrangement
35596	Project	Y	12		By arrangement
35599	Report	Y	12		By consent
50140	Modernisation and Social Change	A,S	8	4	Nil
54230	Aboriginal Social and Political History	–	8	3	Nil
54231	Aboriginal People and the Media	–	8	3	015110, 54230
54330	The Politics of Aboriginal History	–	8	3	See subject description
54331	Aboriginal Forms of Discourse	–	8	3	See subject description
79202	Business Law	A,S	4	3	Nil
97x111	Chinese 1–10	A or S	8		See subject descriptions
97x121	Cantonese A1–A4, B1–B2	A or S	8		See subject descriptions
97x211	Japanese 1–6	A or S	8		See subject descriptions
97x311	Indonesian 1–6	A or S	8		See subject descriptions
97x320	Thai Language and Culture		8		See subject descriptions
97x331	Malaysian 1–6	A or S	8		See subject descriptions
97x414/5	French		8		See subject descriptions
97x424/5	German		8		See subject descriptions
97x434/5	Italian		8		See subject descriptions
97x501	Spanish 1–6	A or S	8		See subject descriptions
97x710	Greek		8		See subject descriptions
97x734	Russian		8		See subject descriptions
97x744	Croatian		8		See subject descriptions
97x754	Slovenian		8		See subject descriptions
97x764	Polish		8		See subject descriptions
97x774	Ukrainian		8		See subject descriptions
976101	Chinese East Asia	S	8		Nil
976111	Contemporary China	S	8		Nil
976211	Contemporary Japan	S	8		Nil
976301	Contemporary South-East Asia	S	8		Nil
976401	Contemporary Europe	S	8		Nil
976501	Contemporary Latin America	S	8		Nil
977xxx	In-country Study 1		24		See subject descriptions
978xxx	In-country Study 2		24		See subject descriptions

Note: In the case of International Studies subjects, x indicates one of four levels of study.

# ***Alphabetical list of subjects***

Aboriginal Cultures and Philosophies	015110	Financial Markets	25308
Aboriginal Forms of Discourse	54331	Financial Modelling	35384
Aboriginal People and the Media	54231	Financial Time Series Analysis	25606
Aboriginal Social and Political History	54230	Financing Decisions and Capital Market Theory	25621
Accounting A	22105	French Language and Culture 1–4	97x414/5
Advanced Algebra	35419	Functional Analysis	35427
Advanced Calculus	35232	Further Methods in Operations Research	35545
Advanced Corporate Finance	25909	German Language and Culture 1–4	97x424/5
Advanced Financial Modelling	35485	Greek 1–4	97x710
Advanced Mathematical Methods	35436	Health Statistics	35254
Advanced Mathematical Programming	35443	History of Mathematics	35205
Advanced Stochastic Processes	35466	Honours Seminar A	35491
Advanced Topics in Computing A	35376	Honours Seminar B	35492
Advanced Topics in Computing B	35377	In-country Study 1	977xxx
Analysis 1	35321	In-country Study 2	978xxx
Analysis 2	35322	Indonesian Language and Culture 1–4	97x311
Analytic Number Theory	35418	Information Systems	31414
Applied Mathematics 3A	35333	International Financial Management	25421
Applied Mathematics 3B	35334	Introduction to Computing	35170
Business Finance	25314	Introductory Mathematical Methods	33401
Business Law	79202	Investment Analysis (Honours)	25906
Cantonese Language and Culture A1–A4, B1–B2	97x121	Italian Language and Culture 1–4	97x434/5
Capital Budgeting and Valuation (Honours)	25905	Japanese Language and Culture 1–4	97x211
Case Studies in Management Science	35549	Linear Algebra	35212
Chinese Language and Culture 1–4	97x111	Linear Models and Experimental Design	35459
Chinese East Asia	976101	Loglinear Modelling	35458
Computing 1	35171	Macroeconomics	25209
Computing 2	35272	Malaysian Language and Culture 1–4	97x331
Computing 3	35373	Mathematical Methods	35335
Computing Seminar A	35274	Mathematical Practice	35100
Computing Seminar B	35275	Mathematics 1	35101
Computing Seminar C	35378	Mathematics 2	35102
Computing Seminar D	35379	Mathematics in Sport	35106
Contemporary China	976111	Microeconomic Theory and Policy	25210
Contemporary Japan	976211	Microeconomics	25110
Contemporary Latin America	976501	Modernisation and Social Change	50140
Contemporary South-East Asia	976301	Multivariate Statistics	35457
Contemporary Europe	976401	Network Optimisation	35344
Convexity and Optimisation	35428	Nonlinear Dynamical Systems	35438
Croatian 1–4	97x744	Nonlinear Statistical Models	35456
Derivative Securities	25620	Numerical Analysis 1	35281
Derivative Security Pricing	25908	Numerical Analysis 2	35382
Design and Analysis of Experiments	35356	Operations Research Practice	35340
Differential Equations	35231	Optimal Control 1	35486
Discrete Mathematics	35111	Optimal Control 2	35487
Discrete Optimisation	35447	Optimisation 1	35241
Dynamic Optimisation	35448	Optimisation 2	35342

## 82 SCHOOL OF MATHEMATICAL SCIENCES

Partial Differential Equations	35437	Simulation Modelling	35363
Polish 1-4	97x764	Slovenian 1-4	97x754
Politics of Aboriginal History, The	54330	Spanish Language and Culture 1-4	97x501
Probability and Stochastic Processes	35361	Statistical Consulting	35469
Project	35292-6	Statistical Inference	35354
Project	35592-6	Statistics 1	35151
Pure Mathematics 3A	35313	Statistics 2	35252
Pure Mathematics 3B	35314	Thai 1-4	97x320
Quality Control	35355	Theory of Financial Decision Making	25907
Regression Analysis	35353	Thesis	25910
Report	35599	Thesis (Honours)	35498
Russian 1-4	97x734	Thesis Seminar A	35496
Scheduling Theory	35446	Thesis Seminar B	35497
Seminar (Computing)	35394	Time Series Analysis	35467
Seminar (Mathematics)	35391	Ukrainian 1-4	97x774
Seminar (Operations Research)	35392		
Seminar (Statistics)	35393		

# School of Computing Sciences

The School offers the following courses:

## Undergraduate courses

Bachelor of Science in Computing Science  
 Bachelor of Information Technology  
 Bachelor of Science in Computing Science/  
 Bachelor of Arts in International Studies  
 Bachelor of Science in Computing Science/  
 Bachelor of Laws  
 Bachelor of Business/Bachelor of Science in  
 Computing Science  
 Bachelor of Science (Honours) in Computing  
 Science  
 Bachelor of Computing  
 Bachelor of Computing/Bachelor of Arts in  
 International Studies

## Postgraduate courses

### Research degrees

Doctor of Philosophy  
 Master of Science

### Coursework degrees

Master of Science in Computing

### Management Development Program

Master of Business in Information Technology  
 Management  
 Graduate Diploma in Information Technology  
 Management  
 Graduate Certificate in Information Technology  
 Management

### Interactive Multimedia

Master of Interactive Multimedia  
 Graduate Diploma in Interactive Multimedia  
 Graduate Certificate in Interactive Multimedia

### Internetworking

Master of Science in Internetworking  
 Graduate Diploma in Internetworking  
 Graduate Certificate in Internetworking

### Graduate Program

Graduate Diploma in Information Technology  
 Graduate Certificate in Information Technology  
 Graduate Certificate in Human-Computer  
 Interaction

## Academic advisers for 1998

Academic advisers in the School of Computing Sciences are located in Building 4, City campus (Broadway).

For calls made from outside the University, all extension numbers should be prefixed with 9514.

	Ext	Room
<b>Undergraduate courses</b>		
<i>Director, Undergraduate Studies</i>		
Dr Bruce Howarth	1859	530
<i>Bachelor of Science in Computing Science</i>		
Mr John Colville	1854	524
Mr Chris S Johnson	1834	360
Mr Chris W Johnson	1855	522
<i>Projects Coordinator</i>		
Mr John Tu	1856	523
<i>Bachelor of Information Technology</i>		
Mr Jim Underwood	1831	356
<i>Academic Liaison Officer (Special conditions, disability)</i>		
Dr Bruce Howarth	1859	530
<i>Electives Coordinator</i>		
Mr John Tu	1856	523
<b>Postgraduate courses</b>		
<i>All Graduate Certificates</i>		
Mr Peter Bebbington	1828	353
<i>Graduate Diploma in Information Technology</i>		
Mr Peter Bebbington	1828	353
<i>Master of Business in Information Technology Management and articulated courses</i>		
Mr David Wilson	1832	354
<i>Master of Interactive Multimedia and articulated courses</i>		
Dr Ross Todd	2722	2/7059
<i>Master of Science in Internetworking and articulated courses</i>		
Mr Ury Szewcow	1862	534
<i>Master of Science in Computing and Research degrees</i>		
Professor John Debenham	1837	437

Each adviser has specific consultation times. These are displayed on the Ground Floor noticeboards.

## Computing facilities

The School provides a number of network-connected laboratories used in both teaching and research. The network, together with a number of SUN UNIX servers, provides the application software required and a number of network services (www, ftp, email, news), which can be used to access resources and information throughout the University and the world. The School's URL is:  
<http://www.socs.uts.edu.au>

### General purpose laboratories

- UNIX laboratories – A combination of X-terminals and UNIX workstations provides students with access to the UNIX environment. They are used by many of the School's subjects.
- PC laboratories – A number of PC laboratories provide access to the PC/Windows-type environment. They are used by a number of programming and business application subjects.
- Access – General access to these laboratories is between the hours of 9.00 a.m. and 9.00 p.m., Monday to Friday, during semester. On some occasions, these laboratories are booked for different subjects and, during these booked times, students not enrolled in those subjects should vacate that laboratory. Timetable bookings will be located on the door of each laboratory, and are available on the School's Web site. After the first week of each semester examination period, and also during vacation periods, the laboratories are available only between 9.00 a.m. and 6.00 p.m.
- Extended hours of access to specialist laboratories can be gained through the use of the electronic security door system for which an E-card is required.

### Specific purpose laboratories

- Graphics laboratory – A number of Silicon Graphics UNIX computers provide practical graphics usage.
- Parallel processing – This laboratory provides transputer-based systems.
- Collaborative systems – A research laboratory involved in applying computer and communications technology to improving work practices.
- Distributed Systems Technology Centre and Multimedia Laboratory – A laboratory used for research into distributed systems,

in particular software protocols, network management, and interaction between multimedia and networks.

- Usability laboratory – A studio set-up for the testing, evaluation and analysis of interaction between computers and the human operators.
- Access – Access to these specific purpose laboratories will be arranged by the academic involved in a particular subject or research project.

### Remote access facility

The remote access facility provides modem access for students and staff through either terminal emulation or remote network connection using PPP. This allows users to access some of the School's computing systems and perform work from home.

### Help desk facility

The School's help desk – which is located in the Interface Room, Room 447, Building 4 – provides users with information on usage of the equipment, software and facilities, help with problems and a point of contact for reporting faults. The telephone number is 9514 1869.

## Information Technology Division (ITD) facilities

ITD is a University division that provides general computing facilities for all students at UTS. It provides a University-wide network interconnection, a number of large UNIX servers, and laboratories throughout the different campuses. The University provides access to Internet resources through its connection to AARNet.

### Laboratories

- ITD provides UNIX, PC and Macintosh laboratories throughout the University which are available for use by all students.
- Access to ITD's UNIX servers is available from all laboratories provided by ITD and the School of Computing Sciences.
- Buildings 2 and 5 laboratories – provide 24-hour, seven-day-per-week access.
- Building 4 UNIX and PC laboratories – provide 9.00 a.m. to 9.00 p.m. access, Monday to Friday only.

### Remote access facility

The remote access facility provides modem access by students and staff through terminal emulation or shell access (text only). This

allows users to access the University's computing systems and perform work from home.

### **Resource Centre facility**

ITD's Resource Centre and help desk – located on Level 9, Building 1 – provides assistance to the users of the academic computing facilities. During semester, the Resource Centre is open from 9.00 a.m. to 10.00 p.m., Monday to Friday. On weekends, and during semester breaks, it is open from 9.00 a.m. to 5.00 p.m. The help desk telephone number is 9514 2222.

## **PRIZES AND SCHOLARSHIPS**

The School of Computing Sciences awards the following prizes and scholarship on a yearly basis.

### **Asia Pacific Computer Consultants Tuition Scholarship**

This tuition scholarship, established in 1995 by Asia Pacific Computer Consultants, may be awarded annually to an able, needy, first-year, full-time student who is currently enrolled in the Bachelor of Science in Computing Science degree, and for whom this is the first year of tertiary study. The total value of the scholarship is \$10,000.

### **Atmosphera Prize for Interface Programming**

This prize was established in 1996 by Atmosphera Pty Ltd. It is awarded annually to the student enrolled in the Bachelor of Science in Computing Science degree who achieves the highest mark in the subject Operating Systems Facilities. The prize is a cash award of \$500.

### **CABS Information Technology Planning and Design Prize**

Established in 1985 by Computer Automated Business Systems Pty Ltd, this prize is awarded annually to the group of final-year students, enrolled in either the Bachelor of Science in Computing Science or the Bachelor of Information Technology, who obtain the highest mark in the subject Information Technology Planning and Design. The cash award of \$1,000 is shared among all students in the group.

### **Claude Lalanne-SITA Prize**

Established in 1996 by SITA, this prize is awarded annually to the student enrolled in the Bachelor of Science in Computing Science who achieves the best overall performance in the final year of the degree and who has completed the course within the minimum time. The prize is a cash award of \$1,000.

### **CSC Australia Prize for Communications**

Since 1971, Computer Sciences Corporation Australia Pty Ltd has made available an award in the interests of furthering education and knowledge in the field of telecommunications. The prize is awarded to the student enrolled in the Bachelor of Science in Computing Science who achieves the best combined performance in the subjects Systems Software and Networks, and Distributed Software Programming. The prize is a cash award of \$200.

### **Oracle Database Prize**

Established in 1994, the Oracle Database prize is awarded to the Bachelor of Science in Computing Science student who achieves the highest aggregate mark in the subjects Distributed Databases and Client/Server Computing, and Database Design. The prize has a cash value of \$400.

### **Software Quality Association (NSW) Prize for Software Quality Assurance**

This prize was established in 1997 by the Software Quality Association (NSW). It is awarded annually to the Bachelor of Science in Computing Science or the Bachelor of Information Technology student who achieves the highest mark in the subject, Software Quality Assurance. The prize has a cash value of \$400.

### **Westpac Information Systems Award**

This prize was established in 1987 by the Westpac Banking Corporation. It is awarded annually to the full-time Bachelor of Science in Computing Science student who develops the best IT strategic plan based on his or her Industrial Training experience. The prize has a cash value of \$1,000.

## School contacts

All staff of the School of Computing Sciences are located in Building 4, City campus (Broadway). For calls made from outside the University, all extension numbers should be prefixed with 9514. All email addresses should be suffixed with '@socs.uts.edu.au'.

Name	Ext	Room	Email
<i>Director, Graduate Education</i>			
Mr Peter Bebbington	1828	353	peterb
<i>Administrative Assistant</i>			
Ms Lyn Chamas	2154	335	lynette
Mr Jeff Clark	1827	355	clark
Mr John Colville	1854	524	colville
<i>Director, Postgraduate Studies</i>			
Professor John Debenham	1837	437	debenham
<i>Head of School</i>			
Associate Professor Jenny Edwards	1844	tba	jenny
Mr Jamal El-Den	1830	366	jamal
Dr George Feuerlicht	1835	363	jiri
Mr Nigel Hamilton	1833	358	nige
Mrs Judy Hammond	1822	359	judy
Professor Lynda Harvey	1687	tba	lynda
Professor Igor Hawryszkiewicz	1809	372	igorh
<i>Deputy Head of School</i>			
Associate Professor Tom Hintz	1865	548	hintz
<i>Director, Undergraduate Studies</i>			
Dr Bruce Howarth	1859	530	bruce
Professor John Hughes	1329	436	hughes
Associate Professor Barry Jay	1814	514	cbj
Mr Sanjay Jha	1858	520	sanjay
Mr Chris S Johnson	1834	360	chrisj
Mr Chris W Johnson	1855	522	chris
Mrs Elaine Lawrence	1861	533	elaine
Dr Brian Lederer	tba	tba	tba
<i>Executive Assistant</i>			
Dr Kim O'Toole	1808	367	kimo
Dr Tom Osborn	1852	519	osborn
Dr Sattiraju Prabhakar	1851	515	prabhakar
Mr Richard Raban	1829	365	richard
Dr Robert Rist	1849	516	rist
Dr Kylie Sayer	1836	364	kylie
Dr Kevin Suffern	1845	512	kevin
Mr Ury Szewcow	1862	534	ury
Mr John Tu	1856	523	vohao
Mr Jim Underwood	1831	356	jim
Dr Ron van der Meyden	1850	514	ron
<i>Director, Industry Liaison</i>			
Mrs Alice Watkins	1885	526	alicew
Mr David Wilson	1832	354	davidw
Mr Bernard Wong	1825	357	bernard
<i>Administrative Assistant</i>			
Ms Marie Woessner	1258	tba	marie
Interface Room	1869	447	

# Undergraduate courses

---

## Bachelor of Science in Computing Science

**Course code: MC02**

This course aims to provide a sound education in all aspects of computing for students who intend to make a career in the profession. It is intended that the course will provide a suitable background covering all aspects of information technology, short of the actual design and construction of hardware systems.

The course provides an in-depth study of computing science and its applications and, in addition, support subjects are included to enable graduates to fulfil an appropriate function in the sphere of business activity. It is intended that the formal studies will be treated in a manner that will encourage initiative. Not only will the course provide a suitable framework for a professional career, it will also form a basis from which postgraduate studies may begin.

The course consists of six academic semesters of full-time study or the equivalent in part-time attendance, and a period of Industrial Training. Holders of the degree are granted exemption from the Associate examinations of the Australian Computer Society.

### Grading of awards – pre-1998

Students are graded for awards by a two-stage process involving first qualifying and then grading students.

The subjects to be included in the grading process are the core subjects, excluding those normally taken during Stages 1 and 2 of the part-time course or the first year of the full-time course. All core subjects must be passed. Any of those subjects that have been failed and subsequently passed will be included with a raw mark of 50 per cent.

### Qualifying

#### Pass degree

A student who has accumulated 144 credit points and has an average raw mark of 50 per cent or greater will qualify for a Pass degree.

### Grading

#### Honours degree

The average raw marks required to achieve the Honours grades in 1995 and 1996 were:

First Class Honours: 75 per cent  
Second Class Honours: 68 per cent

The grading of qualifying students is carried out by the School's Examination Review Committee on an individual basis. The Committee is provided with the following information on each qualifier:

- any failures, including subject details and whether or not a failure was of a technical nature;
- the subject details and marks for all electives undertaken;
- the time taken to complete the course in terms of stages, excluding periods of leave of absence; and
- the average mark for each stage during the course.

### Grading of awards – post-1998

Students commencing the degree from 1998 onwards will no longer be awarded Honours just on the basis of marks in subjects taken in the degree. The BSc will now be awarded with Distinction, Credit or Pass using a similar system to that previously used for awarding Honours.

To gain Honours, students will have to enrol in a separate Honours program and reach an appropriate level in their studies. Full details of this program and its grading are given in the section of this handbook on Honours.



## Industrial Training

All students in the BSc in Computing Science are required to pass two Industrial Training subjects. The prerequisites for Industrial Training are noted in the 'Subject descriptions' section for the School of Computing Sciences in this handbook. Full-time students normally undertake Industrial Training after completing Year 2 of the course, part-time students after completing Year 4.

To gain credit for Industrial Training, students are required to obtain an approved, full-time job within the information industry. The duration of Industrial Training is a minimum of nine months for full-time students or 18 months for part-time students. During Industrial Training, students are required to behave in a professional manner, and to keep the School informed of the status of their employment at all times so that the School is able to assess their experience. Each year the School of Computing Sciences publishes an *Industrial Training Student Guide* (for full-time students) which sets out in detail what is required to pass the subject. Students will receive a copy of this Guide at the Industrial Training information session held in May each year.

Although the securing of suitable employment during Industrial Training is the student's responsibility, the School provides assistance to all Industrial Training students. Students who wish to benefit from the direct assistance of the School in finding an Industrial Training position should refer to the *Industrial Training Student Guide* for the procedure to be followed.

Students who wish to seek an Industrial Training position without the direct assistance of the School should first make an appointment to see the Industry Liaison Officer, who will provide a description of the requirements of an Industrial Training position. If a student finds employment, a second appointment must be made to see the Industry Liaison Officer to obtain certification that the employment is suitable for Industrial Training. Full-time Industrial Training students are assessed by members of the academic staff who normally visit students during the first semester of their employment.

In general, students find Industrial Training extremely beneficial in relating the final year of coursework to the practical needs of the information industry, and this experience can be cited when applying for graduate career positions.

## Exemptions

Exemptions may be granted on the basis of recent academic study (within the last three years) towards a degree. Students must be able to demonstrate that the knowledge is current. Exemption from core subjects may be granted where subjects successfully completed previously coincide with BSc subjects.

Students are expected to apply for exemptions, for which they believe they are eligible, at the commencement of their first year of study. Exemptions are usually processed by the School immediately following enrolment.

### Exemptions for holders of TAFE Associate Diplomas and Diplomas

Holders of the following TAFE Associate Diplomas who are admitted to the Bachelor of Science in Computing Science will be eligible for the following exemptions, provided the qualifications were gained within three years of the date of entry to UTS. (TAFE subjects are shown in italics.) Standard sets of exemptions also exist for the new TAFE Diplomas.

#### Associate Diploma of Business (Commercial Data Processing)

31414	Information Systems	6cp
2402C	<i>Systems Analysis and Design 1</i>	
2402D	<i>Computing 1</i>	
31417	Computing Practice	6cp
2402D	<i>Computing 1</i>	
2402A	<i>Programming Concepts</i>	
2402Y	<i>Computers in Business and Society</i>	
8559C	<i>Business Communication</i>	
31429	Procedural Programming	6cp
2402A	<i>Programming Concepts</i>	
2402J	<i>Programming Workshop</i>	
2402P	<i>Programming Option – C</i>	
22615	Accounting Information Systems	6cp
2402C	<i>Systems Analysis and Design 1</i>	

To obtain the exemption in 31417 Computing Practice, students must demonstrate knowledge of UNIX commands and utilities.

Unspecified CS/IS electives: 18cp

Total: 42cp

**Associate Diploma of Business  
(Microcomputer Systems)**

31414	Information Systems	6cp
8519K	Business Systems	
2403AG	Data Fundamentals	
31417	Computing Practice	6cp
2403A	Microcomputer System Usage	
2403AC	Single-User Operating Systems	
2403AD	Electronic Spreadsheets	
8559H	Business Communications Writing	

To obtain the exemption in 31417 Computing Practice, students must demonstrate knowledge of UNIX commands and utilities.

Unspecified electives: 18cp

Total: 30cp

**Associate Diploma of Engineering  
(Electronic Engineering)**

31416	Computer Systems Architecture	6cp
2840BC	Computer Principles	
2840CN	Digital Computers 1	
2840CP	Digital Computers 2	
2840AL	Electronic Communications Systems	
2840BB	Computer Data Communications 1	

Unspecified electives: 24cp

Total: 30cp

**Elective exemptions**

Exemption from electives may only be granted on the basis of recent academic study (within the last three years) towards a degree or TAFE award. Students must be able to demonstrate to the Subject Coordinators that their knowledge is current.

At the discretion of the Director, Undergraduate Studies, exemption from some electives may be granted where a student has successfully completed:

- specific computing elective subjects where either the subject was previously completed at UTS, or the subject is substantially the same as a UTS subject in content and level;
- subjects that correspond in content and level to some subjects in a formal UTS sub-major, provided that the remaining subjects in the sub-major are taken to a total of 24 credit points;

- subjects that correspond in content and level to some subjects in a coherent staged group of UTS subjects in another discipline, provided that the remaining subjects in the group are taken to a total of 24 credit points in the discipline; or
- a coherent staged group of elective subjects for which there is no equivalent at UTS.

**Pre-1989 course**

Students who commenced the BSc prior to 1989 should consult the Director, Undergraduate Studies, to determine their course program.

**Program for students who commenced before 1995**

**Recommended full-time program**

This program is included to assist pre-1995 students. **These subjects are no longer offered, and cannot be claimed for exemptions.**

**Year 1**

---

**Autumn semester**

31611	Information Systems	4cp
31613	Computer Systems Architecture 1	4cp
31614	Programming Principles	5cp
31615	Discrete Mathematics	4cp
31617	Accounting Fundamentals	4cp
51370	Human Communication	3cp

**Spring semester**

31621	Systems Analysis	4cp
31622	Commercial Programming Development	4cp
31623	Computer Systems Architecture 2	4cp
31624	Data Structures and Algorithms	4cp
31625	Software Engineering	4cp
31626	Probability and Statistics	4cp

**Year 2**

---

**Autumn semester**

31631	Database	4cp
31632	Communications and Networks	4cp
31633	Operating Systems	4cp
31636	Simulation and Modelling	4cp
	CS/IS Elective 1	4cp
	Elective 1	4cp

**Spring semester**

31641	Systems Design	4cp
31642	On-line Systems	4cp
31647	Management Control Systems	4cp
31648	Business Tools and Applications	4cp
	CS/IS Elective 2	4cp
	Elective 2	4cp

**Year 3****Autumn semester**

31696	Industrial Training	0cp
-------	---------------------	-----

**Spring semester**

31697	Industrial Training	0cp
-------	---------------------	-----

**Year 4****Autumn semester**

31653	Communications Software	4cp
31655	Theory of Computer Science	4cp
31658	Project Management	4cp
	CS/IS Elective 3	4cp
	Elective 3	4cp
	Elective 4	4cp

**Spring semester**

31662	Information Systems Case Study	5cp
31666	Performance Evaluation	4cp
31669	Social Implications of Computers	3cp
	CS/IS Elective 4	4cp
	Elective 5	4cp
	Elective 6	4cp

**Pre-1995 course electives information**

Electives provide the opportunity for students to include in their program some advanced computing subjects, subjects of personal interest which need not be related to computing, or subjects to form a sub-major in another discipline. A total of 40 credit points is allocated to elective subjects.

A student is required to take:

- a computing elective stream of 16 credit points. This may be chosen from Information Systems, Computer Science, or both. A strand taken predominantly from a single area is preferred over a collection of unrelated subjects;

*and*

- a further stream of 24 credit points which will be one of the following:

- (a) a formal sub-major of 24 credit points from a UTS faculty;

*or*

- (b) at the discretion of the Director, Undergraduate Studies, or the Electives Coordinator, a number of subjects from another UTS discipline or another institution, at least 20 credit points of which form a coherent staged group. A staged group is one where there is a pattern of prerequisites between the subjects that show progression of at least three levels. A coherent group is one in which all subjects are from the one area of knowledge. This may leave the student with four credit points to take a 'free' subject from any discipline. (Special arrangements may be made for the study of a foreign language at another university);

*or*

- (c) at least 16 credit points of electives from the School of Computing Sciences (in addition to the 16 compulsory School of Computing Sciences elective credit points referred to above). This choice will leave students with up to eight 'free' credit points to complete the 24 credit points of 'other' electives that are needed to complete the second part of the elective requirement.

For the purposes of determining completion of elective requirements, the School will award four credit points for every three hours of electives completed up until the end of 1992.

### Transferring to the post-1995 course

The programs that students should undertake, according to their year of commencement and attendance pattern, are shown in the table below:

#### Full-time

Commenced ↓	<b>1998</b>
<b>1995</b>	new 4F

#### Part-time

Commenced ↓	<b>1998</b>	<b>1999</b>	<b>2000</b>
<b>1993</b>	new 6P		
<b>1994</b>	new 5P	new 6P	
<b>1995</b>	new 4P	new 5P	new 6P

Students should note that from 1998, there will be changes to the credit points of some subjects.

### Approximate equivalents between pre-1995 and post-1995 BSc subjects

Post-1995	Pre-1995
22615 Accounting Information Systems	31617 Accounting Fundamentals
31414 Information Systems	31611 Information Systems 31621 Systems Analysis
31415 Principles of Software Development A	31614 Programming Principles
31416 Computer Systems Architecture	31613 Computer Systems Architecture 1 31623 Computer Systems Architecture 2
31417 Computing Practice	No equivalent
31424 Systems Modelling	31621 Systems Analysis 31641 Systems Design 31858 Object-oriented Analysis and Design
31425 Principles of Software Development B	31615 Discrete Mathematics 31625 Software Engineering
31428 Quantitative Modelling	31626 Probability and Statistics 31636 Simulation and Modelling
31429 Procedural Programming	31622 Commercial Programming 31624 Data Structures and Algorithms 31904 Systems Programming
31434 Database Design	31631 Database
31436 Systems Software and Networks	31632 Communications and Networks 31633 Operating Systems
31444 Systems Design and Development	31641 Systems Design 31642 On-line Systems
31454 Project Management and the Professional	31658 Project Management 31669 Social Implications of Computers
31455 Software Development Case Study	31655 Theory of Computer Science 31625 Software Engineering
31464 Information Technology Planning and Design	31662 Information Systems Case Study

## Program for students who commenced from 1995 onwards

Students should note that in 1998 and 1999 there will be some changes to credit points for 31454, 31455 and electives.

### Recommended full-time program

#### Year 1

##### Autumn semester

31414	Information Systems	6cp
31415	Principles of Software Development A	6cp
31416	Computer Systems Architecture	6cp
31417	Computing Practice	6cp

##### Spring semester

31424	Systems Modelling	6cp
31425	Principles of Software Development B	6cp
31428	Quantitative Modelling	6cp
31429	Procedural Programming	6cp

#### Year 2

##### Autumn semester

22615	Accounting Information Systems	6cp
31434	Database Design	6cp
31436	Systems Software and Networks Electives	8cp

##### Spring semester

31444	Systems Design and Development Electives	10cp
		6cp

#### Year 3

##### Autumn semester

31696	Industrial Training	0cp
-------	---------------------	-----

##### Spring semester

31697	Industrial Training	0cp
-------	---------------------	-----

#### Year 4

##### Autumn semester

31454	Project Management and the Professional	8cp
31455	Software Development Case Study Electives	5cp 12cp

##### Spring semester

31455	Software Development Case Study (cont.)	5cp
31464	Information Technology Planning and Design Electives	6cp 12cp

### Recommended part-time program

#### Year 1

##### Autumn semester

31416	Computer Systems Architecture	6cp
31417	Computing Practice	6cp

##### Spring semester

31414	Information Systems	6cp
31415	Principles of Software Development A	6cp

#### Year 2

##### Autumn semester

31425	Principles of Software Development B	6cp
31428	Quantitative Modelling	6cp

##### Spring semester

31424	Systems Modelling	6cp
31429	Procedural Programming	6cp

#### Year 3

##### Autumn semester

31434	Database Design Elective	6cp
		6cp

##### Spring semester

31436	Systems Software and Networks Elective	8cp
		6cp

#### Year 4

##### Autumn semester

31444	Systems Design and Development	10cp
-------	--------------------------------	------

##### Spring semester

22615	Accounting Information Systems Elective	6cp
		6cp

#### Year 5

##### Autumn semester

31455	Software Development Case Study Elective	5cp
		6cp
31698	Industrial Training	0cp

##### Spring semester

31455	Software Development Case Study (cont.) Elective	5cp
		6cp
31698	Industrial Training	0cp

#### Year 6

##### Autumn semester

31454	Project Management and the Professional Elective	8cp
		6cp
31699	Industrial Training	0cp

**Spring semester**

31464	Information Technology Planning and Design	6cp
	Elective	6cp
31699	Industrial Training	0cp

**Electives**

Students should refer to the Bachelor of Science in Computing Science prerequisite chart.

Students must do a minimum of 42 credit points of electives, of which 18 credit points must be taken from the School of Computing Sciences. The remaining elective credit points (minimum 24) may also be taken from the School of Computing Sciences. Alternatively, a student may opt to take a coherent staged group of subjects, normally a formally approved sub-major from another school or faculty. Typically, these are from the Faculties of Business, Engineering, Humanities and Social Sciences, Science, and the School of Mathematical Sciences.

Many subjects which are offered by other schools and faculties may contain material which is covered already in the Computing Science degree. Students who would like to take subjects from other parts of the University which are not part of sub-majors approved for Computing Sciences students (as listed in this handbook), should discuss their proposed subjects with the Electives Coordinator or an Academic Adviser. (It should be noted that the norm for electives is 42 credit points, but as subjects in other faculties have a variety of credit points, a student's total elective credit points may exceed 42.)

Students should be aware that they may enrol in subjects in another faculty, only if a class place is available. This applies particularly to the Faculties of Business, and Humanities and Social Sciences. This will change in 1999.

**Projects**

In lieu of one or two elective subjects, students may take one 6cp project, two 6cp projects, or one 12cp project over one or two semesters. In many cases, these projects may be completed over the Christmas or between-semester breaks, if desired. Please note that a **maximum** of 12 credit points may be taken as projects.

A list of projects nominated by various staff members may be viewed on the SUNs, by logging in as **projects** and following the instructions. Students should also complete a Project Registration form, available from the Projects Coordinator, who will answer any

queries. Students who have their own ideas for projects may approach relevant staff members to be their supervisors and must also see the Projects Coordinator for approval. Enrolment will not be allowed without an approved Project Registration form.

Students may not use work done in the normal course of duties as an Industrial Training student, or as a part-time student, as a project. Students may, however, do a project that is related to their work if it is done outside normal work hours. In this case, the student's work supervisor would probably become a joint supervisor of the project.

As a general guide, a student doing a 6cp project is expected to spend a **minimum** of 150 hours on the project.

**Sub-majors**

**University-wide sub-majors**

**Aboriginal Studies sub-major 24cp**

Telephone 9514 2057

The Faculties of Humanities and Social Sciences and Education offer a range of Aboriginal Studies subjects that may be taken as a sub-major, or as elective subjects, as appropriate, within any undergraduate course.

The sub-major provides Aboriginal and non-Aboriginal students with an opportunity to study subjects that are culturally appropriate to an understanding of Aboriginal culture, history and social/political structures. These initial studies serve as a basis for applying critical analysis skills to Aboriginal and non-Aboriginal perspectives on issues and trends which affect the cultural and social integrity of Aboriginal peoples. Consideration is also given to other indigenous people, including Torres Strait Islanders. The role of the media and written or spoken communication are the major focuses of these analyses.

015110	Aboriginal Cultures and Philosophies	8cp
54230	Aboriginal Social and Political History <i>plus at least one of</i>	8cp
54231	Aboriginal People and the Media	8cp
54330	The Politics of Aboriginal History	8cp
54331	Aboriginal Forms of Discourse	8cp

**Mathematical Sciences**

Contact person: J Hogg  
 Telephone 9514 2238; Room 1524, Building 1

**Operations Research sub-major (24cp)**

*Compulsory subjects*

33401	Introductory Mathematical Methods	6cp
35241	Optimisation 1	6cp
35340	Operations Research Practice	6cp
35344	Network Optimisation	6cp

**Statistics**

*Compulsory subjects*

33401	Introductory Mathematical Methods	6cp
35252	Statistics 2	6cp
35353	Regression Analysis	6cp
35361	Probability and Stochastic Processes	6cp

With the exception of the subject pair 33401 Introductory Mathematical Methods and 35241 Mathematical Programming 1, students are not permitted to take individual subjects from the School of Mathematical Sciences but must enrol for a sub-major.

**Humanities and Social Sciences**

The Faculty of Humanities and Social Sciences offers electives and elective sub-majors to students across the University. Information on the timetabling of subjects can be obtained by viewing the Electives timetable displayed outside the Faculty Student Centre in the corridors on Level 2 of Building 3; by reading the *Faculty of Humanities and Social Sciences Handbook* available for viewing in the Faculty Student Centre, or, by visiting or calling the Faculty Student Centre located on Level 2 of Building 3, telephone 9415 2300.

**Business**

The following sub-majors are offered to Computing Science students by the Faculty of Business. Students may undertake other sub-majors if they have the necessary prerequisites. Further information on these sub-majors can be obtained from the Student Liaison Unit, Faculty of Business, or by telephoning the relevant School as indicated.

*Students are advised to check the Faculty of Business timetable at the time of enrolment for any changes in subject numbers/names.*

**School of Accounting**

Telephone 9514 3560

**Financial Reporting (22cp)**

22205	Accounting B	4cp
22320	Accounting for Business Combinations	6cp
22420	Accounting Standards and Regulation	6cp
	<i>plus one of the following</i>	
22319	Issues in Financial Statement Analysis	6cp
22240	International Accounting	6cp
22206	Government Accounting	6cp
22610	Accounting for Insolvency	6cp

**Management Reporting (22cp)**

22205	Accounting B	4cp
22318	Contemporary Issues in Management Accounting	6cp
22321	Cost Management Systems	6cp
22421	Managerial Decisions and Control	6cp

**Small Business Accounting (22cp)**

22205	Accounting B	4cp
22566	Accounting for Small Business 1	6cp
22309	Accounting for Overseas Transactions	6cp
22567	Accounting for Small Business 2	6cp

Note: 22615 Accounting Information Systems will be accepted as the prerequisite subject for 22205 Accounting B.

These combinations have a value of 22 credit points. A sub-major must consist of a minimum of 24 credit points. It is suggested that students take the subject 31902 Auditing the Computer 4cp to complete the sub-major.

**School of Finance and Economics**

Telephone 9514 3633

**Economics (26cp)**

25209	Macroeconomics	4cp
25210	Microeconomic Theory and Policy	6cp
25303	Industry Economics	6cp
25110	Microeconomics	4cp
25309	Macroeconomic Theory and Policy	6cp

**School of Management**

Telephone 9514 3600

**Employment Relations (26cp)**

21125	International Business Environment	4cp
21130	Management and Organisations	4cp
21306	International Employment Relations	6cp
21407	Strategic Human Resource Management	6cp
31735	Information Systems and Organisation Development	6cp

**International Management (26cp)**

21125	International Business Environment	4cp
21130	Management and Organisations	4cp
21591	International Management	6cp
21531	Managing the International Organisation	6cp
31735	Information Systems and Organisation Development	6cp

**School of Marketing**

Telephone 9514 3422

**Introductory Advertising (28cp)**

24105	Marketing Principles	4cp
24202	Consumer Behaviour	6cp
24210	Advertising and Promotions Management	6cp
24309	Introductory Marketing Research	6cp
59330	Advertising Practice	6cp
	<i>or</i>	
59333	Advertising Strategies	6cp

**Introductory Marketing (28cp)**

24105	Marketing Principles	4cp
24202	Consumer Behaviour	6cp
24205	Business Marketing	6cp
24220	International Marketing	6cp
24309	Introductory Marketing Research	6cp

**Science**

**Physics (General) (24cp)**

This sub-major provides a grounding in general physics. It is of benefit to students contemplating a career in the programming of scientific and engineering problems. *Note: The subjects are under review.*

The minimum of 24 credit points may be made up as follows:

Subject number	Subject name	Semester offered	CP	Prerequisites
68711	Physics 1 S	A,S	8	
68721	Physics 2 S	A,S	8	Physics 1 S or permission
<i>plus two of the following</i>				
68731	Physics 3 S	A	4	Physics 2 S
68732	Applied Optics S	A	4	Physics 2 S
68743	Thermodynamics and Energy S	S	4	Physics 1 S
68741	Quantum Physics 1 S	S	4	Physics 3 S
68751	Nuclear Physics S	A	4	Quantum Physics 1 S



**BSc (Computing Science) prerequisite chart**

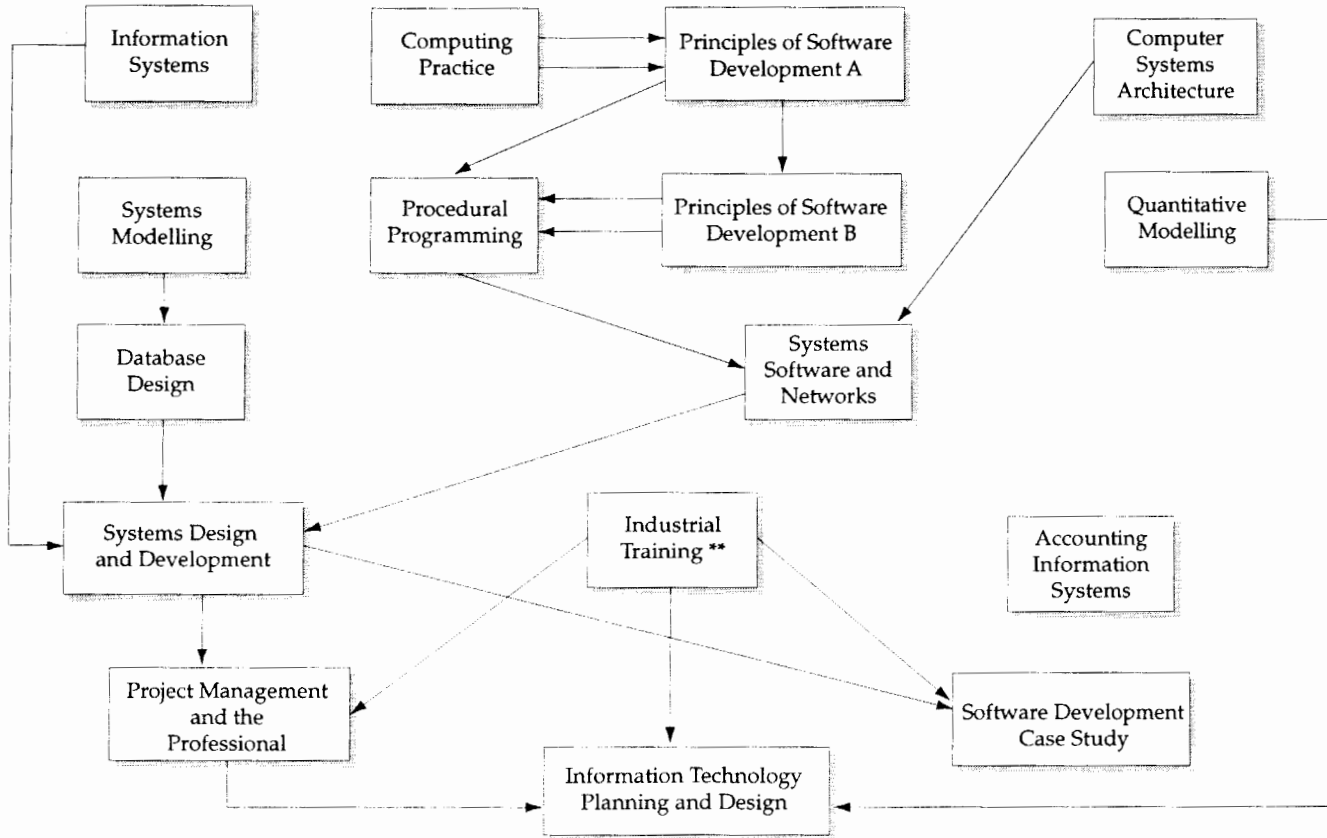

\*\* Prerequisites for Industrial Training are: Computing Practice, Computing Systems Architecture, Database Design, Information Systems, Principles of Software Development A, Procedural Programming, Systems Modelling and Systems Software and Networks.

———▶ Prerequisite or Corequisite

### Electronics (24cp)

This sub-major enables students to complement knowledge of software with a knowledge of hardware. It is useful to students contemplating a career in microprocessors or computer interfacing. *Note: The subjects are under review.*

The minimum of 24 credit points may be made up as follows:

Subject number	Subject name	Semester offered	CP	Prerequisites
68713	Physics for Electronics S	A,S	8	
68734	Electronics 1S	S, A	8	Physics 2 S
68744	Electronics 2S	S, S	4	Electronics 1S
68754	Microprocessors in Instrumentation S	S, A	4	Electronics 2 S

### Engineering

#### Electrical Computer Systems (21cp)

Contact: Undergraduate Programs Office, Faculty of Engineering

Telephone 9514 2666, Level 7, Building 2

The Faculty of Engineering offers an Electrical Computer Systems sub-major to Computing Science students. *Note: The subjects are under review.*

Subject number	Subject name	Semester offered	CP	Prerequisites
<i>Compulsory subjects</i>				
33401	Introductory Mathematical Methods	A	6	31415, 31428
45163	Real Time Software and Interfacing	A,S	3	45143
45364	Digital Systems	A,S	3	45143
45372	Computer Systems Analysis	S	3	45143, 33401
45382	Computer Systems Design	A	6	45372

This combination has a value of 21 credit points. A sub-major must consist of a minimum of 24 credit points. Students should undertake a four credit point elective subject offered by the School of Computing Sciences to complete the sub-major.

*Note:* One of the subjects in this sub-major is 33401 Introductory Mathematical Methods offered by the School of Mathematical Sciences.

### Electives from other universities

Students wishing to do electives outside the University **must** see the Electives Coordinator to discuss the proposal. Special approval must be sought well before the intended semester of study. Students may undertake subjects outside the University as electives **only** if no comparable subject is offered by the University.

## Bachelor of Information Technology

### Course code: MC03

This course is a cooperative education program in computer information systems and has been developed by the School of Computing Sciences in cooperation with a group of private and public sector employers. The course is of three years' duration and involves four semesters of full-time study at the University and two semesters of full-time study and practical experience in industry. The industry-based semesters are of 24 weeks' duration, and a 42-week academic year is the norm for the course.

Year	Semester 1	Semester 2
1	UTS	Industry
2	UTS	UTS
3	Industry	UTS

The program differs from existing cooperative education courses in that during the industry-based semesters, students will follow a structured program designed jointly by the University and the employer group, including formal coursework taught in industry. This coursework is assessed to University and business standards and familiarises students with business needs and requirements. During the industry-based semesters, students will be exposed to real problems within an environment quite different from that of the University. The resources of industry will be available to support the education of students.

The central curriculum of the course is information systems; this is supported by studies in management, accounting, finance and marketing as well as the necessary background subjects in computing science and programming. The active participation of industry practitioners in course design and course delivery will further ensure that graduates of the course are well equipped with skills that are relevant to present and future industry needs.

The two industry-based semesters will be spent with two different companies. Students are not employees of the company, and will not be obliged to find employment with a given company on completion of their studies. Nevertheless, students are encouraged to find employment within the group of sponsoring employers.

The number of students admitted each year will be limited by the number of sponsorship commitments secured from employers to a maximum of 50 places.

Each student admitted to the course will receive a scholarship for the duration of the course, subject to satisfactory performance and to certain conditions detailed further in this handbook. Each of the industry partners undertakes to sponsor a stated number of students, and contributes the full amount of their scholarship to a fund administered by the University.

The industry partners also provide the industry-based semester facilities for each of the students assigned to them.

Selection to the course is based on HSC results and on performance at an interview. Interviews are conducted by panels comprising representatives of the University and the industry group. Applicants will be assessed for their suitability to the industrial as well as the academic components of the course. The course is aimed primarily at school leavers and is limited to citizens and permanent residents of Australia. Mature age students are not normally admitted.

The Bachelor of Information Technology satisfies all of the requirements for associate membership of the Australian Computer Society, the industry's professional body.

### Grading of awards

The BInfTech is awarded as a Pass degree, a degree with Credit, or a degree with Distinction.

The grading is based on the Weighted Average Mark (WAM) of core subjects (with the exception of the industry-based semester Information Systems Practice and Contemporary Information Technology 2), and performance in the final industry-based semester.

The grading of qualifying students is carried out by the School's Examination Review Committee on an individual basis. This Committee takes account of input from the BInfTech Course Steering Committee. The Examination Review Committee is provided with the same information as that made available for the grading of BSc in Computing Science students, with one important addition: the overall assessment, by industry, of the final industry-based semester.

**Program for students who commenced from 1997 onwards**

**Year 1**

**Autumn semester – UTS**

31414	Information Systems	6cp
31415	Principles of Software Development A	6cp
31416	Computer Systems Architecture	6cp
31718	Contemporary Information Technology 1	6cp

**Spring semester – Industry**

31722	Commercial Programming	5cp
31770	Industry Project 1	5cp
31771	Business Requirements Analysis	5cp
31779	Applications of Information Technology 1	5cp

**Year 2**

**Autumn semester – UTS**

22615	Accounting Information Systems	6cp
31424	Systems Modelling	6cp
31434	Database Design	6cp
31436	Systems Software and Networks	8cp

**Spring semester – UTS**

31424	Systems Modelling	6cp
31444	Systems Design and Development	10cp
31443	Distributed Databases and Client/Server Computing	6cp
31735	Information Systems and Organisation Development Elective	6cp

**Year 3**

**Autumn semester – Industry**

31756	Project Management	5cp
31781	Business Systems Design	5cp
31789	Applications of Information Technology 2	5cp
31790	Industry Project 2	5cp

**Spring semester – UTS**

24105	Marketing Principles	4cp
31464	Information Technology Planning and Design	6cp
317xx	Business Processes and Information Technology Strategy	6cp
31769	Contemporary Information Technology 2 Elective	4cp

**Electives**

Electives may be taken from the Faculty of Law, Faculty of Business or the School of

Computing Sciences, subject to the approval of the Bachelor of Information Technology Coordinator.

**Special conditions**

There are special conditions relating to students enrolled in the Bachelor of Information Technology.

**Leave of absence** will not normally be granted to students, except under extraordinary circumstances and subject to satisfactory arrangements being possible. Likewise, **withdrawal** from the course and subsequent re-admission is not normally granted. Students are reminded that withdrawal without penalty from any course at the University is only possible up to the deadlines imposed by the University. After such deadlines, students will be expected to complete all assessment tasks for subjects in which they are enrolled.

**Variations to the approved program of study** for the Bachelor of Information Technology are restricted. No industry-based subject may be deleted from the program, except under extraordinary circumstances and at the discretion of the Course Steering Committee and the School of Computing Sciences. No industry-based subject may be taken during a University-based semester. The taking of additional subjects during an industry-based semester is seen as unusual and may only be done at the discretion of the Course Steering Committee and the School.

The School will not recommend probation for unsatisfactory academic performance. Instead, the School will recommend to the Faculty Board that a student be **excluded** under any of the following circumstances:

- a student fails any subject for the second time;
- a student gains less than 50 per cent of the credit points for which he or she is enrolled in that assessment period;
- a student fails any subject that is part of the program of an industry-based semester (there is provision for a supplementary examination to be taken in these subjects following a failure on the first attempt) or a student performs unsatisfactorily during an industry-based semester; or
- immediately prior to the commencement of an industry-based semester, a student has still to complete more than one subject in the normal program of the course to that stage.



Appeals against exclusion will be dealt with by the University's Appeals Committee (of the Academic Board), which will take into account the recommendation of the Course Steering Committee.

### Industry semesters

The dates of the industry-based semesters for 1998 are as follows:

Autumn semester (third-year students):  
Monday 19 January 1998–Friday 3 July 1998

Spring semester (first-year students):  
Monday 6 July 1998–Friday 18 December 1998

Students are expected to attend their assigned sponsoring company on a full-time basis throughout these periods. Students cannot expect any absences to be approved during the industry-based semesters.

### Personal details

Students must inform the University should their name or address change. BInfTech students **must** also inform Des Saunders, Industry Liaison Officer, of any changes to personal details. Students who wish to change the method of payment of the scholarship should contact the Salaries Office of the University's Financial Services Unit on 9514 2852.

### Scholarship

The scholarship will be paid at three different and increasing levels; all first-year students will start at Level 1. At the end of each year, all BInfTech students with satisfactory progress will move from their current level to the next level.

The levels for 1998 are as follows:

Level 1: \$10,000 per annum

Level 2: \$10,500 per annum

Level 3: \$11,000 per annum

The scholarship paid to BInfTech students has been ruled as tax exempt. The reference for the ruling by the Australian Tax Office is 6/SCHOLS/24, dated 29 February 1988.

## Bachelor of Science in Computing Science/ Bachelor of Arts in International Studies

**Course code: MC05**

This course combines the Bachelor of Science in Computing Science with the University's Bachelor of Arts in International Studies. Computing Science is integrated with a major in the language and culture of another country. The course is of six years' duration, and students spend the fourth year of study at a university overseas. The fifth and sixth years are completed part-time.

### Studies in Computing Sciences

The Computing Science component of the combined degree aims to provide a sound education in all aspects of computing for students who intend to follow a career in the profession. It is intended that the course will provide a suitable background covering all aspects of information technology, short of the actual design and construction of hardware systems.

For further information, see the course outline for the Bachelor of Science in Computing Science in this handbook.

### International Studies

The Bachelor of Arts in International Studies is designed to increase awareness and understanding of the non-English-speaking world.

Students take one of the following majors in the International Studies program: Argentina, Australia and the Asia-Pacific Region, Chile, China, Croatia, France, Germany, Greece, Indonesia, Italy, Japan, Latin America, Malaysia, Mexico, Poland, Russia, Slovenia, South China, South-East Asia, Spain, Taiwan, Thailand and Ukraine. They study an appropriate language and culture; learn about the contemporary society of their country of specialisation; and then spend an academic year of study at a university in their country of specialisation. In general, the International Studies program has no prior language requirement, except for entry to the Greece, Poland, Slovenia and Ukraine majors which is restricted to students who have a sound working knowledge of the language of their selected specialisation. Details of each major can be found in the *Institute for International Studies Handbook*.

The costs of tuition in host institutions overseas and travel between Sydney and the designated host institutions are borne by UTS. Visa fees are also paid by UTS and students are covered by the UTS Student Travel Insurance policy during their period of in-country study. The UTS medical service is available to students for medical examinations for visas, vaccinations and other country-specific health advice. Students must meet the costs of food, accommodation, transport and other maintenance during the period of in-country study. These costs vary from country to country and year to year. Before departure students will receive an In-country Study Guide which will provide, amongst other things, information on cost of living.

For native speakers, there may be opportunities for students to undertake Industrial Training during In-country Study.

### Course structure

The structure of the six-year course in Computing Science and International Studies is derived from the combination of the Bachelor of Science in Computing Science with the Bachelor of Arts in International Studies.

All arrangements currently in force for both the Bachelor of Science in Computing Science and the Bachelor of Arts in International Studies apply equally to the combined degree program in Computing Science and International Studies.

To graduate, a student is required to have completed 240 credit points: 144 credit points in Computing Science and 96 credit points in International Studies.

All students enrolled in the Bachelor of Science in Computing Science are required to pass two Industrial Training subjects. There are a substantial number of prerequisites for Industrial Training, which in this combined degree program is normally undertaken in part-time Years 5 and 6. To gain credit for Industrial Training, students are required to obtain an approved, full-time job within the information technology industry.

The Bachelor of Arts in International Studies requires undergraduates to study a major – a region or country of specialisation – over a minimum of three years. Students study language and culture for at least two years in Sydney, and this is followed by a period of study overseas.

Each of the specialisations within the International Studies program is 96 credit

points, and includes 32 credit points (four subjects) of instruction in an appropriate Language and Culture; 16 credit points (two subjects) of the study of Contemporary Society and its context; and 48 credit points (two semesters) of study at a university or institution of higher education in the country or region of specialisation.

The International Studies subjects listed in the course structure are subjects of enrolment referring to common units of instruction across the University.

### Language and Culture

Study of Language and Culture at UTS depends on the individual student's level of language proficiency before entry to the UTS program. There is a range of entry levels to the various Language and Culture programs available. Most are available at beginner's and post-HSC levels, and some at more advanced levels.

The following Language and Culture programs will be available at UTS as part of the International Studies program: Cantonese, Chinese, Indonesian, Japanese, Malay and Spanish. In addition, arrangements have been made for the delivery of Croatian, French, German, Greek, Italian, Polish, Russian, Slovenian, Ukrainian and Thai.

### Contemporary Society

For each specialisation of the International Studies program, students have a prescribed pair of units of instruction in Contemporary Society, taught by the Institute for International Studies in cooperation with the Faculty of Humanities and Social Sciences.

The first is a subject on Modernisation and Social Change that provides a general introduction to comparative social and political change. It is designed to locate further study of the major in its intellectual and physical contexts.

The second is a subject that provides a more detailed introduction to the student area of specialisation and students do the subject as appropriate to their major. The subjects are:

- Contemporary Latin America
- Contemporary China
- Contemporary Europe
- Contemporary South-East Asia
- Contemporary Japan
- Chinese East Asia

## In-country Study

Students with a basic level of language competence will usually follow a program of study which will continue to develop their knowledge and understanding of the host country's language and culture. Those whose level of language competence is adequate will study subjects related to the development of the contemporary society – history, economics, politics, society and culture – of the host country alongside students from that country. Those whose level of language competence and understanding of local culture is close to that of a native speaker may choose freely from a wide range of subjects with the approval of the host university and the Institute for International Studies. Where students have reached an appropriate level of language competence, arrangements may be made to substitute one or two semesters of industrial experience for periods of In-country Study. In-country industrial experience undertaken in this way will be assessed by UTS in a manner similar to subjects of In-country Study, though through cooperation between the Institute for International Studies and the School of Computing Sciences.

## Course program

For details of International Studies subjects, students should refer to the School of Mathematical Sciences' 'Subject descriptions' section in this handbook.

### Year 1

#### Autumn semester

31414	Information Systems	6cp
31415	Principles of Software Development A	6cp
31416	Computing Systems Architecture	6cp
31417	Computing Practice	6cp

#### Spring semester

31424	Systems Modelling	6cp
31425	Principles of Software Development B	6cp
31428	Quantitative Modelling	6cp
31429	Procedural Programming	6cp

### Year 2

#### Autumn semester

31434	Database Design	6cp
50140	Modernisation and Social Change	8cp
971xxx	Language and Culture 1	8cp
	Computing Science elective	6cp

#### Spring semester

31436	Systems Software and Networks	8cp
972xxx	Language and Culture 2	8cp
	Computing Science elective	6cp

### Year 3

#### Autumn semester

31444	Systems Design and Development	10cp
973xxx	Language and Culture 3	8cp
	Computing Science elective	6cp

#### Spring semester

22615	Accounting Information Systems	6cp
974xxx	Language and Culture 4	8cp
976xxx	Contemporary Society	8cp

### Year 4

#### Autumn semester

977xxx	In-country Study 1	24cp
--------	--------------------	------

#### Spring semester

978xxx	In-country Study 2	24cp
--------	--------------------	------

### Year 5

#### Autumn semester

31455	Software Development Case Study	5cp
31698	Industrial Training	0cp
	Computing Science elective	6cp

#### Spring semester

31455	Software Development Case Study (cont.)	5cp
31698	Industrial Training	0cp
	Computing Science elective	6cp

### Year 6

#### Autumn semester

31454	Project Management and the Professional	8cp
31699	Industrial Training	0cp
	Computing Science elective	6cp

#### Spring semester

31464	Information Technology Planning and Design	6cp
31699	Industrial Training	0cp
	Computing Science elective	6cp



## Bachelor of Science in Computing Science/ Bachelor of Laws

### Course code: LL06

The BSc LLB is offered jointly with the Faculty of Law. The course is of five years' duration and is offered only on a full-time basis (although students will be expected to attend some evening lectures). The program will allow students the option of undertaking a legal practice major as part of their undergraduate studies.

The course will be submitted to the Australian Computer Society as satisfying the requirements of the Society for admission as an associate member.

Students enrol with the Faculty of Law, and are required to complete a total of 240 credit points, 94 in Computing Science and 146 in Law. In addition, students must complete a period of industrial training before graduation, ideally in a legal environment.

Students will be awarded **two** degrees and therefore will receive **two** testamurs on graduation. Students who elect not to complete the joint degree may be permitted to complete a Bachelor of Science in Computing Science or a Bachelor of Laws as a stand-alone degree.

The Faculty of Law administers the course. The current program is shown below. For full details of Law subjects, students should consult the *Faculty of Law Handbook*. Inquiries should be directed to the Faculty of Law on 9281 2699.

### Course program

#### Year 1

##### Stage 1

31415	Principles of Software Development A	6cp
31417	Computing Practice	6cp
70105	Legal Research	4cp
70113	Legal Process and History	10cp

##### Stage 2

31425	Principles of Software Development B	6cp
31429	Procedural Programming	6cp
70211	Law of Contract	8cp
70217	Criminal Law	6cp

#### Year 2

##### Stage 3

31414	Information Systems	6cp
31416	Computer Systems Architecture	6cp
70311	Law of Tort	8cp
70616	Federal Constitutional Law	8cp

##### Stage 4

31424	Systems Modelling	6cp
31428	Quantitative Modelling	6cp
70317	Real Property	8cp
70318	Personal Property	4cp

#### Year 3

##### Stage 5

31434	Database Design	6cp
31436	Systems Software and Networks	8cp
70617	Administrative Law	8cp
70417	Corporate Law	8cp

##### Stage 6

31444	Systems Design and Development	10cp
70516	Equity and Trusts	8cp
76xxx	Elective subject 1	6cp

#### Year 4

##### Stage 7

31455	Software Development Case Study <sup>1</sup>	5cp
71005	Practice and Procedure	4cp
71216	Law of Evidence	6cp
76xxx	Elective subject 2	6cp
76xxx	Elective subject 3	6cp

##### Stage 8

31464	Information Technology Planning and Design <sup>1</sup>	6cp
31455	Software Development Case Study (cont.) <sup>1</sup>	5cp
71116	Remedies	6cp
76xxx	Elective subject 4	6cp

#### Year 5

##### Stage 9

31454	Project Management and the Professional Industrial experience	8cp
-------	---------------------------------------------------------------	-----

##### Stage 10

Legal practice major (PLT) or four law electives	24cp
--------------------------------------------------	------

<sup>1</sup> These subjects may be replaced by Computing Science electives with the approval of the Head of School of Computing Sciences.

## Double degree in Business and Computing Science

Students initially enrol in the Bachelor of Business degree and take the 'Programming and Design' sub-major offered by the School of Computing Sciences. On satisfactory completion of the Business degree and the 'Programming and Design' sub-major, students may then apply for admission to the Bachelor of Science in Computing Science degree. If admitted, students will receive exemptions for the computing core subjects they completed in the Programming and Design sub-major. They will also receive 24cp of exemptions for electives, the equivalent of a Business sub-major in the Computing Science degree.

Students considering this double degree should talk to an academic advisor in the School of Computing Sciences before beginning the sub-major.

Full details of the Bachelor of Business degree are contained in the *Faculty of Business Handbook*.

## Bachelor of Science (Honours) in Computing Science

**Course code: MC08**

This program will be offered in two forms. The first is an extension to the BSc (Computing Science). The degree will have a total of 168 credit points. Students will initially enrol in the standard BSc (Computing Science), and be invited to join the Honours program at the end of the second year. They will then complete a total of 120 credit points of Pass degree subjects, and 48 credit points of Honours subjects as outlined below. Full-time students will be able to complete the Honours program in four years, part-time students in seven years. These students will receive one testamur on completion of the program.

The second form of offering will be as a 48 credit points program for students with pass degrees in computing from other universities or other appropriate programs within UTS. These students will be able to take the degree as one year full-time or two years part-time, and will receive this degree as a separate testamur.

The aim of the Honours program is to provide students with a sound research methodology and the experience of undertaking a major research oriented project; to provide for the study in depth of particular topics in information technology; and to provide students with a basis for postgraduate research or a career in industrial research and development.

### Program – version integrated with existing BSc

#### Recommended full-time program

##### First and second years

As for existing BSc (Computing Science)

##### Year 3

#### Autumn semester

31696	Industrial Training	
31945	Introduction to Computing Research	6cp
31948	Honours Seminar 1	6cp

#### Spring semester

31697	Industrial Training	
31946	The Computing Literature	6cp
31949	Honours Seminar 2	6cp

**Year 4****Autumn semester**

31454	Project Management and the Professional	8cp
31455	Software Development Case Study	5cp
31947	Honours Research Project	12cp

**Spring semester**

31455	Software Development Case Study	5cp
31464	Information Technology Planning and Design	6cp
31947	Honours Research Project (subject continues)	12cp

**Recommended part-time program****First to fourth years**

As for existing BSc (Computing Sciences)

**Year 5****Autumn semester**

31455	Software Development Case Study	5cp
31945	Introduction to Computing Research	6cp
31698	Industrial Training	

**Spring semester**

31455	Software Development Case Study	5cp
31948	Honours Seminar 1	6cp
31698	Industrial Training	

**Year 6****Autumn semester**

31454	Project Management and the Professional	8cp
31949	Honours Seminar 2	6cp
31699	Industrial Training	

**Spring semester**

31464	Information Technology Planning and Design	6cp
31946	The Computing Literature	6cp
31699	Industrial Training	

**Year 7****Autumn semester**

31947	Honours Research Project	12cp
-------	--------------------------	------

**Spring semester**

31947	Honours Research Project (subject continues)	12cp
-------	----------------------------------------------	------

**Program – Stand-alone****Full-time version****Autumn semester**

31945	Introduction to Computing Research	6cp
31946	The Computing Literature	6cp
31947	Honours Research Project	12cp

**Spring semester**

31948	Honours Seminar 1	6cp
31949	Honours Seminar 2	6cp
31947	Honours Research Project (subject continues)	12cp

**Program – Stand-alone****Part-time version****Year 1****Autumn semester**

31945	Introduction to Computing Research	6cp
31948	Honours Seminar 1	6cp

**Spring semester**

31946	The Computing Literature	6cp
31949	Honours Seminar 2	6cp

**Year 2****Autumn semester**

31947	Honours Research Project	12cp
-------	--------------------------	------

**Spring semester**

31947	Honours Research Project (subject continues)	12cp
-------	----------------------------------------------	------

Similar arrangements will exist for the two combined degrees BSc (Computing Science)/LLB and BSc(Computing Science)/BA (International Studies) and the double degree with Business.

**Honours electives**

The Honours electives may be offered specifically to Honours students in the School, may be drawn from subjects in the Master of Science in Computing (by coursework) or other postgraduate level programs, or may be drawn from the Honours program at, say, the University of Sydney. Student will tailor the elective program to their needs, and may not be restricted to the above sources. A list of available Honours electives will be issued each year to eligible students.

## Progression rules

Any student who fails any Honours subject will not be allowed to receive an Honours award. Students combining Honours with the BSc (Computing Science) will be considered for the Pass degree; students doing a stand-alone Honours program will have to show cause as to why they should not be excluded.

## Industrial experience and Honours

To meet the objectives of the proposed Honours program within four full-time academic years, it will be necessary for Honours students to undertake the 24 credit points of Honours methodology and elective subjects while they are doing their industrial training, normally as two 6 credit point subjects per semester. However, students who are anticipating enrolling in Honours will be encouraged to choose research-oriented industrial training where possible. Part-time students will have to complete the Honours project during a seventh year to complete the Honours program. All specific Honours subjects will be run at night, or possibly in intensive mode, perhaps during break periods to cater for both full- and part-time students.

It is expected that most full-time students will have finished the non-project requirements of the Honours program by the end of the industrial training year. The project will be spread over two semesters for all students.

## Grading of Honours

Grading of Honours will be based on the Honours program alone. It is anticipated that there will be an external assessor.

## Bachelor of Computing

### Course code: MC06

The Bachelor of Computing is open only to students who do not have Australian resident status. It is full fee paying. It provides a three year full-time course of academic study. Students may commence either semester. Its aims are to provide international students with a sound appropriate education in computing and information systems and to foster international links for the School of Computing Sciences.

### Selection of students

Students will apply through International Programs, but will be assessed by the School. Students will be required to have at least the equivalent of a NSW HSC matriculation, and to meet or better the University's IELTS criteria.

### Exemptions

Exemptions may be granted on the basis of recent academic study (within the last three years) at post-secondary level. Students must be able to demonstrate that the knowledge is current. Exemptions from core subjects may be granted where subjects successfully completed previously coincide with BComp subjects. Students are expected to apply for exemptions for which they believe they are eligible, at the commencement of their first year of study. Exemptions are usually processed by the School immediately following enrolment.

### Course program

#### Year 1

##### Semester 1

xxxxx	Australian Studies 1	6cp
31507	Australian Studies 2	6cp
31417	Computing Practice	6cp
31414	Information Systems	6cp

##### Semester 2

31424	Systems Modelling	6cp
31508	Programming Fundamentals	6cp
31509	Computer Fundamentals	6cp
31425	Principles of Software Development B	6cp

## Year 2

**Semester 3**

31434	Database Design	6cp
31429	Procedural Programming	6cp
31510	Operating Systems	6cp
	Elective 1	6cp

**Semester 4**

31511	Systems Design	6cp
31512	Networking 1	6cp
31428	Quantitative Modelling	6cp
	Elective 2	6cp

## Year 3

**Semester 5**

31454	Project Management and the Professional	6cp
22615	Accounting Information Systems Special IS/CS elective	6cp
	<i>or</i>	
31514	Computing Theory	6cp
	Elective 3	6cp

**Semester 6**

31464	Information Technology Planning and Design Special IS/CS elective	6cp
	<i>or</i>	
31514	Computing Theory	6cp
31931	Software Quality Assurance	6cp
	Elective 4	6cp

**Notes:** The subject Computing Theory will only be offered in one semester each year. If, for example, it is offered in Autumn, students in an Autumn intake will take it in their fifth semester, and students who start in Spring will take it in their sixth semester.

The 'Special IS/CS (Information Systems/Computing Science) elective' will be one of the following 6 cp subjects:

- Distributed Databases
- Networking 2
- Human-Computer Interaction
- Object-oriented Methodologies

The four elective subjects (a total of 24 credit points) may be taken from any of the School of Computing Sciences electives (and may include any of the subjects listed in Note 1 not taken as the Special IS/CS elective), or the students may take one of a small set of approved sub-majors from other schools and faculties. These have not been fully identified, but sub-majors such as International Finance, or International Management are envisaged.

## Bachelor of Computing/ Bachelor of Arts in International Studies

**Course code: MC07**

This course is available only to international students. It combines the Bachelor of Computing with the University's Bachelor of Arts in International Studies. For the details of the latter course, please see the section in this handbook on the Bachelor of Science in Computing Science/Bachelor of Arts in International Studies within this section.

# Postgraduate courses

General inquiries should be directed to either the University Graduate School, telephone 9514 1523, or the Faculty's Graduate Administration Officer, telephone 9514 1806. Applicants for research degrees should discuss their proposed research with either the Director, Postgraduate Studies, or their chosen supervisor before submitting applications. The Faculty's Graduate Administration Officer can assist applicants in contacting members of staff, and in completing the application form.

## POSTGRADUATE RESEARCH DEGREES

### Research areas

Areas of particular interest for work towards research degrees in the School of Computing Sciences include:

- computer graphics, image processing
- computer performance evaluation
- computer-supported cooperative work
- distributed and object databases
- distributed multimedia
- distributed systems
- information processing strategy, systems management
- local networks and network interface technology
- logic in computer science
- machine intelligence, knowledge-based systems
- neural networks
- parallel processing and transputers
- quality of systems and software
- semantics and design of programming languages
- usability of systems and software

### Computing Sciences research laboratories

Within the School, a wide range of information technology research is supported by a variety of research laboratories. Graduate research students, academics, visiting researchers and research assistants undertake collaborative research within these laboratories. The quality and relevance of research in the laboratories is enhanced by well-established links, both with industry and with overseas research institutions.

The major laboratories are:

**Parallel Processing Laboratory** – examines and applies transputer technology to real-world tasks, distributed operating systems and compilation. The laboratory has a configuration of over 40 transputer systems (contact: Ury Szewcow).

**Computer Graphics Laboratory** – using seven Silicon Graphics workstations, this laboratory is concerned with the development of realistic images and computer animation. Other areas include efficient contour algorithms, human movement, image animation and textual modelling (contact: Dr Kevin Suffern).

**Cooperative Systems Laboratory** – focuses on the implementation and data modelling of distributed databases, client-server computing and cooperative workgroup systems. Development of methods for integrating databases with expert systems, modelling of constraints and development of design tools. Integration of groupware with databases (contact: Dr George Feuerlicht or Professor Igor Hawryszkiewicz).

**Software Research Laboratory** – includes three groups:

*Algorithms and Languages Group* – investigates programming languages and paradigms, logic in computer science, database theory, concurrency, software engineering and formal methods, and category theory (contact: Dr Barry Jay or Dr Ron van der Meyden).

*Artificial Intelligence Group* – interests include AI in design, case-based reasoning, cognitive modelling, knowledge engineering, PROLOG and LISP (contact: Professor John Debenham).

*Adaptive Methods Group* – applies neural networks, genetic programming and other machine learning methods to problems of varying complexity, including image analysis,

forecasting and natural language (contact: Dr Tom Osborn).

**CRC Distributed Systems Technology Laboratory** – the primary focus is management security and performance for controlled and efficient access to the resources of distributed systems such as database, collaboration software and distributed software tools (contact: Associate Professor Mike Fry).

**Distributed Multimedia Laboratory** – examines technology, protocols and implementation issues for very high-bandwidth multimedia technology over computer networks. Work includes distance interaction of design editing and performance groups and network traffic performance, supporting diverse components (contact: Associate Professor Mike Fry).

**Usability Laboratory** – investigates the methods and measurement techniques for developing effective and usable human-computer interaction methods, for different kinds of operating environments including design and system development (contact: David Wilson or Judy Hammond).

## Doctor of Philosophy

### Course code: MC54

The Doctor of Philosophy (PhD) is intended for students who wish to pursue research at the highest level; such research is expected to demonstrate significant originality and make a substantial contribution to computing knowledge. For specific areas of interest of research in the School of Computing Sciences, refer to the 'Research areas' section above.

### Attendance pattern

The Doctor of Philosophy degree is available on both a full-time and a part-time basis. The normal duration of enrolment is three years for full-time attendance and six years for part-time attendance. Candidates who already possess a degree at the Master's level may be permitted to complete their PhD in two years of full-time research, or three years of part-time research. The maximum duration of enrolment is five years for full-time students and seven-and-a-half years for part-time students.

The School of Computing Sciences has a strong preference for research work that proceeds at a full-time pace. This preference should not be seen as a deterrent to those students who wish to remain in employment. Students who are

working in a full-time job are encouraged to select a topic for their research which is closely aligned with their professional work. Once such a topic has been selected, the School usually requires that the student's employer provide a statement to the effect that at least half of the student's working week will be devoted to work which is directly relevant to the research. The student is then expected to contribute some of his or her own time to the project so that the total number of hours devoted to research is that expected of full-time attendance.

### How to apply

Application forms for all postgraduate courses may be obtained from the UTS Information Service. Applicants should hold a First Class or Second Class (Division 1) Honours degree with a major computing component, or a Master's degree in an appropriate area, or have previously undertaken other postgraduate studies in computing. Prospective applicants are expected to have developed interests in a specific area of research, and should have one or more outline proposals for research work in that area. Before submitting a formal application for admission to this degree course, applicants should first seek the approval of the School for their proposed research work. To gain this approval, applicants should initially:

*Either* send a summary proposal of approximately 1,000 words to the Director, Postgraduate Studies, School of Computing Sciences, containing references to seminal works in the area of proposed research. If the proposal is appropriate for the School, the Director will then refer the applicant to a suitable member of staff for further detailed discussion;

*or* approach a suitable member of the School's academic staff directly and discuss the proposed research area.

All Doctor of Philosophy students at UTS are required to have at least two supervisors for their research work, one of whom should be an academic staff member of the University and, normally, one of whom should hold a Doctoral degree. Of the two supervisors, one will be the principal supervisor, and the other the co-supervisor.

Prospective applicants should seek agreement from a member of the School's academic staff to act as a (principal) supervisor for the proposed research if the application is successful. Once this agreement has been

obtained, applicants may then apply formally for admission by completing an Application for Candidature – Doctoral Degrees form and the Faculty's Supplementary Doctoral Application form. These forms must be signed by the applicant, the proposed supervisor and the Head of School.

### Course fees

Fees will be levied in accordance with University policies and DEETYA guidelines. Details will be available in early 1998.

### Progress reports

All Doctor of Philosophy students are required to submit, in consultation with their supervisors, a progress report at the end of each semester. The University Graduate School contacts each student and their supervisor/s to initiate this process. Students are also required to complete a Doctoral Assessment and seminar.

### Submission of thesis

All candidates for the degree of Doctor of Philosophy should give the Registrar two months' written notice of intention to submit their written thesis. Appropriate forms and the information brochure *Presentation and Submission of Theses for Higher Degrees* are available from the University Graduate School.

### Recent theses

Stewart, B 1996, Learning of probabilistic models from data.

Blair, A 1997, MEDIDSS: A methodology for the design of the intelligent decision support systems.

Ray, P K 1997, Cooperative management of enterprise networks.

Robinson, T A 1997, Designing over distance, a study of cooperative work, embodied cognition and technology to enable remote collaboration.

Sifer, M 1997, Structured Graphics: Visual formalism for SCALABLE graph based tools and its application to software structured analysis.

Sheridan, P 1997, Spiral architecture for machine vision.

Unhelkar, B 1997, Effect of granularity of object-oriented design on modelling an enterprise, and its application to financial risk management.

## Master of Science

### Course code: MC51

The Master of Science degree enables graduates to extend and deepen their knowledge of a specialised area in computing by undertaking research under the supervision of a member of the academic staff. For specific areas of interest in research work in the School of Computing Sciences, refer to the 'Research areas' section above.

### Attendance pattern

This degree is available on both a full-time and a part-time basis. The normal duration of enrolment for this degree is two years for full-time attendance or three years for part-time attendance. The maximum time to complete the course is three years for full-time students and four-and-a-half years for part-time students.

The School of Computing Sciences has a strong preference for research work that proceeds at a full-time pace. This preference should not be seen as a deterrent to those students who wish to remain in employment. Students who are working in a full-time job are encouraged to select a topic for their research which is closely aligned with their professional work. Once such a topic has been selected, the School usually requires that the student's employer provide a statement to the effect that at least half of the student's working week will be devoted to work which is directly relevant to the research. The student is then expected to contribute some of his or her own time to the project which brings the total number of hours devoted to research within that expected of full-time attendance.

### How to apply

Application forms for all postgraduate courses may be obtained from the UTS Information Service. Applicants should hold a First Class or Second Class (Division 1) Honours degree with a major computing component, or have previously undertaken other postgraduate studies in computing. Prospective applicants are expected to have developed interests in a specific area of research, and should have one or more outline proposals for research work in that area. Before submitting a formal application for admission to this degree course, applicants should first seek the approval of the



School for their proposed research work. To gain this approval, applicants should initially: *Either* send a summary proposal of approximately 1,000 words to the Director, Postgraduate Studies, School of Computing Sciences, containing references to seminal works in the area of proposed research. If the proposal is appropriate for the School, the Director will then direct the applicant to a suitable member of staff for further detailed discussion;

*or* approach a suitable member of the School's academic staff directly and discuss the proposed research area.

Every Master of Science student at UTS is required to have at least two supervisors for their research work, one of whom should be an academic staff member of the University. Of the two supervisors, one will be the principal supervisor, and the other the co-supervisor.

Prospective applicants should seek agreement from a member of the School's academic staff to act as a supervisor for the proposed research if the application is successful. Once this agreement has been obtained, applicants may then apply formally for admission by completing an Application for Admission – Graduate Courses form and the Faculty's Details of Proposed Study form. These forms must be signed by the applicant, the proposed supervisor and Head of School.

## Course fees

Fees will be levied in accordance with University policies and DEETYA guidelines. Details will be available in early 1998.

## Progress reports

All thesis students are required to submit, in consultation with their supervisors, a progress report at the end of each semester. The University Graduate School contacts each student and their supervisor/s to initiate this process.

## Submission of thesis

Each candidate for the degree of Master of Science should give the Registrar two months' written notice of their intention to submit their written thesis. Appropriate forms and the information brochure *Presentation and Submission of Theses for Higher Degrees* are available from the University Graduate School.

## Recent theses

Charif, A 1996, Genetic logic programming for natural language understanding.

Fuller, A L 1996, Class based domain modelling.

Hallewell Haslwanter, J D 1996, Systems development methodologies in the context of HCI.

Parsons, A 1997, Network management in a DEC environment.

Thorne, F 1997, A software classification scheme for re-use.

## POSTGRADUATE COURSEWORK PROGRAMS

### Master of Science in Computing

**Course code:** MC53

The Master of Science in Computing is a professional course. Graduates select a program of study that suits their individual career goals. For example, a program may be chosen which develops specialised expertise in computer systems, which provides a general update of information systems, or which equips the student for a position in management.

#### Attendance pattern

The course is offered on a part-time basis only, over six semesters (three years), because it is considered important that students remain in professional employment while undertaking this course. Attendance is normally required at lectures for at least two evenings per week. As the course is only available part time, all timetabled sessions are held in the evenings. These are usually held between 6.00 p.m. and 9.00 p.m.

#### How to apply

The course is intended for computing professionals. Applicants should have **both**:

- a Bachelor's degree from the University of Technology, Sydney, or equivalent, preferably with a major computing component. Applicants are required to submit evidence to the effect that the extent of their formal knowledge of computing is equivalent to that of a graduate from the UTS Bachelor of Science in Computing Science;
- and*
- an established professional career within the information industry. As a guide, the extent of the applicant's professional experience should be equivalent to that of an Associate Member of the Australian Computer Society of at least two years' standing.

Each semester the School publishes the *MSc in Computing (by coursework)* Course Guide. This Course Guide contains much administrative information as well as a detailed statement of the course regulations. Students and prospective applicants are advised to obtain a

copy of the Course Guide and to study it carefully. From August each year an 'Admission package' containing a copy of the Course Guide, the application forms and other relevant information is available from the UTS Information Service. Please note that completed application forms must be submitted to the University by the published deadline, which is usually the last week of October in the year prior to that in which admission is sought. Applicants may be required to attend an interview.

#### Course fees

The Master of Science in Computing is offered with a fixed quota of student places and the course fees have been set in accordance with University policy. For students commencing in 1998, tuition fees will be set at \$2,040 per semester for a normal attendance pattern. Course fees are revised from year to year in accordance with University and government policy. Details of the current fee structure may be obtained from the University Graduate School.

#### Prerequisite knowledge

All subjects in the Master of Science in Computing course are presented at the postgraduate level. Students are expected to be familiar with the undergraduate material that lies behind the postgraduate work.

For the subjects offered by the School of Computing Sciences, before the start of each semester a set of references to the presumed undergraduate material is given by each lecturer. It is important to note that these references are not 'pre-reading', but are a summary of the undergraduate knowledge required for each subject. Students are responsible for ensuring that they are completely familiar with the undergraduate knowledge implied by those references. If they are not, then they should defer their enrolment in that subject and should attend suitable remedial undergraduate lectures as advised by the Director, Postgraduate Studies.

For a subject offered by faculties or schools other than the School of Computing Sciences, students are advised to contact that subject's Coordinator before the start of semester, to determine whether they possess the prerequisite knowledge for that subject. If students do not possess the prerequisite knowledge, they should seek advice from those schools or faculties on the feasibility of a remedial program. The Director, Postgraduate Studies, will assist in obtaining this advice.

### Course structure

Students are required to complete a total of 72 credit points, consisting of 60 credit points from coursework and 12 credit points from the Project subject. The Project subject is normally taken in the sixth semester and must be completed by all students. In special circumstances, the Director, Postgraduate Studies, may approve a program of 72 credit points, consisting of 48 credit points from coursework and 24 credit points from the Project subject. Students who are allowed to undertake a 24-credit-point project must have the strong support of their Project Supervisor as a part of these 'special circumstances'.

Each student's program of study will be subject to approval by the Director, Postgraduate Studies. The subjects chosen by a student must form a coherent plan of study and must be consistent with the student's professional career goals. When approving a student's program of study, the Director, Postgraduate Studies, will not permit a student to enrol in a subject in the Master of Science in Computing if that student has already completed a similar subject in another course.

Principal subjects in the Master's course are subjects offered by the School of Computing Sciences on a regular basis. Elective subjects in the Master's course are subjects offered by the School of Computing Sciences on a periodic basis; the elective subjects may vary from year to year depending on the availability of specialist staff.

To gain their credit points from coursework (normally amounting to 60 credit points), students are required to gain at least 36 credit points by passing a selection of principal subjects; with the balance, which will thus be at most 24 credit points, to be made up as follows:

- by passing postgraduate subjects which are made available to students in the Master of Science in Computing course by the School of Mathematical Sciences or by other faculties;
- or*
- by passing elective subjects up to a total of 12 credit points only. (In special cases, when the student has specific requirements, the Director, Postgraduate Studies, may extend this to a total of 18 credit points of elective subjects but no further.)

**Subject outline timetable**

The principal subjects are as follows:

Subject number	Subject name	CP	Semester offered
<i>Computer Science</i>			
32901	Recent Advances in Computer Science	6	A98, A99
<i>Computing Methods</i>			
32106	Object-oriented Software Development	6	A99
32107	Formal Reasoning for Software Development	6	S99
32108	Specialist Topics in Artificial Intelligence	6	S98
<i>Computer Systems</i>			
32306	Capacity Management	6	A98
32307	Operating Systems	6	S98
32308	Computer Architecture	6	S99
<i>Information Systems</i>			
32902	Recent Advances in Information Systems	6	A98, A99
<i>Information Systems Technology</i>			
32204	Advanced Data Management	6	A98
32205	Computer Communication Systems	6	S98
32206	Advanced Information Systems Modelling	6	S99
<i>Information Systems Management</i>			
32207	Information Management	6	A99
32208	Information Processing Strategy	6	S99
32402	Information Technology Environment	6	S98
32912	Project	12	All
32924	Project	24	All

A major review of the course will take place in 1998 and there will be some new subjects in 1999.

Each principal subject is of one semester's duration. Principal subjects are offered once every two years, with the exception of 32901 Recent Advances in Computer Science and 32902 Recent Advances in Information Systems which are offered each year. At present the intention is to offer the above principal subjects on a two-year cycle; however, the Master's program is constantly under review, and it is expected that the list of principal subjects offered will be expanded, and that the contents and sequence of existing principal subjects may be modified.

The elective subjects present specialised material and so will depend on the availability of specialist staff. At present, the full range of elective subjects is listed below.

**Elective subjects**

32501	Computer Graphics	6cp
32502	Advanced Computer Graphics Techniques	6cp
32503	Distributed Databases and Client/Server Computing	6cp
32506	Knowledge Systems	6cp

32508	Software Quality Management Systems	6cp
32509	Human-Computer Interaction in Information Systems	6cp
32510	Principles of Object-oriented Programming in C++	6cp
32511	Principles of Object-oriented Programming in Smalltalk	6cp
32512	Advanced Knowledge Technology	6cp
32513	Advanced Machine Learning	6cp
32514	Advanced Case-based Reasoning	6cp
32516	Internet Programming	6cp
32517	Commerce on the Internet	6cp
32520	UNIX Systems Administration	6cp
32521	Internetworking	6cp
32522	C for System Programmers	6cp
32523	Operating Systems for Internetworking	6cp
32524	LANs and Routing	6cp
32525	Distributed Software Programming	6cp
32526	Designing the Networked Enterprise	6cp

### Subjects from other schools or faculties

The following subjects from other schools or faculties are available to students in the MSc in Computing as electives. Students should contact the relevant school or faculty for prerequisites.

#### School of Mathematical Sciences

35443	Advanced Mathematical Programming	4cp
35448	Dynamic Optimisation	4cp
35457	Multivariate Statistics	4cp
35459	Linear Models and Experimental Design	4cp
35466	Advanced Stochastic Processes	4cp
35467	Time Series Analysis	4cp
35485	Advanced Financial Modelling	4cp

#### Faculty of Business

21702	Industrial Relations	6cp
21718	Organisation Analysis and Design	6cp
21719	Organisational Behaviour	6cp
21720	Employment Relations	6cp
21722	Leadership and Management Action	6cp
21724	Human Resource Management	6cp

21741	Operations Management	6cp
22747	Accounting for Managerial Decisions	6cp
22751	Corporate Accounting Issues	6cp
24734	Managerial Marketing	6cp
24737	Marketing Information Management	6cp
25706	Economics for Management	6cp
25707	Government Business Relations	6cp
25741	Capital Markets	6cp
25742	Financial Management	6cp

#### Faculty of Law

72100	Legal Process	12cp
77793	Computer Law	6cp
77815	Patent Law	12cp
77816	Design Law	12cp
77819	Copyright Law	12cp
79703	Legal Aspects of Contracts Administration	6cp
79708	Contemporary Business Law	6cp
79741	Marketing Legislation in Australia	6cp
79749	Law for Managers – Administration	6cp
79771	Dispute Resolution	6cp

## Choosing a program in 1998

Students may find this presentation of principal subject offerings useful when choosing their program. It is usually easiest to choose the principal subjects first because most of these are only available every two years, and then to select the remaining subjects. Students should be sure to take the prerequisites into account (see 'Subject descriptions' section for the School of Computing Sciences). Ideally, there should be two subjects chosen per semester for the first two years. During the final year, students normally take the Project subject and two coursework subjects.

Semester	Computer Methods	Computing Systems	Information Systems Technology	Information Systems Management
A 98	Recent Advances in Computer Science	Capacity Management	Advanced Data Management	Recent Advances in Information Systems
S 98	Specialist Topics in Artificial Intelligence	Operating Systems	Computer Communication Systems	Information Technology Environment
A 99	Object-oriented Software Development	Recent Advances in Computer Science	Recent Advances in Information Systems	Information Management
S 99	Formal Reasoning for Software Development	Computer Architecture	Advanced Information Systems Modelling	Information Processing Strategy
A 00	Recent Advances in Computer Science	Capacity Management	Advanced Data Management	Recent Advances in Information Systems
S 00	Specialist Topics in Artificial Intelligence	Operating Systems	Computer Communication Systems	Information Technology Environment

Note: The program shown for 1999 and 2000 is provisional.

## Project

The project entails a substantial investigation of a topic in an area of current research interest in Information Technology that is related to the student's professional career goals. All students are required to enrol in and pass the Project subject. The project is normally undertaken in the final year of study after the completion of at least two years of coursework.

The topic for the project should be:

- of direct interest to the student,
- and*
- of value to the student's professional development.

Students may wish to select a topic that is closely related to their current employment. Alternatively, students may wish to choose a topic that would be of value to their future career. The project should be a vehicle for importing the knowledge learnt from the coursework into the student's professional life. The topic should be chosen with this professional goal in mind. Students are advised to seek the assistance of the lecturing staff in finalising the topic for their project.

Before beginning the project work a student must:

- obtain the agreement of a member of the lecturing staff to act as project supervisor,
- and*
- deliver a 500-word description of the project to the Director, Postgraduate Studies, for approval.

Once approved, the project will proceed 'in the manner of a Master's thesis', and students are advised to discuss their work with their project supervisor regularly. The role of the project supervisor is to:

- advise on the general direction of the investigation;
- advise on a work schedule;
- advise on a framework for writing up the work;
- and*
- criticise draft sections of work.

It is usual for the project work to extend over more than one semester. Students should enrol in the project for the semester in which they hope to submit their completed project. Students should note the requirement, stated below, for the project to be submitted before the end of the tenth week of the semester in

which they wish to have their project examined. The examination of the project must be completed before the School's Examination Review Committee meeting for that semester. This meeting takes place towards the end of each semester. If a student is enrolled in the Project subject at the time of the School's Examination Review Committee meeting, and if the examination of their project has not been completed in time for that meeting, then the enrolment in the Project subject for that semester will be cancelled.

Students usually enrol in a 12-credit-point project. If, in the opinion of the project supervisor, the topic chosen merits a more substantial investigation then the supervisor should make a case to the Director, Postgraduate Studies, for the credit points of the project to be extended to 24. Students should not enrol in the 24-credit-point project unless they have written permission to do so from the Director, Postgraduate Studies.

The project will result in:

- the preparation of an extensive written report, three copies of which should be lodged with the Director, Postgraduate Studies, before the end of the tenth week of the semester in which the student wishes to be examined. All three copies will be retained by the School; one of these will be placed in the University Library. The final version of the report should be typed and bound in accordance with the University's specification for theses (available from the University Graduate School). Students may have their written report bound before submitting it for examination although, to avoid the possible expense of rebinding, three copies of a typed but unbound report may be submitted for examination. When submitted, the written report should be accompanied by a Certificate of Originality and a Retention of Report form. These forms are available from the Director, Postgraduate Studies;
- the presentation of a research seminar of 40 minutes followed by a 20-minute discussion with the examiners. A day will be set for the research seminars each semester. The research seminar day will usually be early in the semester; that is the seminars will be presented by students who submitted their written report in the previous semester. This is to avoid overloading staff and students at the end of semester. Students will be given a mark

for their project when they submit their written report; however all students are required to present their research seminar at a satisfactory standard before they will be permitted to graduate. The research seminar should consist of a discussion of the more highly controversial or technical issues found within the written report. When delivering the research seminar, students should assume that their audience is familiar with the contents of their written report. Note that students do not need to enrol in the Project subject to present their research seminar.

The project will be examined on the content and standard of presentation of the written report and the research presentation. The mark for the Project subject will be determined on the basis of the written report alone.

### Subject failure

Students are permitted, at the most, two failures during the MSc in Computing. Note the resolution of the Faculty Board, FBMC/92/70, that any Master's degree candidate enrolled in the MSc in Computing who records any three failures will have his or her registration from the course discontinued. In addition, students are bound by the Rules of the University, and are advised to refer to them.

### Minimum and maximum time

There are two important University Rules concerning minimum and maximum time of which students should be aware:

- A Master's degree candidate shall not normally be eligible for the award of a Master's degree by coursework until he or she has completed at least six semesters of a part-time course. A student who is specially qualified in a relevant discipline may, with the approval of the Academic Board, be allowed to complete the course in less than the minimum time (Rule 3.3.5.2).
- A student who fails to complete all of the work prescribed for the higher degree within nine semesters from the time of his or her registration as a part-time Master's degree candidate will only be permitted to continue with the approval of the University Graduate School Board (Rule 3.3.7.1).

## Master of Business in Information Technology Management

*Course code: MC85*

## Graduate Diploma in Information Technology Management

*Course code: MC75*

## Graduate Certificate in Information Technology Management

*Course code: MC63*

These courses form a joint program between the School of Computing Sciences and the School of Management in the Faculty of Business. Administration of these courses is the responsibility of the School of Computing Sciences. All inquiries regarding these courses should be directed to Alison Stevens, Professional Programs Manager, on 9514 1925. The courses aim to:

- develop professional skills necessary for successfully undertaking the role of manager in terms of people, resources and processes in a variety of organisational contexts (which may include business, community, public, manufacturing, consultancy or professional contexts);
- enable the acquisition of conceptual and analytical understanding of the corporate/organisational needs from the differing perspectives of individuals and groups within the organisation, necessary for successful management;
- provide a well-balanced selection of subjects from both advanced information technology (IT) and management, in an integrated program which is relevant to the current and future demands of the IT industry;
- develop an understanding of the IT business environment and to extend the knowledge and skills in specialist areas of management related to management of IT in business; and
- enhance and develop a partnership between UTS and the IT industry.

## Admission requirements

### Master's degree

- A recognised Bachelor's degree (or equivalent) in an appropriate discipline such as Business or Computing, plus a minimum of two years' experience in the IT industry;
- or*
- the prior successful completion of the Graduate Diploma in Information Technology Management (such students will therefore be exempt from Semesters 1, 2, 3 and 4);
- or*
- the successful completion of an approved bridging program for non-graduate entry; that is the Graduate Certificate in Information Technology Management with passes in all subjects, and a credit average over the entire course.

### Graduate Diploma

- A recognised Bachelor's degree (or equivalent) in an appropriate discipline such as Business or Computing, plus a minimum of two years' experience in the IT industry;
- or*
- the prior successful completion of the Graduate Certificate in Information Technology Management (such students will therefore be exempt from Semesters 1 and 2), where entry to the Graduate Certificate was based on a recognised Bachelor's degree (or equivalent) in an appropriate discipline such as Business or Computing;
- or*
- the successful completion of an approved bridging program for non-graduate entry; that is the Graduate Certificate in Information Technology Management with passes in all subjects, and a credit average over the entire course.

### Graduate Certificate

- A recognised Bachelor's degree (or equivalent) in an appropriate discipline such as Business or Computing, plus a minimum of two years' experience in the IT industry;
- or*
- evidence of general and professional qualifications, such as other post-secondary school qualifications that can

establish the applicant's aptitude, knowledge and practical experience, which will satisfy the Faculty Board in Mathematical and Computing Sciences that the applicant possesses the educational preparation and capacity to pursue postgraduate studies. (Experience in the IT industry will be especially important in this regard e.g. five years' minimum vocational experience.)

It should be noted that applicants for these courses may be required to attend an interview.

## Presumed knowledge and prerequisites

Subjects in the Graduate Certificate, Graduate Diploma and Master's courses are presented at postgraduate level. Students are expected to be familiar with the undergraduate material on which the postgraduate work is based. For the subjects offered by either the School of Computing Sciences or the School of Management, before the start of each semester a set of references to the presumed undergraduate material is given by each lecturer. It is important to note that these references are not 'pre-reading', but are a summary of the undergraduate knowledge required for each subject. Students are responsible for ensuring that they are completely familiar with the undergraduate knowledge implied by those references. If they are not, then they should seek advice from the Director, Management Development Program (Information Technology), in the first instance and may then be advised to contact the Subject Coordinator before the start of semester, to determine whether they possess the prerequisite knowledge for that subject.

For subjects offered by faculties or schools other than the School of Computing Sciences and the Faculty of Business, students are advised to contact that subject's Coordinator before the start of semester, to determine whether they possess the prerequisite knowledge for that subject. If students do not possess the prerequisite knowledge, then they should seek advice from that school or faculty on the feasibility of a remedial program. The Director, Management Development Program (Information Technology), will assist in obtaining this advice.

In addition, there are prerequisite requirements within the structure of the course itself (see 'Course structure' section).



## Fees

Full tuition fees will be charged for students in the above courses. The fee is \$1,650 per subject (module).

## Course structure

All subjects will be assessed to the Master's standard, regardless of the course in which a student is enrolled. Therefore, a student who takes several individual subjects may later gain credit towards a Graduate Certificate.

The courses have been designed to allow freedom of choice at the individual subject level. The subjects at the Graduate Certificate level aim to teach the student skills and competencies for IT management. At the Graduate Diploma level, the subjects aim to focus on organisational strategies and planning. At the Master's level, the subjects are related to organisational development and research for the IT industry.

The full Master's degree course is normally completed in three years (six semesters) of part-time study. The Project is normally commenced in the fifth semester, together with one subject related to research methodology.

Core subjects are to be offered by the Faculties of Mathematical and Computing Sciences and Business on a regular basis. Additional subjects available on an **elective** basis will be offered depending on demand and the availability of specialist staff (see 'Electives policy', below). The industrially linked Project must build on the core/elective subjects already taken by the student and should ideally be related to his or her place of work.

## Electives policy

Students may take postgraduate level subject(s) from another UTS discipline or another institution, at the discretion of the Director, Management Development Program. Where more than one subject is involved, the subjects would be expected to form a coherent staged group. The student will be expected to provide a written justification as to how the subjects form a coherent staged group. The student will be expected to provide a written justification as to how the subjects form a coherent plan of study that is consistent with their professional career goals.

The student is responsible for ensuring that they have the necessary qualifications and presumed knowledge for any subjects taken from other disciplines or institutions. Students

should also be aware that such subjects may not be presented or documented at the level normally associated with the program.

Exemptions will not normally be granted to students for elective subjects.

### Level 1 – Non-award

A student may take any number of subjects relevant to his or her professional needs. Subject prerequisites, if any, will need to be taken into account.

All subjects will be presented and assessed to the Master's level. Therefore, a student who takes several appropriate subjects may later gain credit towards a Graduate Certificate.

No formal qualification will be awarded by UTS.

### Level 2 – Graduate Certificate in Information Technology Management (24cp)

A student must complete the following **three core** subjects:

21788	Effective People Management	6cp
21789	Contemporary Management Practices	6cp
32601	Advanced Project Management	6cp
	<i>plus one elective subject selected from</i>	
24704	Managing Client Relations	6cp
32602	Impact of Information Technology	6cp
32603	Software Quality Management	6cp
32604	Systems Integration	6cp
32605	Managerial Analysis and Evaluation of Information Systems	6cp
32701	Advances in Information Technology	6cp
32702	Contemporary Telecommunications	6cp
32703	Information Technology Strategy	6cp
32704	Strategic IT Contract Management	6cp

*or*

An elective approved by the Director, Management Development Program (Information Technology)

**Level 3 – Graduate Diploma in Information Technology Management (48cp)**

A student must complete the requirements for the Graduate Certificate in Information Technology Management (24cp);

*plus* complete the following **three core** subjects:

21806	Managing Organisational Change	6cp
21807	Total Quality and Productivity Management	6cp
21808	Strategic Business Management	6cp

*plus* one elective subject selected from the electives listed under Level 2 or an elective approved by the Director, Management Development Program (Information Technology).

**Level 4 – Master of Business in Information Technology Management (66cp)**

A student must complete the requirements for the Graduate Diploma in Information Technology Management (48cp);

*plus* complete the following subjects:

21751	Management Research Methods	6cp
32806	Project A	6cp
32812	Project B	6cp

The major Project must involve applied organisational research and development in the IT industry. It must be industrially linked and conducted in conjunction with the student’s industry sponsor.

A student must make one oral presentation of his or her project work at a satisfactory standard during the final year of enrolment in the Master’s course.

An example of a selected program of study for the Master of Business in Information Technology Management is as follows:

**Year 1**

21788	Effective People Management	6cp
21789	Contemporary Management Practices	6cp
32601	Advanced Project Management	6cp
	Elective	6cp

**Year 2**

21806	Managing Organisational Change	6cp
21807	Total Quality and Productivity Management	6cp
21808	Strategic Business Management	6cp
	Elective	6cp

**Year 3**

21751	Management Research Methods	6cp
32806	Project A	6cp
32812	Project B	6cp

In all cases the subjects chosen must form a coherent plan of study and must be consistent with the student’s professional career goals. Each student’s program of study will be discussed with, and approved by, the Director, Management Development Program (Information Technology), at the time of entry into a course.

**Project**

The project entails a substantial investigation of a topic, in an area of current research interest in information technology and related to the student’s professional career goals. The project is normally taken in the last part of the Master’s course and must be taken and passed by all Master’s students.

A student may wish to select a topic that is closely related to his or her current employment. Alternatively, a student may wish to choose a topic that should be of value to his or her future career. The project should be a vehicle for importing the knowledge learnt from the coursework into the student’s professional life. The topic should be chosen with this professional goal in mind. Students are advised to seek the assistance of the lecturing staff in finalising the topic for their project.

## Master of Interactive Multimedia

**Course code:** MC70

## Graduate Diploma in Interactive Multimedia

**Course code:** MC71

## Graduate Certificate in Interactive Multimedia

**Course code:** MC72

This is a set of articulated offerings:

- Graduate Certificate in Interactive Multimedia 24 cp (core + 8cp)
- Graduate Diploma in Interactive Multimedia 48 cp (core + 32cp)
- Master of Interactive Multimedia 72 cp (core +56cp)

Initially the courses will be offered as part-time study over one, two or three years. Should the demand warrant a full-time course, it may be possible to offer the Graduate Certificate, at least, over one semester full-time. It is a fee paying course. While the program will be managed by the School of Computing Sciences, it is a joint program between the Institute for Interactive Multimedia and a number of teaching faculties.

The program is designed for students from a wide variety of background disciplines who may or may not already be working in areas of multimedia. For this reason, the program contains a considerable number of elective subjects to enable students to gain new areas of knowledge or broaden existing areas. It has also been designed as an articulated program commencing with a Graduate Certificate, then a Graduate Diploma and finally a Master's degree. Some non-graduate entry into the Graduate Certificate only will be possible for applicants with multimedia industry experience. Successful completion of the Graduate Certificate at some appropriately defined level by such students will permit them to articulate into the Graduate Diploma.

All students will undertake a core course of study leading to the award of Graduate Certificate. This will consist of 24 credit points made up of two new eight credit point core subjects at the graduate level and 8 credit points of elective subjects. The two core subjects will be taught by the Institute for

Interactive Multimedia with some guest lectures from other faculties. There will be no exemptions for these subjects.

Students will then be asked to specialise in one of the following areas: Hypermedia from Engineering, various areas in Computing, various areas in Design, Information Studies, Audiovisual Production, Education.

The final component of the Graduate Certificate will be eight credit points of electives from one of these areas.

The Graduate Diploma consists of the Graduate Certificate plus a further 24 credit points of electives. This means that in total the students will do 32 credit points of electives, of which 24 will be from one of the coherent streams on offer, and the remaining eight credit points may be chosen from any of the other electives. Most of these electives are existing graduate subjects within the relevant faculties.

The third component of the program for students progressing to the Master's will be the development of a multimedia product. Students will form multidisciplinary groups for this purpose. Supervision of the final product will be carried out by relevant staff in the faculties who have been identified as having a suitable background for each project.

Each student will plan an individual course based on the program below with the Academic Director of the program.

### Course structure

#### Graduate Certificate in Interactive Multimedia

**Core:**

xxxxx	Multimedia Industry and Process	8cp
xxxxx	Multimedia Products and Technology	8cp
	Elective	8cp

#### Graduate Diploma in Interactive Multimedia

**Graduate Certificate plus:**

Elective stream	24cp
-----------------	------

#### Master of Interactive Multimedia

**Graduate Diploma plus:**

Multidisciplinary team based project	24cp
--------------------------------------	------

The electives will be taken from a stream designed to complement the student's existing knowledge. Current streams are from:

#### School of Computing Sciences

These electives are to give students some basic technical skills:

31429	Procedural Programming	6cp
31436	Systems Software and Networks	8cp

31904	Systems Programming	6cp
31512	Networking 1	6cp
31513	Networking 2	6cp
31927	Applications Development with Visual Basic	6cp
31876	Operating Systems Facilities	
31862	Fundamentals of Human-Computer Interaction	6cp
31863	Human-Computer Interaction Tools and Techniques	6cp
31864	Implementation of Human-Computer Interaction	6cp
32106	Object-oriented Software Development	6cp
32307	Operating Systems	6cp
32501	Computer Graphics	6cp
32502	Advanced Computer Graphics Techniques	6cp
xxxxx	Text-Based Systems	6cp
32509	Human-Computer Interaction in Information Systems	6cp
32516	Internet Programming	6cp
32522	C for Systems Programmers	6cp

**Faculty of Design, Architecture and Building**

These subjects are mainly in the area of design, graphics and visual communication:

81021	Communication Technology	4cp
81925	3D Computer Animation 1	4cp
81030	3D Computer Animation 2	4cp
81024	Computer Graphics 1	4cp
81923	Introduction to Design Computing	8cp
82009	Human Factors and Design	4cp
82016	Graphic Visualisation	4cp
82017	2D and 3D Communication	4cp
82915	Photography for Designers	4cp

**Faculty of Engineering**

These subjects are all in hypermedia:

49031	Information Structures, Perception and User Interface Design	6cp
49241	Hypermedia Technologies	6cp
49242	Mono Media Technologies	6cp
49243	Design of Hypermedia Information Systems	6cp

**Faculty of Humanities and Social Sciences**

Note that the Faculty of Humanities and Social Sciences is in the process of re-designing its courses, so the following subjects may change:

**Information Studies stream**

55902	Information Behaviour	6cp
55906	Organisation of Information	6cp
55907	Information Retrieval	6cp
55903	Information Production and Presentation	6cp
55910	User Documentation 1	6cp
55911	User Documentation 2	6cp
54299	NetDesign	6cp

**Media Production stream**

54116	Audiovisual Media Production	6cp
54150	Computers and Print Production	6cp
54151	Computers and Audiovisual Production	6cp
50457	Theories of the Visual	6cp
51007	Media Studies	6cp
52272	Sound, Music, Noise	6cp
52274	Sound Studies	6cp
54295	Sound Design	8cp
54101	Sound and Image	6cp
54110	Media, Culture and Society	6cp
54153	Video Basic	4cp

**Admission requirements**

Applicants should have a first degree, equivalent to a three-year undergraduate degree from the University of Technology, Sydney and have two years of related work experience. Applicants are expected to demonstrate that they possess sound communication skills, analytical and critical skills, and knowledge of a specialty area related to the multimedia industry.

**Fees**

Full tuition fees will be charged for students in these programs. In 1998 the fee for the course has been set at \$250 per credit point (that is \$1500 per six credit point subject). All fees are subject to annual review.

**Exemptions**

Given the interdisciplinary focus and teamwork emphasis of these courses, advanced standing and subject exemptions will not normally be granted for postgraduate study or work experience.

## Master of Science in Internetworking

Course code: **MC80**

## Graduate Diploma in Internetworking

Course code: **MC81**

## Graduate Certificate in Internetworking

Course code: **MC82**

This is a set of articulated offerings:

- Graduate Certificate in Internetworking 18 cp
- Graduate Diploma in Internetworking 48 cp (30cp + Grad Cert)
- Master of Science in Internetworking 72 cp (24cp + Grad Dip)

Initially the courses will be offered as part-time study over one, two or three years. Should the demand warrant a full-time course, it may be possible to offer the Graduate Certificate, at least, over one semester full-time. It is anticipated that eventually the program will be offered in a very flexible mode. It is a fee paying course. While the program will be managed by the School of Computing Sciences, it is a joint program between the School and the telecommunications group in the Faculty of Engineering.

The program is designed to meet the growing needs of industry for networking specialists. It is intended for computing or engineering graduates with or without networking experience who wish to learn or extend their knowledge of networking. As it is anticipated that students will have a variety of backgrounds, there is a degree of subject choice in the program to meet an individual student's needs.

### Course structure

#### Graduate Certificate in Internetworking

32523	Operating Systems for Internetworking	6cp
32524	LANS and Routing	6cp
32522	C for Systems Programmers	6cp
	<i>or</i>	
31904	Systems Programming	6cp

#### Graduate Diploma in Internetworking

##### Graduate Certificate plus

32520	UNIX Systems Administration	6cp
32525	Distributed Software Programming	6cp
32521	Internetworking	6cp
32527	Internetwork Design	6cp

one elective chosen from

32516	Internet Programming	6cp
49201	Integrated Services Network	6cp
45668	Teletraffic Engineering	6cp
31920	Network Management	6cp
32510	Principles of Object-oriented Programming in C++	6cp

#### Master of Science in Internetworking

##### Graduate Diploma plus

32518	Internetworking Research	6cp
32519	Internetworking Project	18cp
	<i>or</i>	
32519	Internetworking Project plus an elective from the above list	12cp 6cp

**Note:** The subjects 32521 Internetworking; 32524 LANS and Routing; and 32527 Internetworking Design will enable students to obtain industry certification as well as a formal academic qualification.

### Admission requirements

Applicants should have a first degree, equivalent to a three-year undergraduate degree from the University of Technology, Sydney in the area of either Computing Science, Computer Systems Engineering or Telecommunications. There will be some non-graduate entry based on extensive industry experience.

### Fees

Full tuition fees will be charged for students in these programs. In 1998 the fee for the course has been set at \$250 per credit point (that is \$1500 per six credit point subject). All fees are subject to annual review.

### Exemptions

Where a student has previously studied material, it may be possible to gain advanced standing, or to substitute an elective subject.

## Graduate Diploma in Information Technology

**Course code:** MC52

The Graduate Diploma in Information Technology is intended to provide students with the basic knowledge and skills required for a professional career in the computing and/or information systems area. It is designed for people who have already taken a first degree in which computing has not been included, or only covered lightly.

It is anticipated that students entering the course will have previously studied courses from a wide range of disciplines. Some will have graduated with no previous contact with computing; for such, the course is essentially a re-training degree, aiming to lay the foundations for a new career in the computing and/or information systems area. Other students entering the course will have had some familiarisation with computing, while still others will be familiar with computing concepts in areas such as programming, systems analysis and information retrieval, and will be seeking to consolidate and extend their present knowledge by attaining a formal computing qualification. It is not intended that applicants have extensive computing experience, given the re-training emphasis of the course.

Satisfactory completion of the course leads to the award of Graduate Diploma in Information Technology. It is anticipated that holders of this award will be granted exemption from the Associate examinations of the Australian Computer Society.

### Admission requirements

The Graduate Diploma in Information Technology may be taken on a full- or part-time basis, with an intake in either Autumn or Spring semester.

Applicants should have a first degree, equivalent to an undergraduate three-year degree from the University of Technology, Sydney. Candidates who are unsure of the exact ranking of their degree should either contact the University Graduate School on 9514 1523, or write to the National Office of Overseas Skills Recognition, PO Box 25, Belconnen, ACT 2616.

The number of applicants for the Graduate Diploma is expected to be in excess of the number of places. In addition to the

Application for Admission to Graduate Coursework form, applicants should complete a Supplementary Application form, and support their application with whatever documentation they consider to be appropriate. The selection committee may invite some applicants in for an interview.

For further information, applicants should contact the Faculty's Graduate Administration Officer, on 9514 1806, or Peter Bebbington, Director, Graduate Education, on 9514 1828.

### Fees

In 1998 the fee for the course will be set at \$8,160 for 48 credit points (that is, \$170 per credit point) for Australian citizens and permanent residents. For international students, the fee will be set at \$13,000 per annum. All fees are subject to annual review.

### Attendance pattern

The course is normally taken on a part-time basis over two years, and will usually entail attending two to three evenings per week. Occasionally one afternoon per week (plus one to two evenings per week) may be required, depending on the choice of subjects. Some students may be unable to pursue the normal attendance pattern, or may wish, for some reason, to take longer to complete the course; this is allowable, but students must be aware of the University's maximum time rule which is described in the 'Progression rules' section below. The course may also be taken on a full-time basis over one year.

### Exemptions

Under normal circumstances, exemption from any core subject may be granted on the basis of equivalent study. A maximum of 12 credit points may be exempted. Students will **not** be granted exemption from elective subjects. The Graduate Certificate in Information Technology articulates into this course.

### Progression rules

All students enrolled in this course should be aware of the following University Rules under which a student's registration will be discontinued.

### Maximum time

Students will have their registration discontinued for failure to complete the course within four semesters from initial registration in the case of a full-time student, or within

eight semesters from initial registration in the case of a part-time student. This is not inclusive of periods of approved leave of absence (Rule 3.2.6.1).

### Unsatisfactory progress

Students will have their registration discontinued for any three failures in the course (unsatisfactory progress as defined by the Faculty Board resolution, FBMC/94/80) (Rule 3.2.6.2).

### Course structure

To gain the Graduate Diploma, students must complete a minimum of 48 credit points.

Students may commence either the full-time or part-time program in either semester.

### Recommended part-time program

#### Year 1

##### Semester 1

31414	Information Systems	6cp
31509	Computer Fundamentals	6cp

##### Semester 2

	Programming subject	6cp
31424	Systems Modelling	6cp

#### Year 2

##### Semester 3

31434	Database Design	6cp
31512	Networking 1	6cp

##### Semester 4

	Two Elective subjects from SoCS	12cp
--	---------------------------------	------

### Recommended full-time program

#### Semester 1

31414	Information Systems	6cp
31509	Computer Fundamentals	6cp
	Programming subject	6cp
31424	Systems Modelling	6cp

#### Semester 2

31434	Database Design	6cp
31512	Networking 1	6cp
	Two Elective subjects from SoCS	12cp

Notes: The programming subject may be one of:

- 31508 Programming Fundamentals
  - 31415 Principles of Software Development A
  - 31429 Procedural Programming
- according to student background and interest.

Electives may be taken from subjects offered in the undergraduate programs of the School of Computing Sciences (SoCS) for which the students have the prerequisites. Students will be required to discuss elective choices with the Director of Graduate Education.

The prerequisites for the core subjects are that Systems Modelling must be taken before Database Design and Computer Fundamentals must be taken before Networking 1.

All students are permitted to take any modules they wish from the subject 31417 Computing Practice. These modules, which will not be liable for fees, will be additional to the standard course program and credit will not be given.

## Graduate Certificate in Human-Computer Interaction

### Course code: MC65

This course is for students who wish to upgrade their professional qualifications. It provides students with the required knowledge of human-computer interaction and the practical skills that are necessary to effectively achieve better usability in the software and systems design and development process. The course focuses on HCI principles and techniques for improving usability aspects of software and systems, and on operational issues associated with implementing HCI in organisations. Students who are members of the Australian Computer Society will be credited with PCP points on completion of this certificate.

### Length and attendance pattern

The is a one-year part-time course that has a total of 18 credit points made up of three subjects, each worth six credit points.

Students attend one evening per week in the first semester and two evenings per week in the second semester. In the second semester, for the subject 31863 HCI Tools and Techniques, students attend two evenings a week for six weeks, followed by the subject 31864 Implementation of HCI, for which students attend two evenings a week for the following six weeks.

This pattern is important and follows a natural sequence which culminates in the final subject of the Graduate Certificate. The subject 31864 Implementation of HCI integrates what has been studied in the subjects 31862 Fundamentals of HCI and 31863 HCI Tools and Techniques. It also requires students to complete a practical HCI project on a topic of interest to them.

### Admission requirements

The course is intended for information industry professionals, and applicants should have both:

- a Bachelor's degree from UTS, or equivalent, preferably with a substantial information systems and/or computing component. Applicants whose degrees do not have a major information systems and/or computing component will be required to submit evidence to the effect

that the extent of their formal knowledge of computing is equivalent to that of a graduate from the University's Bachelor of Science in Computing Science;

and

- an established professional career within the information technology industry (as a guide, the extent of the applicant's professional experience should be equivalent to that of an Associate Member of the Australian Computer Society of at least two years' standing).

Consideration may be given to applicants whose backgrounds do not fit these requirements, provided that a case can be made to establish that their information systems and/or computing knowledge and practical experience are equivalent to the above.

### Course structure

The structure of the Graduate Certificate in Human-Computer Interaction is as follows:

#### Autumn semester

31862	Fundamentals of Human-Computer Interaction	6cp
-------	--------------------------------------------	-----

#### Spring semester

31863	Human-Computer Interaction Tools and Techniques	6cp
31864	Implementation of Human-Computer Interaction	6cp

For further information, contact Peter Bebbington, Director, Graduate Education, on 9514 1828.

### Maximum time rule

Students will have their registration discontinued for failure to complete the course in three semesters from the time of registration in the case of part-time students, not inclusive of periods of leave of absence (Rule 3.2.6.1).

### Unsatisfactory progress

Students will have their registration discontinued for any two failures in the course (unsatisfactory progress as defined by the Faculty Board resolution, FBMC/94/80) (Rule 3.2.6.2).

### Fees

Full tuition fees will be charged. In 1998, the fee for this course has been set at \$3,060. This fee is subject to annual review.



## Graduate Certificate in Information Technology

### Course code: MC67

The Graduate Certificate will be offered as a full fee paying part-time course usually extending over two semesters. It will consist of 18 credit points. It replaces all previous general Graduate Certificates and is designed to offer flexibility to the student. It articulates with the Graduate Diploma in Information Technology. Students who complete one Graduate Certificate will be able to carry the credit forward to the Graduate Diploma in Information Technology (GradDip (InfTech)).

Its aims are to provide opportunities for some computing practitioners to update their knowledge, to provide opportunities for graduates in other disciplines to commence study in Information Technology, and to provide flexibility for students in their study of computing subjects.

As explained above, the Graduate Certificate will consist of three 6 cp subjects, for a total of 18cp. Some combinations of subjects are shown below, with indications of expected times to complete. In addition, applicants will be able to choose other combinations from the undergraduate subjects offered by the School of Computing Sciences, subject to the approval of the Director of Graduate Education. Approval will involve consideration of such

aspects as prerequisite structures, subject timetables and the student's interest.

### Admission requirements

Applicants with a recognised Bachelor's degree (or equivalent) are normally deemed eligible for the course. Consideration may be given to applicants whose background does not fit this requirement, provided that a case can be made to establish that their aptitude, knowledge and practical experience are sufficient. Experience in the information technology industry is especially important in this regard.

### Maximum time rule

Students will have their registration discontinued for failure to complete the course in three semesters from the time of registration in the case of part-time students, not inclusive of periods of leave of absence (Rule 3.2.6.1).

### Unsatisfactory progress

Students will have their registration discontinued for any two failures in the course (unsatisfactory progress as defined by the Faculty Board resolution, FBMC/94/80) (Rule 3.2.6.2).

### Fees

Full tuition fees will be charged. In 1998, the fee for this course has been set at \$3,060 for 18 credit points.

Option	Subjects	Comments
A	31414 Information Systems 31424 Systems Modelling 31434 Database Design	Start Autumn or Spring, finish in one year
B	31511 System Design 31434 Database Design 31443 Distributed Database and Client/Server Computing	Start in Autumn, finish in one year
C	31510 Operating Systems 31512 Networking 1 31513 Networking 2	Start in Autumn, finish in one year
D	31509 Computer Fundamentals 31508 Programming Fundamentals 31414 Information Systems	Start Autumn or Spring, finish in one year
E	31508 Programming Fundamentals 31928 Applications Programming with Delphi 31931 Software Quality Assurance	Start in Autumn, finish in one year
F	31424 Systems Modelling 31511 System Design 31454 Project Management and the Professional <i>or</i> 31777 Human-Computer Interaction	Start in Autumn, finish in one year

# Subject descriptions

---

## Guide to subject descriptions

The subject descriptions shown below indicate the subject number and name, and the number of credit points for the subject (e.g. 6cp). For some subjects, there may also be practical components off-campus, and this is indicated in the text. Also shown are the prerequisites or corequisites, if any, the method of assessment and name of the subject coordinator, if known, and a brief outline of the content.

Prerequisites are subjects that must be completed before taking the subject to which they refer. Corequisites may be completed before or be taken concurrently with the subject to which they refer.

Subjects offered by the School of Computing Sciences are listed first, followed by those offered by other faculties.

Subjects offered by the School of Mathematical Sciences and those offered by the Institute for International Studies as part of the Bachelor of Science in Computing Science/Bachelor of Arts in International Studies can be found in the School of Mathematical Sciences' 'Subject descriptions' section in this handbook.

## 31140

### Introduction to Computer Graphics

*6cp; prerequisites: 31425 Principles of Software Development B; 31429 Procedural Programming or equivalent*

*subject coordinator: Dr K Suffern*

Provides a thorough introduction to the computer representation, manipulation and display of pictorial information. Topics covered include passive and interactive graphics, hardware devices and programming; mathematical tools for two- and three-dimensional graphics; two- and three-dimensional graphics and algorithms; graphics standards; human-computer interaction and graphical design; application areas of computer graphics.

## 31163

### Knowledge Technology

*6cp; prerequisites: 31425 Principles of Software Development B; 31429 Procedural Programming or equivalent*

*subject coordinator: Professor J Debenham*

Knowledge representation: state space graphs, And/Or graphs, productions, semantics nets, frames, logic. Inference. Search: various strategies. Uncertainty: probability, hypothetical reasoning, temporal logic, evidence, inference nets. Inexact reasoning: inference nets, certainty factors, Dempster-Shafer theory. Fuzzy logic, fuzzy sets.

## 31240

### Topics in Computer Graphics

*6cp; prerequisite: 31140 Introduction to Computer Graphics*

*subject coordinator: Dr K Suffern*

For students who have passed 31140, this subject provides a study of several additional computer graphics topics, with an emphasis on image synthesis techniques. Topics covered include fractals, illumination models, ray tracing, textures, anti-aliasing, half-toning and ordered dither, hidden line and surface removal algorithms, computer animation and radiosity.

## 31350

### Project (2 semesters)

*12cp; prerequisite: 31444 Systems Design and Development or equivalent*

*subject coordinator: Mr J Tu*

## 31351

### Project (1 semester)

*12cp; prerequisite: 31444 Systems Design and Development or equivalent*

*subject coordinator: Mr J Tu*

## 31352

### Project

*6cp; prerequisite: 31444 Systems Design and Development or equivalent*

*subject coordinator: Mr J Tu*

A project is intended to give a student experience in working independently, and responsibility for scientific research or the development of a small system from initial

analysis to user documentation. Projects may be drawn from any area of information technology. Each project is supervised by a member of academic staff.

### 31414

#### Information Systems

6cp

*subject coordinator: Mr C S Johnson*

This subject deals with information systems in their organisational context.

The effects of information systems on society, organisations and individuals are discussed. Examples from typical organisations are used to illustrate information systems concepts. Techniques for analysing and describing user requirements are introduced.

Throughout the subject there is an emphasis on human activities, the importance of the user in the analysis phase and the usability of systems. Another theme is communication skills i.e. the ability of the analyst and designer of an information system to interview, to write reports and manuals, to design efficient and effective interfaces, and to give presentations on the system.

### 31415

#### Principles of Software Development A

6cp; *corequisite: 31417 Computing Practice*

*subject coordinator: Dr R Rist*

The principles and practice of object-oriented software construction are introduced using the programming language Eiffel. Topics include the object-oriented concepts of classes, objects, clients and suppliers, inheritance, genericity, dynamic binding and polymorphism.

### 31416

#### Computer Systems Architecture

6cp

*subject coordinator: Mr CW Johnson*

This subject provides a sound basis for understanding how computer hardware and data communications support higher level software constructions. All software undergoes a process of translation or interpretation which reduces it to primitive operations capable of being performed by the 'hardware'. In this subject, these primitive operations, and the organisation and design of computer systems that execute these operations, are examined. The SPARC architecture, together with its assembly language, is studied as an example of a contemporary (and real) computer

architecture. This subject also presents some fundamental concepts in data communications, as a basis for later subjects which treat the topic in greater depth.

### 31417

#### Computing Practice

6cp

*subject coordinator: Mr J Colville*

Principles of responsible computer use. Computer skills: Touch typing. DOS commands. Microsoft Windows. The Macintosh environment. Introductory word processing, spreadsheets and graphics. The Unix environment, ftp, telnet, electronic mail. File conversions. Backups. Introductory library research skills. Introduction to report writing.

### 31424

#### Systems Modelling

6cp

*subject coordinator: Mr J El-Den*

This subject introduces information system concepts including their static and dynamic components. It describes how these concepts can be used to model information systems to correctly capture their structure and needs. It outlines how the ability to capture information about the system in ways understood by its eventual users will improve the final quality of the system.

The subject introduces analysis using various approaches found in contemporary system development, including object-oriented methods, data flow diagrams and Entity-Relationship modelling, and describes the relationships between these techniques and their application.

### 31425

#### Principles of Software Development B

6cp; *prerequisite: 31415 Principles of Software Development A*

*subject coordinator: Dr T Osborn*

The specification and implementation of stacks, queues, lists, and trees are discussed as abstract data types. Formal mathematical specification of software, and program correctness are discussed. Program testing methods are emphasised throughout the subject, as are aspects of software quality such as usability.

**31428****Quantitative Modelling**

6cp

*subject coordinator: Dr T Osborn*

Reasoning with data, descriptive statistics, probability theory, distributions, estimation, hypothesis testing, spreadsheet exercises, report writing, principles of modelling, queuing models, utility models, adaptive methods, and case studies of some basic models.

**31429****Procedural Programming**

6cp; prerequisite: 31415 Principles of Software Development A; corequisite: 31425 Principles of Software Development B

*subject coordinator: Dr B Howarth*

Top-down structured program design techniques, and their application to the development of commercial programming applications. Emphasis will be on quality and usability of the resultant systems. Debugging and testing skills are developed. The language used is C.

**31434****Database Design**

6cp; prerequisite: 31424 Systems Modelling or equivalent

*subject coordinator: Dr G Feuerlicht*

This subject introduces the students to basic database design and implementation concepts. Database design techniques including relational design and E-R analysis are presented. Database programming using SQL is covered in lectures and supported by practical exercises. Object database and distributed database concepts are introduced.

**31436****Systems Software and Networks**

8cp; prerequisites: 31425 Principles of Software Development B; 31429 Procedural Programming; 31416 Computer Systems Architecture or equivalent

*subject coordinator: Mr U Szewcow*

This subject builds on Computer Systems Architecture to provide an understanding of the operating system and communications hardware and software that provide support for user applications. Particular attention is paid to the role of systems software in distributed systems.

**31443****Distributed Databases and Client/Server Computing**

6cp; prerequisite: 31434 Database Design or equivalent

*subject coordinator: Dr G Feuerlicht*

This subject introduces the students to basic distributed databases and client/server concepts. The classical approach to distributed databases is described in detail, and supported with both theoretical and practical exercises. Modern client/server and database server techniques are introduced.

**31444****Systems Design and Development**

10cp; prerequisite: 31434 Database Design or equivalent; corequisite: 31436 Systems Software and Networks

*subject coordinator: Mr R Raban*

This is a project-based subject which guides students through an information systems development process. The requirements for the information system are specified in a series of Use Cases. The development involves designing the user interface and data system and then designing and implementing the system. The emphasis throughout the development is on meeting the user's requirements, implementing a distributed solution and integrating the new systems with the existing information systems infrastructure. Attention to quality of the system outcomes is maintained throughout the development process. Students will work in managed teams of 10. There are no formal lectures and no exams in this subject; staff/student contact takes place at regular structured project meetings and discussion meetings. Students are expected to have at least four hours of contact with their team each week and, given that this is a 10-credit-point subject, to do significant work outside of this contact time.

**31454****Project Management and the Professional**

8cp; prerequisites: 31444 Systems Design and Development; 31697 Industrial Training

*subject coordinator: Mr D Wilson*

This subject covers the management of the development and implementation of information technology solutions, with particular emphasis on information systems project management, managing software quality

assurance and the professional ethics of software developers.

### 31455

#### Software Development Case Study

10cp; prerequisite: 31444 *Systems Design and Development*

subject coordinator: Dr R Van der Meyden

In the first semester, lectures will run in two strands: one devoted to projects, and the other to automata theory and new theory and skills. Laboratories will work on the projects.

The major project will incorporate the following stages: modular decomposition of the system; development of interfaces to the user (GUIs), between modules, to class libraries, and to other applications (code-wrapping); coping with change of specifications; detailed coding; and verification, documentation and testing. This is a full-year subject.

### 31464

#### Information Technology Planning and Design

6cp; prerequisites: 31428 *Quantitative Modelling*; 31436 *Systems Software and Networks*; 31444 *Systems Design and Development*; 31454 *Project Management and the Professional*; 31697 *Industrial Training*

subject coordinator: Mr C S Johnson

This subject is a capstone subject for the course and incorporates knowledge gained in previous subjects, including industrial experience. Students are required to work in groups to produce a large report based on case study material. The objective is to produce a strategic solution to the problem presented in the case study involving both planning and design. The subject emulates the commercial environment in that students work in project groups and hold weekly project review meetings. A presentation to management occurs at the end of the subject.

### 31507

#### Australian Studies 2

6cp

subject coordinator: tba

An overview of information technology in Australia. Key market areas and current trends will be studied.

### 31508

#### Programming Fundamentals

6cp

subject coordinator: Mr J Underwood

Students learn programming concepts, and learn to write medium-size programs in an object-oriented language.

### 31509

#### Computer Fundamentals

6cp

subject coordinator: Mr CW Johnson

This subject introduces students to the internal organisation of the computer.

### 31510

#### Operating Systems

6cp

subject coordinator: Mr J Colville

This subject introduces students to modern operating systems, and shows how the systems support applications programs.

### 31511

#### Systems Design

6cp

subject coordinator: Mr R Raban

This subject gives students practical skills in designing medium-scale computer applications.

### 31512

#### Networking I

6cp

subject coordinator: tba

This subject introduces students to data communications concepts and provides detailed information about the physical and data link layers for several network types.

### 31513

#### Networking 2

6cp

subject coordinator: tba

This subject builds on the content of Networking 1 to introduce students to the operation of local area networks, network applications and control.

**31514****Computing Theory***6cp**subject coordinator: Professor J Debenham*

This subject introduces students to some of the theory underlying computing science. It includes such topics as formal methods and computational complexity.

**31654****Languages and Translators**

*4cp; prerequisites: 31416 Computer Systems Architecture; 31425 Principles of Software Development B; 31429 Procedural Programming or equivalent*

*subject coordinator: Mr J Colville*

Translation and execution of expressions and statements. Syntactic analysis and parsing. Attribute grammars. Compile-time type checking. Syntax and table-driven compilers. Compiler-compilers. Code generation, error diagnostics and error correction of code. Code optimisation. Memory allocation during compilation and execution.

**31696****Industrial Training (F/T)**

*Ocp; prerequisites: 31414 Information Systems; 31415 Principles of Software Development A; 31416 Computer Systems Architecture; 31417 Computing Practice; 31424 Systems Modelling; 31429 Procedural Programming; 31434 Database Design; 31436 Systems Software and Networks or equivalent*

*subject coordinator: Mr J Underwood*

For subject details see 31697 Industrial Training (F/T).

**31697****Industrial Training (F/T)**

*Ocp; prerequisite: 31696 Industrial Training (F/T) (first semester)*

*subject coordinator: Mr J Underwood*

The first and second semesters of Industrial Training are a compulsory requirement for the course. All full-time students must enrol in these subjects and obtain a minimum of nine months of full-time employment. Students must normally have completed the equivalent of at least four full-time semesters before obtaining employment.

**31698****Industrial Training (P/T)***Ocp; prerequisites: see 31696**subject coordinator: Mr J Underwood*

For subject details see 31699 Industrial Training (P/T).

**31699****Industrial Training (P/T)**

*Ocp; prerequisite: 31698 Industrial Training (P/T) (first semester)*

*subject coordinator: Mr J Underwood*

The first and second years' Industrial Training are a compulsory requirement for the course, normally taken for a total of four semesters in Stages 5 and 6. All part-time students must enrol in these subjects and obtain a minimum of 18 months of full-time employment.

**31718****Contemporary Information Technology I***6cp**subject coordinator: Mr D Wilson*

This is a self-paced learning subject that provides basic skills that students will use in a variety of other subjects and in industry – skills include word processing, spreadsheets, graphics, email etc. The self-paced learning will be complemented by lectures from partner organisations about the industry and the first industry semester.

**31722****Commercial Programming**

*5cp; prerequisites: 31414 Information Systems; 31415 Principles of Software Development A*

*subject coordinator: Mr J El-Den*

Commercial structured design techniques and commercial programming in either a batch or online environment. Students will be taught the design technique and language of the particular industry organisation using approved assignment work.

**31735****Information Systems and Organisation Development**

6cp

*subject coordinator: Mr J Underwood*

This subject introduces theories dealing with the behaviour of people in organisations, the structure of organisations, and the relation between the two. Systems thinking is used to bring these views together as a basis for organisation development in an environment changing through the influence of information systems.

**31737****Business Process Transformation**

4cp

*subject coordinator: Mr J Underwood*

This subject covers the restructuring of organisational processes through the innovative use of information systems and information technology. Current proposals for organisation restructuring are introduced and evaluated through comparison with previous theories of restructuring.

**31743****Machine Learning**

6cp; prerequisite: 31428 Quantitative Modelling

*subject coordinator: Dr T Osborn*

This subject is concerned primarily with Machine Learning: automatic construction of computable models from data. Symbolic and non-symbolic methods are studied. Topics include statistical learning, clustering and correlations; neural networks methods; genetic algorithms; genetic programming; Shannon information; rule induction; and first-order learning.

**31744****Case-based Reasoning**

6cp; prerequisite: 31163 Knowledge Technology

*subject coordinator: Dr R Rist*

This subject builds on fundamental work in knowledge technology and introduces students to the concepts of case-based reasoning. Neural architecture, human memory. Semantic nets. Memory indexing. Case-based reasoning: case finding, case evaluation, case adaptation, building a case base. Planning: adaptation, correctness. Case-based planning. Expectations. Explanation-based learning.

**31745****Knowledge-based Systems**

6cp; prerequisite: 31743 Machine Learning or 31744 Case-based Reasoning

*subject coordinator: Dr S Prabhakar*

This subject addresses the important issues relating to the design of flexible Knowledge-Based Systems (KBS). These include understanding analytical techniques for KBS, bases for deep level representation of the world, knowledge acquisition techniques, design principles and case studies of how these principles are implemented in the current KBS.

**31746****Artificial Intelligence Applications**

6cp; prerequisite: 31743 Machine Learning or 31744 Case-based Reasoning

*subject coordinator: Dr S Prabhakar*

This subject builds on fundamental work in knowledge technology and introduces students to issues in building a substantial artificial intelligence system. Use of artificial intelligence languages. Knowledge acquisition. Application selection. Knowledge engineering, computer assisted knowledge engineering. Designing for maintainability. Truth maintenance systems. Review of artificial intelligence applications.

**31748****Programming on the Internet**

6cp; prerequisite: 31436 Systems Software and Networks

*subject coordinator: Mr N Hamilton*

This subject covers programming in Java, website administration, HTML authoring, CGI programming and network security.

**31749****Internet Commerce**

6cp

*subject coordinator: Mrs E Lawrence*

This subject aims to give students exposure to internet commerce and will develop an understanding of the stakeholders and their capabilities and limitations in the strategic convergence of technology and business. Topics will include business models for internet commerce, security, legal and ethical issues. Students will develop skills in identifying the advantages and disadvantages of the various electronic payment options. Students will complete computer based activities on internet commerce.

**31756****Project Management**

*5cp; prerequisite: 31788 Organisation Theory for IT Professionals*

*subject coordinator: Mr D Wilson*

Provides students with the practical knowledge and skills that are necessary to effectively manage project teams and software development projects. The major topics are: planning a software project, software time and cost estimation, controlling a software project, development aids and alternatives, leadership and people management. This subject will provide an essential understanding of project management issues and identify the knowledge required of a project manager in the IT industry.

**31764****Information Technology Strategy**

*4cp*

*subject coordinator: Mr D Wilson*

This subject provides students with an awareness of the problems in developing corporate strategies, in general, and information strategies, in particular. It also develops skills in the selection and use of appropriate strategic planning techniques.

**31769****Contemporary Information Technology 2**

*4cp; prerequisite: 31718 Contemporary Information Technology 1*

*subject coordinator: Mr D Wilson*

This subject covers topical issues in the development and implementation of information systems and the professional ethics of software developers.

**31770****Industry Project I**

*5cp*

*subject coordinator: Mr B Wong*

Provides students with an understanding of the function of the Information Systems Department in an organisation and also of at least one user business function serviced by IS. Understanding is developed through a number of strategies such as interviewing, observation and work experience. Students will be taught human communication skills in conjunction with the project work, with special emphasis on oral and written communication. Training will also be provided in a variety of

development tools used in the information systems development process in order to build up a defined skills profile in conjunction with the subject 31790 Industry Project 2.

**31771****Business Requirements Analysis**

*5cp; prerequisite: 31414 Information Systems*

*subject coordinator: Mr J Clark*

Applications of systems analysis (data flow diagrams, relational modelling etc.) in a business setting; the roles of the business analyst and the systems analyst; systems research and requirements analysis (interviewing, document analysis etc.) for data processing, management information systems etc. top-down enterprise-wide perspective; evolution of the business environment; business, product and other life cycles. Industry case studies.

**31777****Human-Computer Interaction**

*6cp; prerequisite: 31444 Systems Design and Development or equivalent*

*subject coordinator: Ms J Hammond*

Focuses on human factors and information systems aspects of user-centred systems development and design. Provides students with HCI principles, concepts, tools and techniques needed to build user-centred systems, particularly in terms of the design of interfaces that satisfy user needs and create usable products that support user tasks and goals. Major topics include the role and scope of HCI, HCI methods such as requirements analysis, task analysis and usability testing, usability evaluation, and user-centred design support.

**31778****Resources Management for IT Professionals**

*4cp*

*subject coordinator: Mr D Wilson*

Aims to instil the knowledge and skills required for effective management of hardware and software resources within an information system organisation. The major topics include resource acquisition, developing software, workplace environments, hardware and software security, operations management, and EDP accounting.



**31779****Applications of Information Technology 1**

*5cp; prerequisite: 31414 Information Systems*  
*subject coordinator: Mr C S Johnson*

Formal and practical exposure to, and understanding of, a variety of specific applications of information technology, such as management information systems, databases, decision support systems, process control, graphics etc. Subject material will complement that of 31789 Applications of Information Technology 2 to ensure a common level of experience for all students. This is an industry subject for BInfTech.

**31781****Business Systems Design**

*5cp; prerequisite: 31424 Systems Modelling or 31641 Systems Design*  
*subject coordinator: Mr J Underwood*

Understanding systems design in a business setting; performance and quality criteria; alternative implementation strategies; approaches to systems construction and estimation (including package evaluation and prototyping); implementation issues; productivity issues; methods engineering; information technology in business; industry and product differences. Case studies. This is an industry subject for BInfTech.

**31789****Applications of Information Technology 2**

*5cp; prerequisite: 31779 Applications of Information Technology 1*  
*subject coordinator: Mr C S Johnson*

Formal and practical exposure to, and understanding of, a variety of specific applications of information technology, such as management information systems, databases, decision support systems, process control, graphics etc. Subject material will complement that of 31779 Applications of Information Technology 1 to ensure a common level of experience for all students.

**31790****Industry Project 2**

*5cp; prerequisite: 31770 Industry Project 1*  
*subject coordinator: Mr B Wong*

Students gain practical 'hands-on' experience of the role of members of an information systems development team in relation to

business organisational goals and objectives; students are incorporated as members of a project team in a sponsoring company. Training will also be provided in a variety of development tools in order to build up a defined skills profile in conjunction with the subject 31770 Industry Project 1.

**31860****Object-oriented Programming and C++**

*6cp; prerequisites: 31424 Systems Modelling; 31429 Procedural Programming or equivalent*  
*subject coordinator: Dr K Suffern*

Introduces C++ as a language to implement object-oriented programming. The subject covers objects, classes, inheritance, polymorphism and memory management in C++. Students will build upon their object-oriented experience in Eiffel, and their syntax knowledge of C.

**31862****Fundamentals of Human-Computer Interaction**

*6cp*  
*subject coordinator: Ms J Hammond*

Introduces students to the fundamental knowledge required to understand the nature and scope of HCI, the contribution to HCI of human factors, language and communication, and ergonomics, and the role of HCI in the software and systems design and development process. Approaches to incorporate HCI into the software design and systems development process will be examined with an emphasis on how HCI can ensure more usable software and systems.

**31863****Human-Computer Interaction Tools and Techniques**

*6cp; prerequisite: 31862 Fundamentals of Human-Computer Interaction*  
*subject coordinator: Ms J Hammond*

Introduces students to the knowledge and skills required to use a variety of HCI tools and techniques used in different phases of the software design and systems development process, and to use methods and metrics for evaluating the usability of software and systems. The role of usability guidelines and standards in the systems design process is examined.

**31864****Implementation of Human–Computer Interaction**

*6cp; prerequisite: 31862 Fundamentals of Human–Computer Interaction; corequisite: 31863 Human–Computer Interaction Tools and Techniques*

*subject coordinator: Ms J Hammond*

Provides students with the knowledge and practical skills to implement HCI approaches in the software and systems design and development process and integrate them into organisational and business contexts. Students undertake a substantial project to gain practical experience of how HCI can be implemented, and how usability can be measured through testing and evaluation. The implementation of usability guidelines and standards in conjunction with industry-wide quality assurance standards is examined.

**31875****Parallel Programming**

*4cp; prerequisites: 31429 Procedural Programming; 31436 Systems Software and Networks or equivalent*

*subject coordinator: Mr J Tu*

An introduction to parallel programming covering the following topics: a parallel programming language and program development system; modularising a problem into a set of cooperating sequential processes running in parallel; the prevention of deadlock; orderly termination of a set of parallel processes; use of multiple intercommunication processors; and comparison of performance under different physical configurations.

**31876****Operating Systems Facilities**

*6cp; prerequisites: 31429 Procedural Programming; 31436 Systems Software and Networks or equivalent*

*subject coordinator: Dr B Howarth*

The development of applications to make use of the facilities offered by an operating system offering support for a graphical user interface, such as Microsoft Windows or Macintosh, will be covered. Included is the methodology involved in building applications that are driven by user actions such as the mouse as well as input from a keyboard. Issues related to inter-application communication will also be explored.

**31894****Project**

*6cp; prerequisite: 31444 Systems Design and Development*

*subject coordinator: Mr J Tu*

A project is intended to give a student experience in working independently and responsibility for scientific research or the development of a small system from initial analysis to user documentation. Projects may be drawn from any area of computer science or information systems. Each project is supervised by a member of academic staff.

**31902****Auditing the Computer**

*4cp; prerequisite: 22615 Accounting Information Systems*

*subject coordinator: Mr J Clark*

Audit concepts and techniques in the EDP audit field. Control measures that must be embedded in computer accounting and information systems. Different systems of control, administrative, operational and security. Audit techniques and the DP audit function. Risk analysis, quality assurance.

The emphasis is oriented to control measures possible and desirable in various computer systems e.g. billing, creditors, payroll etc. and non-monetary information systems.

**31904****Systems Programming**

*6cp; prerequisite: 31429 Procedural Programming*

*subject coordinator: Mr U Szewcow*

This subject enhances the student's C and UNIX system knowledge. The student learns advanced C features, UNIX system calls, system utilities, shell and perl programming.

**31917****Commercial Programming**

*4cp; prerequisite: 31429 Procedural Programming or equivalent*

*subject coordinator: Mr J El-Den*

Top-down structured program design techniques, and their application to the development of commercial programming applications. Emphasis will be on quality and usability of the resultant systems. Debugging and testing skills will be developed. The language used will be COBOL.

**31919****Distributed Software Programming**

*6cp; prerequisites: 31436 Systems Software and Networks or equivalent; and 31904 Systems Programming or equivalent*

*subject coordinator: Mr U Szewcow*

This subject builds on material learned in Systems Software and Networks and Systems Programming. Students apply the knowledge and skills obtained in those subjects to explore the design and construction of Distributed Software Applications. Skills in the use of network communication libraries, thread and RPC libraries are developed. At the present time the C language and the UNIX environment are used.

**31920****Network Management**

*6cp; prerequisite: 31436 Systems Software and Networks*

*subject coordinator: Mr J Colville*

Instruction in network concepts, and the concepts and practical issues of network management. Students will have access to a laboratory where aspects of network management can be tried out in a practical way.

**31921****Objectbases**

*6cp; prerequisite: 31434 Database Design or equivalent*

*subject coordinator: Dr G Feuerlicht*

This subject introduces the students to OODB concepts. We review the basic OO principles and discuss their application to databases. The theoretical discussion of the topic will be supported with practical exercises using a commercially available OODBMS.

**31922****Object-oriented Methodologies**

*6cp; prerequisite: 31424 Systems Modelling or equivalent*

*subject coordinator: Mr R Raban*

This subject introduces the object-oriented methods of analysing the problem domain and creating an implementation independent formal representation of the system requirements. As elements of the object-oriented analysis (OOA) process, OOA representation and OOA complexity management are introduced and compared with the related concepts of structured analysis methodologies. The

differences between the two approaches, and the advantages and disadvantages of each of them, are discussed. Various object-oriented modelling methodologies are compared and their applicability to different application domains is assessed. The transition from implementation-independent results of the OOA to the object-oriented design (OOD) for different implementation platforms is also covered.

**31924****Performance Modelling**

*6cp; prerequisites: 31432 Systems Software and Networks; 31428 Quantitative Modelling; 31696–7 or 31698–9 Industrial Training*

*subject coordinator: Dr B Howarth*

This subject teaches concepts and practice of mathematical modelling for discrete-event systems. Students will gain experience in applying queuing theory models and discrete-event simulations to computer systems, and analysing the results. An important application of modelling is capacity planning, and students will be introduced to this topic.

**31925****Smalltalk**

*6cp; prerequisites: 31415 Principles of Software Development A; 31424 Systems Modelling or equivalent*

*subject coordinator: Dr S Prabhakar*

This subject provides an introduction to the Smalltalk programming language and environment. Topics include the syntax and semantics of Smalltalk, the Smalltalk programming tools, the Smalltalk class library, Smalltalk programming style and design, and adding graphical interfaces to Smalltalk programs.

**31926****Paradigms of Intelligence**

*4cp*

*subject coordinator: Dr R Rist*

Topics include fundamental issues in modelling intelligent behaviour; intentionality and knowledge-level; intelligent system as a problem solver; intelligence as adaptation and evolution; intelligence as belief revision; intelligence as an interaction with environment; memory and analogical reasoning; intelligent systems as learning systems; modelling the external world and the user environment; and psychological, philosophical, computational and scientific issues in modelling intelligence.

**31927****Applications Development with Visual Basic**

*4cp; prerequisites: 31414 Information Systems and one of 31415 Principles of Software Development A or 31429 Procedural Programming or 31729 Information Systems Practice; corequisite: 31424 Systems Modelling or 31434 Database Design*

*subject coordinator: Mr J Underwood*

This subject introduces event-driven programming. Students will learn Visual Basic and use it to build an interactive system. The system will be designed using dialogue oriented prototyping. Students will also learn to connect to various application packages using OLE.

**31928****Applications Development with Delphi**

*4cp; prerequisites: 31414 Information Systems and one of 31415 Principles of Software Development A or 31429 Procedural Programming or 31729 Information Systems Practice; corequisite: 31424 Systems Modelling or 31434 Database Design*

*subject coordinator: Mr P Bebbington*

This subject aims to give students exposure to the development of user-orientated databases using visual programming languages. Students will be required to apply software tools and packages which have different strengths and weaknesses to create an application. The technical environment for this subject is Borland Delphi and a database package.

**31931****Software Quality Assurance**

*6cp; prerequisite: 31424 Systems Modelling or equivalent*

*subject coordinator: Mr C S Johnson*

Aims to provide students with the practical knowledge and skills that are necessary to effectively measure and control the quality of software products. Major topics are quality assurance principles, quality metrics, verification, validation and testing, implementing quality assurance, and software engineering methods and tools.

**31945****Introduction to Computing Research**

*6cp*

*subject coordinator: tba*

This subject introduces Honours students to the nature of computing research, and some of the techniques used in various areas of computing research.

**31946****The Computing Literature**

*6cp*

*subject coordinator: tba*

This subject introduces students to the range of literature available in computing and information systems, and teaches students how to use the literature for research purposes.

**31947****Honours Research Project**

*24cp*

*subject coordinator: tba*

**31948****Honours Seminar 1**

*6cp*

*subject coordinator: tba*

Students will combine self-directed study and tutorial sessions to extend their knowledge about a particular area of information technology.

**31949****Honours Seminar 2**

*6cp*

*subject coordinator: tba*

Students will combine self-directed study and tutorial sessions to extend their knowledge about a particular area of information technology.

**31950****Networked Enterprise Design**

*6cp*

*subject coordinator: Professor I Hawryszkiewicz*

This subject describes evolution of systems towards distributed environments with more emphasis on working together over distance. It describes how people work together and the changes to work practices resulting from the distribution of such work, including telework and mobile workers. The subject covers collaboration technologies such as email, video-conferencing, co-authoring and

workflows, needed to support distributed work. The subject emphasises the design process, describing how to choose and implement collaborative technologies based on systems such as World Wide Web or Lotus Notes to meet the needs of distributed groups both across organisations as well as using Intranets within organisations.

### 32106

#### Object-oriented Software Development

6cp

*subject coordinator: Mr R Raban*

Basic principles of object-oriented software development. Classes as modules and classes as types. OO analysis and design. Software design as object modelling through abstract data type definition. Design by contract and subcontracting. The different forms of inheritance. OO programming. Static vs. dynamic typing; static vs. dynamic binding. Comparison of OO programming languages. Software development environments. Support for OO methods and techniques. OO models of the software development process. Project management for OO. Designing for reusability. Abstraction and generalisation. Models of application domains as the basis for OO frameworks for fast application development.

### 32107

#### Formal Reasoning for Software Development

6cp

*subject coordinator: Dr R van der Meyden*

This subject promotes a methodology where correctness is established before efficiency is considered. Specification languages allow the precise description of systems, while abstracting away from implementation concerns. Formal refinement allows programs to be developed from specifications, while preserving correctness. Semantics of languages provide a basis for reasoning about their correct implementation. Reasoning about concurrency is difficult; formal models of concurrency will be introduced.

### 32108

#### Specialist Topics in Artificial Intelligence

6cp

*subject coordinator: Professor J Debenham*

This subject covers some important areas of artificial intelligence and their applications. These areas include, broadly, knowledge representation, problem solving, planning, knowledge-based systems, dealing with uncertainty, explanation facilities, machine learning, and applications of AI. The subject quickly introduces students to the basic AI techniques and then deals with individual topics in-depth. The subject may specialise in one or more sub-areas of AI.

### 32204

#### Advanced Data Management

6cp

*subject coordinator: Dr G Feuerlicht*

This subject covers a range of advanced database topics, including: relational, object-oriented database systems and distributed databases. The subject area is treated mainly from a technological viewpoint, but also includes discussions of management issues.

### 32205

#### Computer Communication Systems

6cp

*subject coordinator: Professor M Fry*

Historical evolution. Architectural models. Standards. Requirements analysis and specification. Principles of design. Regulatory environment. Inter-organisational computer communications. Computer communications existing and emerging technologies. Integrated broadband networks. Computer communications management.

### 32206

#### Advanced Information Systems Modelling

6cp

*subject coordinator: Mr R Raban*

Information systems requirements can be modelled in many different ways. The modelling method used should be suitable to the class of the system. The modelling methods differ in terms of their expressive power and ability to describe requirements in specific application domains. This subject presents and compares the information systems modelling methods used in structured and object-

oriented methodologies. Formal and de facto industry standards for modelling information systems are also covered.

### 32207

#### Information Management

6cp

*subject coordinator: Mr P Bebbington*

This subject covers three broad topics: management of the information resources of an organisation, management of the development and maintenance of systems using those resources, and management of IT personnel and users of the information resources. Management of information resources requires the calculation of the costs and benefits of such resources, both in accounting and qualitative terms, and the controlling and recovering of costs so that services can be used in an efficient and effective manner. It also includes the security, privacy and legal matters which are part of data management. Management of system development and maintenance includes project management and control, systems development methodologies and tools, and IT organisation structures. The emphasis in IT personnel and client relationship management is on the effective use of IT staff in an increasingly user-oriented world.

### 32208

#### Information Processing Strategy

6cp; *prerequisite: 32207 Information Management*

*subject coordinator: Mr D Wilson*

This subject is designed to provide students with an awareness of the problems in developing corporate strategies for information processing and to develop skills in the selection and use of appropriate techniques.

### 32306

#### Capacity Management

6cp

*subject coordinator: Dr B Howarth*

Introduces students to the concept of capacity management, and relates this management tool to the broader management areas of corporate planning and systems development.

### 32307

#### Operating Systems

6cp

*subject coordinator: Dr B Howarth*

Topics in modern operating systems: concurrency in multiprocessor operating systems, programming support environments, user-friendly system interfaces, object-based systems, fault tolerant systems, and secure systems.

### 32308

#### Computer Architecture

6cp

*subject coordinator: Associate Professor T Hintz*

Current directions in machine architecture, and the relationship between machine architecture, task structure and system performance.

### 32402

#### Information Technology Environment

6cp

*subject coordinator: Mr J Underwood*

This subject deals with trends and issues in the management of IT. Typical issues are: IT within the company – user and expert cultures; competition vs. collaboration in the IT industry; relations between suppliers and customers; hardware manufacturers and software houses; downsizing and outsourcing; encouraging innovation; IT as a global industry; social impacts of IT; employment effects; and IT as a leading part of the economy.

### 32501

#### Computer Graphics

6cp

*subject coordinator: Dr K Suffern*

Demonstrates why computer graphics are important and, through the lectures and practical work, gives students a working knowledge of elementary two- and three-dimensional graphics programming algorithms.

### 32502

#### Advanced Computer Graphics Techniques

6cp; *prerequisite: 32501 Computer Graphics*

*subject coordinator: Dr K Suffern*

Gives students a working knowledge of ray tracing, which is one of the two major image synthesis techniques. It also gives students practical experience with a commercial rendering and animation package.

**32503****Distributed Databases and Client/Server Computing**

6cp

*subject coordinator: Dr G Feuerlicht*

This subject covers a range of topics in distributed databases and client/server computing. The main topics include discussion of distributed database design, distributed transactions and queries, and data replication strategies. Modern client/server and database server techniques are introduced.

**32504****Tool-based Systems Development**

6cp

*subject coordinator: Dr G Feuerlicht*

The current industry trend is away from the traditional programming-oriented approach towards a tool-based approach to system analysis and development. Central to this approach is the use of repositories to define and maintain information about application systems and the use of tools to develop applications. This elective subject focuses on system development methodologies and techniques and the use of commercially available tools for systems development.

**32508****Software Quality Management Systems**

6cp

*subject coordinator: Mr C S Johnson*

Provides students with the practical knowledge and skills necessary to manage the quality of software products. It will provide an essential understanding of software quality management, which is a key strategy in enabling the Australian IT industry to compete both nationally and internationally.

**32509****Human-Computer Interaction in Information Systems**

6cp

*subject coordinator: Ms J Hammond*

Provides students with an understanding of the principles, concepts, tools and techniques needed to manage the development of information systems from a human-computer interaction perspective. Usability is considered throughout information systems development from initial systems concepts to implementation.

**32510****Principles of Object-oriented Programming in C++**6cp; *prerequisite: 32106 Object-oriented Software Development**subject coordinator: Dr K Suffern*

Review of object-oriented design principles and practice. Objects, classes, run-time instantiation, inheritance, information hiding, polymorphism and libraries and their implementation in C++.

**32511****Principles of Object-oriented Programming in Smalltalk**6cp; *prerequisite: 32106 Object-oriented Software Development**subject coordinator: Dr S Prabhakar*

The Smalltalk language and programming environment are covered in the first half of the subject. The second half uses the Smalltalk class library to build an interactive system with a graphical user interface (GUI).

**32512****Advanced Knowledge Technology**

6cp

*subject coordinator: Professor J Debenham*

Knowledge representations: state space graphs, And/Or graphs, productions, semantic nets, frames, logic. Inference. Search: various strategies. Uncertainty: probability, hypothetical reasoning, temporal logic, evidence, inference nets. Inexact reasoning: inference nets, certainty factors, Dempster-Shafer theory. Fuzzy logic, fuzzy sets.

**32513****Advanced Machine Learning**6cp; *prerequisite: 32512 Advanced Knowledge Technology**subject coordinator: Dr T Osborn*

This subject is concerned primarily with machine learning: automatic construction of computable models from data. Symbolic and non-symbolic methods are studied. Topics include statistical learning, clustering and correlations; neural networks methods; genetic algorithms; genetic programming; Shannon information; rule induction; and first-order learning.

**32514****Advanced Case-based Reasoning**

*6cp; prerequisite: 32512 Advanced Knowledge Technology*

*subject coordinator: Dr T Osborn*

Neural architecture, human memory. Semantic nets. Memory indexing. Case-based reasoning: case finding, case evaluation, case adaptation, building a case base. Planning: adaptation, correctness. Case-based planning. Expectations. Explanation-based learning.

**32516****Internet Programming**

*6cp*

*subject coordinator: Mr N Hamilton*

Internet Programming covers programming in Java, web site administration, HTML authoring, CGI programming and network security. Students implement a system, preferably in their work environment, that interfaces a database to the World Wide Web using Java.

**32517****Commerce on the Internet**

*6cp*

*subject coordinator: Mrs E Lawrence*

This subject aims to give students exposure to internet commerce and will develop an understanding of the stakeholders and their capabilities and limitations in the strategic convergence of technology and business. Topics will include business models for internet commerce, security, legal and ethical issues. Students will develop skills in identifying the advantages and disadvantages of the various electronic payment options. Students will complete computer based activities on internet commerce.

**32518****Internetworking Research**

*6cp*

*subject coordinator: tba*

Students will conduct supervised research on a topic in internetworking, and prepare a research report.

**32519****Internetworking Project**

*18cp*

*subject coordinator: tba*

Students will undertake a large group project in an area of internetworking. They will also prepare a project report.

**32520****UNIX Systems Administration**

*6cp*

*subject coordinator: tba*

Students will learn about basic UNIX Systems administration, including: registering users, file systems, networking, performance management. Students will be presumed to be competent users of UNIX. There will be a laboratory component to the subject.

**32521****Internetworking**

*6cp*

*subject coordinator: tba*

This subject extends the principles studied in 32524 LANs and Routing by examining the issues associated with internetworking within autonomous systems and between autonomous systems. Scalable routing protocols and multi-protocol routers are dealt with as are the implications of multimedia for networks.

**32522****C for Systems Programmers**

*6cp*

*subject coordinator: Mr U Szewcow*

This subject develops skills in programming C with an emphasis on low level commands.

**32523****Operating Systems for Internetworking**

*6cp*

*subject coordinator: tba*

This subject looks at the principles of operating systems and the fundamental differences between systems currently used in internetworking such as UNIX and NT.

**32524****LANs and Routing**

*6cp*

*subject coordinator: tba*

This subject examines the issues associated with local area networks and their interconnection to other local area networks. It also introduces ideas associated with connection for remote or mobile users and connection to external networks.



**32525**

**Distributed Software Programming**

6cp

*subject coordinator: Mr U Szewcow*

This subject builds on material learnt in Operating Systems. It furthers an understanding of the underlying technology for implementing distributed systems software. Students design and develop distributed applications.

**32526**

**Designing the Networked Enterprise**

6cp

*subject coordinator: Professor I Hawryskiewicz*

The subject describes evolution of systems towards distributed environments with more emphasis on working together over distance. It describes how people work together and the changes to work practices resulting from the distribution of such work, including telework and mobile workers. The subject covers collaboration technologies such as email, video-conferencing, co-authoring and workflows, needed to support distributed work. The subject emphasises the design process, describing how to choose and implement collaborative technologies based on systems such as World Wide Web or Lotus Notes to meet the needs of distributed groups both across organisations as well as using Intranets within organisations.

**32527**

**Internetwork Design**

6cp

*subject coordinator: tba*

This subject combines the principles studied in LANs and Routing and Internetworking and extends them. These are then applied to the design of internetworks.

**32601**

**Advanced Project Management**

6cp

*subject coordinator: Mr D Wilson*

Provides an essential understanding of advanced project management issues and identifies the knowledge required of a project manager in the information technology industry.

**32602**

**Impact of Information Technology**

6cp

*subject coordinator: Mr D Wilson*

Reviews the effect of the introduction of computer technology into workplaces, improved efficiency of work organisations, increased occupational health hazards for computer terminal operators, and increased potential for computer crimes. Physical, psychological and environmental factors that contribute significantly to conditions such as RSI are explained in depth. The effects of information technology on employment patterns are examined. Computer crime is defined and categorised and the difficulties associated with its prevention and detection, and with subsequent legal actions, are discussed. Measures to ensure the protection of privacy are explained in this unit.

**32603**

**Software Quality Management**

6cp

*subject coordinator: Mr D Wilson*

Provides the students with the practical knowledge and skills necessary to manage the quality of software products.

**32604**

**Systems Integration**

6cp; prerequisite: 32601 Advanced Project Management

*subject coordinator: to be advised*

Systems integration can be defined as the business of adding value to a specific project, by assuming responsibility for combining information products and services into a specified business solution. The system integrator takes the responsibility and risk for the project. This subject examines the project from the set of user requirements right through to the final output solution, delivered on time, within budget and having achieved the expected performance criteria.

**32605**

**Managerial Analysis and Evaluation of Information Systems**

6cp

*subject coordinator: Mr B Wong*

Presents a range of fundamental accounting, risk analysis and performance criteria for information systems. This subject is intended

to provide basic skills in evaluating computer-based information systems. For students who are involved in management, it is important that they are aware of what information systems can provide and how to rate them and how to specify their requirements for their organisation's advantage.

### 32701

#### Advances in Information Technology

6cp

*subject coordinator: to be advised*

Looks at the technology trends affecting information processing and delivery, to provide the student with the vision to ensure that not only is their company well served in the present by its technology environment, but that it is also able to take up the opportunities of the future.

### 32702

#### Contemporary Telecommunications

6cp

*subject coordinator: Professor M Fry*

Introduction to data communications and networks. Network architecture and standards. New communications technologies. Internetworking. Domestic and international communications environment. Application-oriented services. Network resource architectures. Client/server systems. Introduction to distributed processing. Distributed databases. Emerging technologies. Business and telecommunications planning.

### 32703

#### Information Technology Strategy

6cp

*subject coordinator: Professor L Constantine*

Designed to provide students with an awareness of the problems in developing corporate strategies for information processing, and to develop students' skills in the selection and use of appropriate techniques.

### 32704

#### Strategic IT Contract Management

6cp

*subject coordinator: Mr N Hamilton*

Designed to provide students with an understanding and practical knowledge of IT contracting, intellectual property laws relating to the IT industry and implementing contract design and negotiation strategies to achieve project objectives.

### 32806

#### Project A

6cp; *prerequisite: Graduate Diploma in Information Technology Management; corequisite: 21751 Management Research Methods*  
*subject coordinator: Dr J Feuerlicht*

See 32812 Project B below.

### 32812

#### Project B

6cp; *prerequisites: 32806 Project A; 21751 Management Research Methods*  
*subject coordinator: Mr D Wilson*

All students in the MBus in IT Management are required to enrol in and pass the project subjects. The project is normally undertaken in the final year of study. The project entails a substantial investigation, under the supervision of a member of the academic staff, and is examined on the quality of both a written report and an oral presentation of the project work. The oral presentation must be made in the final year of enrolment in the Master's course and must be presented at a satisfactory standard. Expert speakers may be available to present Master's seminars as required throughout the final year of the course. Students are required to attend the Master's seminars.

### 32901

#### Recent Advances in Computer Science

6cp

*subject coordinator: Dr S Prabhakar*

Review of key developments in computer science. Selection of topics from: software engineering, artificial intelligence, knowledge processing, computer graphics, theory of computer science, decision support systems, capacity planning, communications, distributed systems, and computer architecture.

### 32902

#### Recent Advances in Information Systems

6cp

*subject coordinator: Mr J Underwood*

Reviews some key developments in the information systems discipline. Some likely topics are: new techniques in database design, automated development methodologies, alternative system modelling techniques, system usability, quality in information

systems, organisation-wide network design, participative system design, managing the IT function in the next decade, security in information systems, evaluating the economics of information systems, and career paths in IT.

### 32912

#### Project

12cp

*subject coordinator: Professor J Debenham*

See 32924 Project below.

### 32924

#### Project

24cp

*subject coordinator: Professor J Debenham*

Nature of research: academic and professional. Research methodologies. Cost of research. Evaluation of research. Significance of research. Timeliness of research. Execution of a research project.

## SUBJECTS OFFERED BY OTHER FACULTIES

Students should consult the relevant faculty and its handbook for any late changes to subject information.

XXXXX

### Australian Studies I

6cp

*subject coordinator: tba*

This subject will introduce students to the language, history and culture of Australia. It will also introduce students to academic study in Australia.

XXXXX

### Multimedia Industry and Process

8cp

*subject coordinator: tba*

This unit examines the evolution of the multimedia industry, analysing it in terms of recent government policies, current and future job specifications, the multimedia production process, local and global markets for multimedia products and the costs associated with development.

It will provide a framework for the development of business plans, including project plans and budgets, and the resolution of issues of copyright and intellectual property.

XXXXX

### Multimedia Products and Technology

8cp

*subject coordinator: tba*

This unit examines the form and content of multimedia texts, including CD-ROMs, computer games and the Internet. It analyses these products in the broader context of conventional media products such as radio, television, film, publishing and the music industry, and draws on screen, textual and media studies to provide the theoretical framework. It will provide a comparative historical overview of the development of media forms and content, and the development of media audiences. It will place the development of multimedia technologies in the social context of the developing industries and audiences.

XXXXX

**Multimedia Project**

8cp

*subject coordinator: tba*

Students work in teams made of students specialising in complementary disciplines to develop a major project. For example, a team might comprise students majoring in computer science, design, education and project management. Topics such as projects management and business plan development are taught using a problem-based approach along side the project development as required.

015110

**Aboriginal Cultures and Philosophies**

8cp

This subject will introduce participants to Aboriginal culture and social organisation as expressions of Aboriginal cosmology. Contemporary Aboriginal culture will be presented as an evolving response to colonialism and as a reassertion of cultural empowerment.

21751

**Management Research Methods**

6cp; prerequisite: Graduate Certificate in Information Technology Management

*subject coordinator: Associate Professor B Ticehurst*

This subject will familiarise IT managers with a range of approaches used in management research, with an emphasis on approaches commonly used in practical settings. Advantages and limitations of different research approaches will be examined, as well as their applicability in different IT contexts. Experience will be provided in the design of research studies and in the analysis and interpretation of data and report presentation. Participants will acquire skills which will be useful in the conduct of research agendas in their own IT organisations, and in the critical evaluation of others research work.

21788

**Effective People Management**

6cp

*subject coordinator: Mr R Connor*

Deals with a range of management skills, competencies and understandings necessary for effective people management. It seeks to develop enhanced competence in managing others and, recognising the importance of

continuing personal learning and development in management, seeks to develop an increased sensitivity and understanding of self and others in organisational contexts.

21789

**Contemporary Management Practices**

6cp

*subject coordinator: Mr RW Connor*

This subject addresses a range of management practices appropriate to contemporary organisations. The unit provides students with an understanding of key aspects of current management practices, including: managerial relationships; intercultural management; leadership, status and power; negotiation; interviewing; team building; managerial audits; and managerial ethics.

21806

**Managing Organisational Change**

6cp

*subject coordinator: Dr K Sayer*

This subject examines the role of the manager in planning and facilitating change in an IT environment, as well as the managerial challenges to be faced. It explores and suggests organisational change interventions. Change issues relevant to IT such as technology assessment will receive special emphasis.

21807

**Total Quality and Productivity Management**

6cp; prerequisite: Graduate Certificate in Information Technology Management

*subject coordinator: Mr D Davis*

Productivity and quality are both key factors in successful performance in the IT industry. This subject aims to develop a clear understanding of the practical and managerial aspects of quality management and productivity management, including the fundamentals of TQM and its relationship to productivity. Students completing this subject will have a sound philosophical and practical basis for evaluating productivity and quality improvement programs and total quality implementation programs.

**21808****Strategic Business Management**

6cp; prerequisites: Graduate Certificate in Information Technology Management; 21806 Managing Organisational Change  
subject coordinator: Mr A Hermans

The nature of strategic issues; arenas of strategy; the information technology industry: context and issues; concepts of strategy; environmental analysis; capability analysis; development of strategic alternatives; evaluation and choice of strategic alternatives; stability, change and transformation; the process of strategy implementation; and strategic control and monitoring.

**22615****Accounting Information Systems**

6cp  
subject coordinator: Mr G Lowe

This subject presents a range of fundamental accounting principles. This subject is intended to provide basic skills in financial accounting and to apply this knowledge of accounting to evaluating computerised accounting systems. An accounting system is an example of an information system.

**24105****Marketing Principles**

4cp  
subject coordinator: Mr G Taberner

This subject aims to develop an awareness and understanding of marketing concepts and how these concepts apply to profit and non-profit organisations; to provide the foundations from which a more advanced study of marketing may be pursued; to show the relevance of the need for a marketing orientation in a dynamic and changing business environment; to allow students to test and apply marketing concepts in a dynamic simulated business environment; and to develop the skills necessary to formulate a basic marketing plan. The projects also highlight the need for group decision making for effective management.

**24704****Managing Client Relations**

6cp  
subject coordinator: Dr B Perrott

This subject reviews the nature of the business development process through focusing upon the specific needs of clients. It explores the complex issues of determining and focusing

on client needs as a key activity for IT managers who wish to maximise their impact. Specific IT-based case material will be used throughout the course to ensure that participants recognise the essential relationship between product and client satisfaction.

**45668****Teletraffic Engineering**

6cp  
subject coordinator: tba

Introduces the concepts associated with the design of common-usage telecommunication links and switching equipment. The subject will present busy hour engineering terms and service criteria for switching systems and techniques used to determine the trunk capacity. Trunk network configurations with numerous routing algorithms will also be examined.

**49031****Information Structures, Perception and User Interface Design**

6cp  
subject coordinator: tba

This subject will look at how authors will create information and how users will access it. It will introduce methodologies to structure the information to facilitate creation and access. Existing information classification and indexing schemes will be studied and extended to meet demands imposed by hypermedia systems. User interface design issues based on how we perceive and access information, and how different media can be used to effectively communicate a message, will also be studied in this subject.

**49201****Integrated Services Network**

6cp  
subject coordinator: tba

Switching methods, CCITT recommendations, SDH, ISDN technology, ISDN signalling, broadband ISDN, ATM standards, resource sharing and multiple access (ALOHA/CS/CD, CSMA/CD, Token Bus, Token Ring, QPSX, FFDI).

**49241****Hypermedia Technologies**

6cp  
subject coordinator: tba

This subject provides an introduction to hypermedia. It introduces basic components

and the structure of hypermedia systems, underlying technologies for capturing, compressing, structuring and authoring of different media (text, images, video and sound). Issues related to storage and transmission of large volumes of data are discussed, including temporal media synchronisation. The Internet and the World Wide Web are studied in detail.

## 49242

### **Mono Media Technologies**

6cp

*subject coordinator: tba*

This subject introduces engineering issues and state-of-the-art solutions related to capturing, representation, storage, compression and presenting digital media. Special emphasis is placed on images, video and audio. Topics such as colour space, image video and audio compression techniques and standards (JPEG, MPEG), processing of visual information for applications such as image and video databases will be studied.

## 49243

### **Design of Hypermedia Information Systems**

6cp

*subject coordinator: tba*

In this subject students will learn how to develop large complex hypermedia information systems that need to be maintained and updated over a period of time. Students will learn how to extract the structure of information and develop a document using SGML. Students will then develop programs to convert the marked-up documents into formats suitable for different browsers (such as HTML) and applications. The topics will also include life-cycle considerations project management in hypermedia systems development, and new technical issues such as copyright and social impact. In this subject industry standard application development tools will be used for practical work.

## 50457

### **Theories of the Visual**

8cp

*subject coordinator: tba*

The subject examines a number of different forms of visual representation (painting, photography, cinema, television, video) together with their different forms of theoretical critical description. The subject also

examines the broader theoretical debates within which these forms of visual representation have been placed e.g. visual representation and the representation of history; memory; nostalgia and the visual - from the photographic image through to such things as cinematic/televsual documentary; recent charged historical issues such as Vietnam, the Freedom Rides, AIDS and issues of representation, and recent material on pornography and gender. Not all of these media forms, theoretical perspectives or specific issues are covered each year.

## 51007

### **Media Studies**

4cp

*subject coordinator: tba*

The subject is a broad introduction to the study of popular media (TV, film, radio) through specific case studies and texts relating to them. In any one semester, Media Studies might address itself to genres such as sitcom, independent film, art and advertising, screen music or TV game shows. Class projects are based around specific media texts and events and can be offered in a variety of forms besides that of the essay.

## 52272

### **Sound, Music, Noise**

8cp

*subject coordinator: tba*

This subject is an introduction to the study of sound and music in a wide range of production forms and cultural contexts. The first part of the subject is structured as an overview in synoptic form and provides a framework for studying the distinct elements of sound, music and noise. In the principal context of art practice, a difference is established between modernist and post-modernist ideas of sound. A similar difference is marked between acoustic, analogue and digital/ sampling/ re-scripting approaches to the representation of sound. These ways of conceiving, producing and listening to sound are related to radio, music recording, film sound, media distribution systems, subjective senses of sound and to our experience of the urban and industrial environment. In a similar manner, various later aspects of the class coursework and assignments focus on the design implications of a sonorous sense of the world, whether this is expressed in an architectural vision, a broadcast production set of artefacts

and institutions, or in terms of a performance system.

## 52274

### Sound Studies

8cp

*subject coordinator: tba*

This subject examines the construction of voice in both poetic and technological terms, on its own and in relation to sound and music. It focuses primarily on voice and the spoken word in radio and performance, but also in other electronic media and technologies. It asks which voices are absent or silenced, and which are present in terms of social structures (sex, sexuality, gender, class, race, ethnicity and age). The effects of the structures of radio and professional values are discussed in relation to these absences and presences. There is a focus on the construction of voices and their 'authority' and 'inflection' through an examination of cultural, social and political speaking positions, rhetorics and genres.

## 54101

### Sound and Image

6cp

*subject coordinator: tba*

This subject introduces students to a range of written, visual and aural products and texts in the context of the study of, predominantly, Australian culture, so as to promote discussion of the strategies underlying them. The industrial and institutional bases for the production of such texts are linked to their consequences for individuals, communities, multi and sub-cultural groupings. The subject consists of lecture tutorial arrangements coupled with viewings of selected films, videos and sound works. Computer-based exercises integrate in-class teaching with students' own interests and capabilities and a major group based project is produced.

## 54110

### Media, Culture and Society

6cp

*subject coordinator: tba*

This subject introduces some of the major theoretical approaches to the study of media and culture and their relationship to society. It focuses on the historical development of the communication media and media theory, and of the relevant social theory. It explores different theoretical approaches to various aspects of media and cultural production

including institutional and industrial development, political economy, policy formulation and implementation, technological change, the convergence of telecommunications and broadcasting, professionalisation of the workforce and the construction of audiences.

## 54116

### Audiovisual Media Production

6cp

*subject coordinator: tba*

In this subject students will be introduced to the various image, sound and promotional industries of PR, advertising, radio, multimedia and sound. From a critical and theoretical viewpoint, students will examine historical, political, economic, cultural and technological links between these industries. Students will develop basic production skills which reflect the range of technologies, the cultural disciplines and the industrial contexts.

## 54150

### Computers and Print Production

4cp

*subject coordinator: tba*

This subject provides an intensive familiarisation subject for students interested in developing introductory skills relevant to other areas of the degree which utilise simple digital production technologies.

## 54151

### Computers and Audiovisual Production

4cp

*subject coordinator: tba*

This intensive subject provides students with an introduction to thinking about and using computers in audiovisual production. Intensive workshops are used to introduce computers and audiovisual production, overviewing digital production techniques used in a variety of industrial settings. Students develop simple projects in teams using basic software.

## 54153

### Video Basic

4cp

*subject coordinator: tba*

This subject provides a preliminary introduction to video production and to critical issues involved in the writing, design

and production of film, video and television programs. It is designed for students not enrolled in the Film, Video and Television major, as a means for them to gain basic understanding of issues involved in moving picture productions in the area of television journalism, documentary, drama feature and film/video advertising. Students will develop basic skills in shooting and editing video, and will work on a number of practical exercises designed to develop their skills in visual style, and an understanding of how film and video texts are constructed in terms of editing, camerawork and soundtrack.

### 54230

#### Aboriginal Social and Political History

8cp

Examines and analyses the impact of colonialism on indigenous peoples, with particular reference to the Aboriginal inhabitants of this region. The emergence of Aboriginal social and political movements will be presented as the basis for repossession of their traditional heritage in land and culture.

### 54231

#### Aboriginal People and the Media

8cp; prerequisites: 015110 *Aboriginal Cultures and Philosophies*; 54230 *Aboriginal Social and Political History*

Familiarises students with the field of debate in relation to the representation of Aborigines in the media, and with the productions of Aboriginal media organisations. Where possible, some written, video or film production could become part of the course assessment.

### 54294

#### Sound Design

8cp

subject coordinator: tba

This subject aims to introduce students conceptually and technically to production for audio design and broadcast sound. Recording, interviewing, listening, editing and mixing skills are taught in a way that stresses an understanding of how operational techniques work to produce meanings in radio. Students work in a stereo digital medium. Theoretical issues important for sound and audio design such as analogue and digital formats, listening, speaking positions, representation, professional values, and the relation between

culture, aesthetics and politics of sound are introduced at this level.

### 54299

#### NetDesign

8cp

subject coordinator: tba

This subject is offered to students wishing to learn how to plan, design and produce creative web sites and pages for a specific client/audience or purpose. The focus of the subject is on how the critical and practical composition of digital sounds and images are constructed for specific navigational configurations within interactive multimedia formats and cultural contexts. Emphasis is placed on developing critical and aesthetic strategies for the production of various audiovisual media resources for web sites across the communication, sound and image environment. The cultural and social implications of the production and consumption of various products and services via the Internet are addressed with a view to developing an understanding of how to best design new web sites for specific clients and audiences. Students design and produce a web site (web homepage with hyperlinks) and a number of in-class exercises covering the use of PageMill, GNN Press, Shockwave and HyperText Markup Language (HTML), creating tags and adding in-line sound and image documents.

### 54330

#### The Politics of Aboriginal History

8cp; prerequisites: *Aboriginal Studies subjects at 100 and 200 levels*

Introduces students to the wide range of historical work by Aboriginal and non-Aboriginal people over the last three decades, and encourages students to develop skills in the critical evaluation of this work in its political and social contexts. Students will enhance their knowledge of primary research materials for the field of Aboriginal history, and will develop their skills in the analysis and use of these sources.

### 54331

#### Aboriginal Forms of Discourse

8cp; prerequisites: 015110 *Aboriginal Cultures and Philosophies*; one *Aboriginal Studies subject at the 200 level*

Familiarises students with a broad range of Aboriginal forms of discourse – novels, plays, films, oral narratives – and introduces them to



methods of analysis, of both text and content, deriving from the disciplines of cultural studies and textual studies.

### 55902

#### Information Behaviour

6cp

*subject coordinator: tba*

The aim of this subject is to develop students' understanding of the information needs, motivations and behaviours of client groups. Students will identify, define and justify a client group for the purpose of providing information services and products and will develop an information profile of the group. They will also analyse and compare models of information seeking and utilisation, and will be introduced to the characteristics which influence or predict how people react to information and information products and services.

### 55903

#### Information Production and Presentation

6cp

*subject coordinator: tba*

In this subject students are introduced to theories, principles and skills relevant to the design, production, evaluation and dissemination of information products. Students will have the opportunity to work with a range of media types and formats, and to develop skills in restructuring and repackaging information to suit client needs.

### 55906

#### Organisation of Information

6cp

*subject coordinator: tba*

This subject examines and evaluates principles, theories and conceptual frameworks for the organisation of information and information resources for eventual retrieval in relation to a specific need. It deals with approaches to organisation and control based on intellectual content as well as those based on physical arrangement of information and information resources, against the background of a consideration of a variety of approaches to analysis.

### 55907

#### Information Retrieval

6cp

*subject coordinator: tba*

This subject examines the theory and practice of information retrieval. It deals with the principles on which information retrieval systems are based and the interaction between information retrieval systems and end-users. Approaches for the evaluation of information retrieval are identified and students are introduced to some information technologies commonly used by information professionals.

### 55910

#### User Documentation 1

6cp

*subject coordinator: tba*

This subject provides an opportunity for students to develop knowledge, skills and competencies in the translating of specialist materials for a non-specialist audience. It takes a client-oriented approach, combining information analysis techniques with writing techniques.

### 55911

#### User Documentation 2

6cp

*subject coordinator: tba*

In this subject students will manage a small user documentation project, producing material relevant to a targeted audience. They will also discuss some of the key issues in contemporary professional practice.

### 81021

#### Communication Technology

4cp

*subject coordinator: tba*

This subject provides an understanding of the current state of communication theory and practice with particular reference to the designer's role in shaping components of communication systems.

**81024****Computer Graphics I**

4cp

*subject coordinator: tba*

This subject provides the opportunity for selected postgraduate students to apply computer techniques to specific design projects using advanced graphics/animation programs.

**81030****3D Computer Animation 2**

4cp

*subject coordinator: tba*

This subject develops and expands the basic knowledge of both the theory and operation of computer animation as learnt in 81925 3D Computer Animation 1, refining the different types of computer graphics in animation. The course includes the creation and manipulation of 3D images. Topics covered include advanced computer animation systems and theory, various animation software applications and video production techniques.

**81923****Introduction to Design Computing**

4cp

*subject coordinator: tba*

This subject provides students with a working knowledge of the principles and applications of computer graphics to problem solving. The graphics techniques will include paintbrush systems, typography and spreadsheets. Projects provide an introduction to microcomputers, graphics and word-processing software packages.

**81925****3D Computer Animation I**

4cp

*subject coordinator: tba*

This subject equips students with the basic knowledge of both the theory and operation of computer animation and the different types of computer graphics. Topics covered include computer animation systems, animation software, animation production and dropping animation to videotape.

**82009****Human Factors and Design**

4cp

*subject coordinator: tba*

This subject provides an understanding of the current state of communication theory and practice with particular reference to the designer's role in shaping components of communication systems.

**82016****Graphic Visualisation**

4cp

*subject coordinator: tba*

This subject expands the awareness and ability of students with other disciplinary backgrounds to generate ideas and communicate visually through 'hands-on' experience.

**82017****2D and 3D Communication**

4cp

*subject coordinator: tba*

This subject introduces methods and conventions to explain design intentions through three-dimensional model forms and two-dimensional drafting techniques and processes.

**82915****Photography for Designers**

4cp

*subject coordinator: tba*

This subject introduces students to photography and its applications to enhance the communication of design projects.

**International Studies subjects**

Descriptions for subjects comprising the International Studies component of the combined Bachelor of Science in Computing Science/Bachelor of Arts in International Studies degree can be found in the School of Mathematical Sciences' 'Subject descriptions' section in this handbook.

# Numerical list of subjects

The following tables indicate the number and name of each subject, the semester or semesters in which it is offered, the credit-point value, and the prerequisites and corequisites (indicated by *c*). The letters A and S refer to the Autumn and Spring semesters respectively, and Y is used to indicate a year-long subject. All prerequisites are in terms of current undergraduate offerings. See the 'Subject descriptions' section for details of other possible prerequisites.

In the case of some elective subjects, no 'Semester offered' is shown. Elective offerings will vary according to demand.

## Bachelor of Science in Computing Science – core subjects

Subject number	Subject name	Semester offered	CP	Prerequisites
22615	Accounting Information Systems	A,S	6	Nil
31414	Information Systems	A,S	6	Nil
31415	Principles of Software Development A	A,S	6	31417 <i>c</i>
31416	Computer Systems Architecture	A	6	Nil
31417	Computing Practice	A,S	6	Nil
31424	Systems Modelling	A,S	6	Nil
31425	Principles of Software Development B	A,S	6	31415
31428	Quantitative Modelling	A,S	6	
31429	Procedural Programming	A,S	6	31415, 31425 <i>c</i>
31434	Database Design	A,S	6	31424
31436	Systems Software and Networks	A,S	8	31425, 31429, 31416
31444	Systems Design and Development	A,S	10	31434, 31436 <i>c</i>
31454	Project Management and the Professional	A	8	31444, 31697 or 31698
31455	Software Development Case Study	Y	10	31444, 31697 or 31698
31464	Information Technology Planning and Design	S	6	31428, 31436, 31444, 31436, 31697
31696	Industrial Training (F/T)	A	0	31414, 31415, 31416, 31417, 31424, 31429, 31434, 31436
31697	Industrial Training (F/T)	S	0	31696
31698	Industrial Training (P/T)	A,S	0	31414, 31415, 31416, 31417, 31424, 31429, 31434, 31436
31699	Industrial Training (P/T)	A,S	0	31698

**Note:** The subjects 31698 Industrial Training and 31699 Industrial Training must be taken for two semesters.

## Bachelor of Science in Computing Science (Honours) – core subjects

Subject number	Subject name	Semester offered	CP	Prerequisites
31945	Introduction to Computing Research		6	
31946	The Computing Literature		6	
31947	Honours Research Project		24	31945, 31946
31948	Honours Seminar 1		6	
31949	Honours Seminar 2		6	

**Bachelor of Information Technology – core subjects**

Subject number	Subject name	Semester offered	CP	Prerequisites
22615	Accounting Information Systems	A	6	Nil
24105	Marketing Principles	A	4	Nil
31414	Information Systems	A	6	Nil
31415	Principles of Software Development A	A	6	31718 <i>c</i>
31416	Computer Systems Architecture	A	6	Nil
31424	Systems Modelling	S	6	Nil
31434	Database Design	A	6	31729
31436	Systems Software and Networks	A	8	31416, 31729
31443	Distributed Databases and Client/Server Computing	S	6	31434
31444	Systems Design and Development	S	10	31434, 31436 <i>c</i>
31464	Information Technology Planning and Design	S	6	31756
31718	Contemporary Information Technology 1	A	6	Nil
31722	Commercial Programming	S	5	31414, 31415
31735	Information Systems and Organisation Development	A	4	Nil
31756	Project Management	A	5	31788
31764	Information Technology Strategy	S	4	Nil
31769	Contemporary Information Technology 2	S	4	31718
31770	Industry Project 1	S	5	Nil
31771	Business Requirements Analysis	S	5	31414
31779	Applications of Information Technology 1	S	5	31414
31781	Business Systems Design	A	5	31424
31789	Applications of Information Technology 2	A	5	31779
31790	Industry Project 2	A	5	31770

**Bachelor of Computing – core subjects**

Subject number	Subject name	Semester offered	CP	Prerequisites
xxxxx	Australian Studies 1	A,S	6	
22615	Accounting Information Systems	A,S	6	
31414	Information Systems	A,S	6	
31417	Computing Practice	A,S	6	
31424	Systems Modelling	A,S	6	
31425	Principles of Software Development B	A,S	6	31508
31428	Quantitative Modelling	A,S	6	31508
31429	Procedural Programming	A,S	6	31508
31434	Database Design	A,S	6	31424
31454	Project Management and the Professional	A,S	8	31511

Subject number	Subject name	Semester offered	CP	Prerequisites
31464	Information Technology Planning and Design	S	6	31454
31507	Australian Studies 2	A,S	6	Aust Studies 1
31508	Programming Fundamentals	A,S	6	
31509	Computer Fundamentals	A,S	6	
31510	Operating Systems	A,S	6	31509
31511	Systems Design	A,S	6	31424
31512	Networking 1	A,S	6	31429, 31509
31513	Networking 2	A or S	6	31512
31514	Computing Theory	A or S	6	31425
31931	Software Quality Assurance	A,S	6	31429

### Undergraduate electives

Subject number	Subject name	Semester offered	CP	Prerequisites
31140	Introduction to Computer Graphics	A	6	31425, 31429
31163	Knowledge Technology	A	6	31425 <i>or</i> 31429
31240	Topics in Computer Graphics	S	6	31140
31350	Project (2 semesters)	A,S	12	31444
31351	Project (1 semester)	A,S	12	31444
31352	Project	A,S	6	31444
31443	Distributed Databases and Client/Server Computing	S	6	31434
31513	Networking 2	A or S	6	31436
31735	Information Systems and Organisation Development	A	6	Nil
31737	Business Process Transformation	S	4	Nil
31743	Machine Learning	S	6	31428
31744	Case-based Reasoning	S	6	31163
31745	Knowledge-based Systems	A	6	31743 <i>or</i> 31744
31746	Artificial Intelligence Applications	A	6	31743 <i>or</i> 31744
31748	Programming on the Internet	A,S	6	31436
31749	Internet Commerce	A,S	6	31436
31764	Information Technology Strategy	S	4	Nil
31777	Human-Computer Interaction	A	6	31444
31778	Resources Management for IT Professionals	S	4	Nil
31860	Object-oriented Programming and C++	S	6	31424, 31429
31875	Parallel Programming	S	4	31429, 31436
31876	Operating Systems Facilities	A	6	31429, 31436
31894	Project	A,S	6	31444
31902	Auditing the Computer	S	4	22615
31904	Systems Programming	A	6	31429
31917	Commercial Programming	S	4	31429
31919	Distributed Software Programming	S	6	31436, 31920
31920	Network Management	S	6	31436

Subject number	Subject name	Semester offered	CP	Prerequisites
31921	Objectbases	*	4	31434
31922	Object-oriented Methodologies	A	6	31424
31924	Performance Modelling	A	6	31428, 31432, 31696-7, 31698-9
31925	Smalltalk	S	6	31415, 31424
31926	Paradigms of Intelligence	A	4	Nil
31927	Applications Development with Visual Basic	A	6	31414, 31415 or 31429, 31424 <i>c</i>
31928	Applications Development with Delphi	S	6	31414, 31415 or 31429, 31424 <i>c</i>
31931	Software Quality Assurance	S	6	31424
31950	Networked Enterprise Design	S	6	31424

### Aboriginal Studies subjects

Subject number	Subject name	Semester offered	CP	Prerequisites
015110	Aboriginal Cultures and Philosophies		8	Nil
54230	Aboriginal Social and Political History		8	Nil
54231	Aboriginal People and the Media		8	015110, 54230
54330	The Politics of Aboriginal History		8	See subject description
54331	Aboriginal Forms of Discourse		8	See subject description

Note: These subjects comprise the Aboriginal Studies sub-major; they may also be taken as electives.

### International Studies subjects

Subject number	Subject name	Semester offered	CP	Prerequisites
50140	Modernisation and Social Change	A, S	8	Nil
97x111	Chinese 1-10	A or S	8	See subject descriptions
97x121	Cantonese A1-A4, B1-B2	A or S	8	See subject descriptions
97x211	Japanese 1-6	A or S	8	See subject descriptions
97x311	Indonesian 1-6	A or S	8	See subject descriptions
97x320	Thai Language and Culture		8	See subject descriptions
97x331	Malaysian 1-6	A or S	8	See subject descriptions
97x414/5	French		8	See subject descriptions
97x424/5	German		8	See subject descriptions
97x434/5	Italian		8	See subject descriptions
97x501	Spanish 1-6	A or S	8	See subject descriptions
97x710	Greek		8	See subject descriptions
97x734	Russian		8	See subject descriptions
97x744	Croatian		8	See subject descriptions
97x754	Slovenian		8	See subject descriptions
97x764	Polish		8	See subject descriptions
97x774	Ukrainian		8	See subject descriptions
976101	Chinese East Asia	S	8	Nil
976111	Contemporary China	S	8	Nil
976211	Contemporary Japan	S	8	Nil

## 158 SCHOOL OF COMPUTING SCIENCES

Subject number	Subject name	Semester offered	CP	Prerequisites
976301	Contemporary South-East Asia	S	8	Nil
976401	Contemporary Europe	S	8	Nil
976501	Contemporary Latin America	S	8	Nil
977xxx	In-country Study 1		24	See subject descriptions
978xxx	In-country Study 2		24	See subject descriptions

**Note:** x indicates one of four levels of study. Details of all International Studies subjects can be found in the School of Mathematical Sciences' 'Subject descriptions' section in this handbook.

### Graduate Diploma in Information Technology – core subjects

Subject number	Subject name	Semester offered	CP	Prerequisites
31414	Information Systems	A,S	6	
31415	Principles of Software Development A	A,S	6	
31424	Systems Modelling	A,S	6	
31429	Procedural Programming	A,S	6	31508
31434	Database Design	A,S	6	31424
31508	Programming Fundamentals	A,S	6	
31509	Computer Fundamentals	A,S	6	
31512	Networking 1	A,S	6	31429, 31509

**Note:** Students may select any elective subjects for which they have the prerequisites, with the exception of Project, from the list of undergraduate electives.

### Master of Science in Computing

Subject number	Subject name	Semester offered	CP	Prerequisites
32106	Object-oriented Software Development	A99	6	Nil
32107	Formal Reasoning for Software Development	S99	6	Nil
32108	Specialist Topics in Artificial Intelligence	S98	6	Nil
32204	Advanced Data Management	A98	6	Nil
32205	Computer Communication Systems	S98	6	Nil
32206	Advanced Information Systems Modelling	S99	6	Nil
32207	Information Management	A99	6	Nil
32208	Information Processing Strategy	S99	6	32207
32306	Capacity Management	A98	6	Nil
32307	Operating Systems	S98	6	Nil
32308	Computer Architecture	S99	6	Nil
32402	Information Technology Environment	S98	6	Nil
32501	Computer Graphics	A	6	Nil
32502	Advanced Computer Graphics Techniques	S	6	32501

Subject number	Subject name	Semester offered	CP	Prerequisites
32503	Distributed Databases and Client/Server Computing	S	6	Nil
32504	Tool-based Systems Development		6	Nil
32508	Software Quality Management Systems	*	6	Nil
32509	Human-Computer Interaction in Information Systems	A	6	Nil
32510	Principles of Object-oriented Programming in C++	S	6	32106
32511	Principles of Object-oriented Programming in Smalltalk	S	6	32106
32512	Advanced Knowledge Technology	A	6	Nil
32513	Advanced Machine Learning	S	6	32512
32514	Advanced Case-based Reasoning	S	6	32512
32516	Internet Programming	A,S	6	Nil
32517	Commerce on the Internet	A,S	6	Nil
32526	Designing the Networked Enterprise	A,S	6	Nil
32901	Recent Advances in Computer Science	A98, A99	6	Nil
32902	Recent Advances in Information Systems	A98, A99	6	Nil
32912	Project		12	By arrangement
32924	Project	Y	24	By arrangement

**Master of Business in Information Technology Management**

Subject number	Subject name	Semester offered	CP	Prerequisites
21751	Management Research Methods	A	6	GradCertInfTechM
21788	Effective People Management	A	6	Nil
21789	Contemporary Management Practices	S	6	Nil
21806	Managing Organisational Change	A	6	Nil
21807	Total Quality and Productivity Management	A	6	GradCertInfTechM
21808	Strategic Business Management	S	6	GradCertInfTechM, 21806
24704	Managing Client Relations	S	6	Nil
32601	Advanced Project Management	A	6	Nil
32602	Impact of Information Technology	Summer	6	Nil
32603	Software Quality Management	S	6	Nil
32604	Systems Integration	S	6	32601
32605	Managerial Analysis and Evaluation of Information Systems	S	6	Nil
32701	Advances in Information Technology	S	6	Nil
32702	Contemporary Telecommunications	S	6	Nil
32703	Information Technology Strategy	S	6	Nil
32704	Strategic IT Contract Management	S	6	GradCertInfTechM
32806	Project A	A,S	6	GradDipInfTechM, 21751c
32812	Project B	A,S	12	32806



**Master of Interactive Multimedia**

Subject number	Subject name	Semester offered	CP	Prerequisites
xxxxx	Multimedia Industry and Process		8	
xxxxx	Multimedia Products and Technology		8	
xxxxx	Multimedia Project		24	Grad Dip in Multimedia
xxxxx	Text-Based Systems		6	
31429	Procedural Programming	A,S	6	
31436	Systems Software and Networks	A,S	8	31429
31512	Networking 1	A,S	6	
31513	Networking 2		6	31512
31862	Fundamentals of Human – Computer Interaction	A	6	
31863	Human–Computer Interaction Tools and Techniques	S	6	
31864	Implementation of Human–Computer Interaction	S	6	
31876	Operating Systems Facilities	A	6	
31904	Systems Programming	A	6	
31927	Applications Development with Visual Basic	A,S	6	
32106	Object-oriented Software Development	A	6	
32307	Operating Systems	S	6	
32501	Computer Graphics	A	6	
32502	Advanced Computer Graphics Techniques	S	6	
32509	Human–Computer Interaction in Information Systems	A	6	
32516	Internet Programming	A,S	6	
32522	C for Systems Programmers	S	6	
49031	Information Structures, Perception and User Interface Design		6	
49241	Hypermedia Technologies		6	
49242	Mono Media Technologies		6	
49243	Design of Hypermedia Information Systems		6	
50457	Theories of the Visual		8	
51007	Media Studies		4	
52272	Sound, Music, Noise		8	
52274	Sound Studies		8	
54116	Audiovisual Media Production		6	
54150	Computers and Print Production		4	
54151	Computers and Audiovisual Production		4	
54294	Sound Design		8	
54299	NetDesign		8	
54101	Sound and Image		6	
54110	Media, Culture and Society		6	
54153	Video Basic		4	
55902	Information Behaviour		6	

Subject number	Subject name	Semester offered	CP	Prerequisites
55906	Organisation of Information		6	
55907	Information Retrieval		6	
55903	Information Production and Presentation		6	
55910	User Documentation 1		6	
55911	User Documentation 2		6	
81021	Communication Technology		4	
81925	3D Computer Animation 1		4	
81024	Computer Graphics 1		4	
81030	3D Computer Animation 2		4	
81923	Introduction to Design Computing		4	
82009	Human Factors and Design		4	
82016	Graphic Visualisation		4	
82017	2D and 3D Communication		4	
82915	Photography for Designers		4	

**Master of Science in Internetworking**

Subject number	Subject name	Semester offered	CP	Prerequisites
31920	Network Management	S	6	
31940	Systems Programming	A	6	
32510	Principles of Object-oriented Programming in C++	S	6	
32516	Internet Programming	A,S	6	
32518	Internetworking Research	A	6	GradDip in Internetworking
32519	Internetworking Project	A,S	18	GradDip in Internetworking
32520	UNIX Systems Administration	A	6	
32521	Internetworking	A	6	32524
32522	C for Systems Programmers	A	6	
32523	Operating Systems for Internetworking	A	6	
32524	LANs and Routing	S	6	
32525	Distributed Software Programming	S	6	
32527	Internetwork Design	S	6	32527
45668	Teletraffic Engineering	S	6	
49201	Integrated Services Network	A	6	

# Alphabetical list of subjects

## Undergraduate subjects

### Explanatory notes

- <sup>1</sup> Subjects taught by other faculties
- <sup>2</sup> BInfTech only
- <sup>3</sup> GradDipInfTech and Graduate Certificates only
- <sup>4</sup> Elective subject
- <sup>5</sup> Not offered in 1998
- <sup>6</sup> Honours only
- <sup>7</sup> BSc only
- <sup>8</sup> BComp only
- <sup>9</sup> BSc BA subject
- <sup>10</sup> Not for BSc or BInfTech

Aboriginal Cultures and Philosophies <sup>1,4</sup>	015110	Distributed Databases and Client/ Server Computing <sup>2,4</sup>	31443
Aboriginal Forms of Discourse <sup>1,4</sup>	54331	Distributed Software Programming <sup>4</sup>	31919
Aboriginal People and the Media <sup>1,4</sup>	54231	French 1–4 <sup>1,9</sup>	97x414/5
Aboriginal Social and Political History <sup>1,4</sup>	54230	German 1–4 <sup>1,9</sup>	97x424/5
Accounting Information Systems <sup>1</sup>	22615	Greek 1–4 <sup>1,9</sup>	97x710
Applications Development with Delphi <sup>4</sup>	31928	Honours Research Project <sup>5,6</sup>	31947
Applications Development with Visual Basic <sup>4</sup>	31927	Honours Seminar 1 <sup>5,6</sup>	31948
Applications of Information Technology 1 <sup>2</sup>	31779	Honours Seminar 2 <sup>5,6</sup>	31949
Applications of Information Technology 2 <sup>2</sup>	31789	Human–Computer Interaction <sup>4</sup>	31777
Artificial Intelligence Applications <sup>4</sup>	31746	In-country Study 1 <sup>9</sup>	977xxx
Auditing the Computer <sup>4</sup>	31902	In-country Study 2 <sup>9</sup>	978xxx
Australian Studies 1 <sup>1,10</sup>	xxxxx	Indonesian Language and Culture 1–4 <sup>1,9</sup>	97x311
Australian Studies 2 <sup>10</sup>	31507	Industrial Training (F/T) <sup>7</sup>	31696
Business Process Transformation <sup>4</sup>	31737	Industrial Training (F/T) <sup>7</sup>	31697
Business Requirements Analysis <sup>2</sup>	31771	Industrial Training (P/T) <sup>7</sup>	31698
Business Systems Design <sup>2</sup>	31781	Industrial Training (P/T) <sup>7</sup>	31699
Cantonese Language and Culture 1–4 <sup>1,9</sup>	97x121	Industry Project 1 <sup>2</sup>	31770
Case-based Reasoning <sup>4</sup>	31744	Industry Project 2 <sup>2</sup>	31790
Chinese Language and Culture 1–4 <sup>1,9</sup>	97x111	Information Systems	31414
Chinese East Asia <sup>1,9</sup>	976101	Information Systems and Organisation Development	31735
Commercial Programming <sup>2</sup>	31722	Information Technology Planning and Design <sup>2,7,8</sup>	31464
Commercial Programming <sup>4</sup>	31917	Information Technology Strategy <sup>4</sup>	31764
Computer Systems Architecture <sup>2,7</sup>	31416	Internet Commerce <sup>4</sup>	31749
Computer Fundamentals <sup>10</sup>	31509	Introduction to Computer Graphics <sup>4</sup>	31140
Computing Literature, The <sup>5,6</sup>	31946	Introduction to Computing Research <sup>5,6</sup>	31945
Computing Practice	31417	Japanese Language and Culture 1–4 <sup>1,9</sup>	97x211
Computing Theory <sup>8</sup>	31514	Knowledge Technology <sup>4</sup>	31163
Contemporary China <sup>1,9</sup>	976111	Knowledge-based Systems <sup>4</sup>	31745
Contemporary Information Technology 1 <sup>2</sup>	31718	Languages and Translators <sup>4</sup>	31654
Contemporary Information Technology 2 <sup>2</sup>	31769	Machine Learning <sup>4</sup>	31743
Contemporary Japan <sup>1,9</sup>	976211	Malaysian Language and Culture 1–4 <sup>1,9</sup>	97x331
Contemporary Latin America <sup>1,9</sup>	976501	Marketing Principles <sup>1,2</sup>	24105
Contemporary South-East Asia <sup>1,9</sup>	976101	Modernisation and Social Change <sup>9</sup>	50140
Contemporary Europe <sup>1,9</sup>	976401	Networking 1 <sup>10</sup>	31512
Croatian 1–4 <sup>1,9</sup>	97x744	Networking 2 <sup>4</sup>	31513
Database Design	31434	Network Management <sup>4</sup>	31920
		Networked Enterprise Design <sup>4</sup>	31950
		Objectbases <sup>4,5</sup>	31921
		Object-oriented Methodologies <sup>4</sup>	31922
		Object-oriented Programming and C++ <sup>4</sup>	31860
		Operating Systems <sup>10</sup>	31510
		Operating Systems Facilities <sup>4</sup>	31876
		Paradigms of Intelligence <sup>4</sup>	31926
		Parallel Programming <sup>4</sup>	31875
		Performance Modelling <sup>4</sup>	31924
		Polish 1–4 <sup>9</sup>	97x764
		Politics of Aboriginal History, The <sup>1,4</sup>	54330
		Principles of Software Development A <sup>2,7</sup>	31415
		Principles of Software Development B	31425
		Procedural Programming	31429
		Programming Fundamentals <sup>10</sup>	31508

Programming on the Internet <sup>4</sup>	31748
Project (1 semester) 12cp <sup>4</sup>	31351
Project (2 semesters) 12cp <sup>4</sup>	31350
Project <sup>4</sup>	31352
Project <sup>4</sup>	31894
Project Management <sup>2</sup>	31756
Project Management and the Professional	31454
Quantitative Modelling	31428
Resources Management for IT Professionals <sup>4</sup>	31778
Russian 1–4 <sup>1,9</sup>	97x734
Slovenian 1–4 <sup>1,9</sup>	97x754
Smalltalk <sup>4</sup>	31925
Software Development Case Study <sup>7</sup>	31455
Software Quality Assurance <sup>4</sup>	31931
Spanish Language and Culture 1–4 <sup>9</sup>	97x501
Systems Design <sup>10</sup>	31511
Systems Design and Development <sup>2,7</sup>	31444
Systems Modelling	31424
Systems Programming <sup>4</sup>	31904
Systems Software and Networks <sup>2,7</sup>	31436
Thai 1–4 <sup>1,9</sup>	97x320
Topics in Computer Graphics <sup>4</sup>	31240
Ukrainian 1–4 <sup>1,9</sup>	97x774

## Postgraduate subjects

Advanced Case-based Reasoning	32514
Advanced Computer Graphics Techniques	32502
Advanced Data Management	32204
Advanced Information Systems Modelling	32206
Advanced Knowledge Technology	32512
Advanced Machine Learning	32513
Advanced Project Management	32601
Advances in Information Technology	32701
Audiovisual Media Production	54116
C for System Programmers	32522
Capacity Management	32306
Commerce on the Internet	32517
Communication Technology	81021
Computer Architecture	32308
Computer Communication Systems	32205
Computer Graphics	32501
Computer Graphics 1	81024
Computers and Audiovisual Production	54151
Computers and Print Production	54150
Contemporary Management Practices	21789
Contemporary Telecommunications	32702
Design of Hypermedia Information Systems	49243
Designing the Networked Enterprise	32526
Distributed Databases and Client/Server Computing	32503
Distributed Software Programming	32525
Effective People Management	21788
Formal Reasoning for Software Development	32107
Fundamentals of Human-Computer Interaction	31862
Graphic Visualisation	82016
Human-Computer Interaction in Information Systems	32509
Human-Computer Interaction Tools and Techniques	31863
Human Factors and Design	82009
Hypermedia Technologies	49241
Impact of Information Technology	32602
Implementation of Human-Computer Interaction	31864
Information Behaviour	55902
Information Management	32207
Information Processing Strategy	32208
Information Production and Presentation	55903
Information Retrieval	55907
Information Structures, Perception and User Interface Design	49031
Information Technology Environment	32402
Information Technology Strategy	32703
Integrated Services Network	49201
Internetwork Design	32527
Internet Programming	32516
Internetworking	32521
Internetworking Project	32519
Internetworking Research	32518
Introduction to Design Computing	81923

LANs and Routing	32524	Project A	32806
Management Research Methods	21751	Project B	32812
Managerial Analysis and Evaluation of Information Systems	32605	Recent Advances in Computer Science	32901
Managing Client Relations	24704	Recent Advances in Information Systems	32902
Managing Organisational Change	21806	Software Quality Management	32603
Media, Culture and Society	54110	Software Quality Management Systems	32508
Media Studies	51007	Sound and Image	54101
Mono Media Technologies	49242	Sound Design	54295
Multimedia Industry and Process	xxxxx	Sound, Music, Noise	52272
Multimedia Products and Technology	xxxxx	Sound Studies	52274
Multimedia Project	xxxxx	Specialist Topics in Artificial Intelligence	32108
NetDesign	54299	Strategic Business Management	21808
Network Management	32xxx	Strategic IT Contract Management	32704
Object-oriented Software Development	32106	Systems Integration	32604
Operating Systems	32307	Teletraffic Engineering	45668
Operating Systems for Internetworking	32523	Text-Based Systems	xxxxx
Organisation of Information	55906	Theories of the Visual	50457
Photography for Designers	82915	3D Computer Animation 1	81925
Principles of Object-oriented Programming in C++	32510	3D Computer Animation 2	81030
Principles of Object-oriented Programming in Smalltalk	32511	Tool-based Systems Development	32504
Project	32912	Total Quality and Productivity Management	21807
Project	32924	UNIX Systems Administration	32520
		User Documentation 1	55910
		User Documentation 2	55911
		Video Basic	54153
		2D and 3D Communication	82017

# Boards and committees

---

## FACULTY BOARD IN MATHEMATICAL AND COMPUTING SCIENCES

### Ex officio members

*Dean of Faculty*

Professor M Fry (Chair)

*Head, School of Mathematical Sciences*

Associate Professor G J McLelland (Deputy Chair)

*Head, School of Computing Sciences*

Associate Professor J J Edwards

*The Professoriate*

Professor J K Debenham, School of Computing Sciences

Professor L Hravey, School of Computing Sciences

Professor I T Hawryszkiewicz, School of Computing Sciences

Professor J M Hughes, School of Computing Sciences

Professor E Platen, School of Mathematical Sciences

Professor B S Thornton, School of Mathematical Sciences

*Faculty Administrator*

Vacant

### Nominated members

Associate Professor E Hazel, Centre for Learning and Teaching

Dr D Green, Faculty of Science

Ms E Cupper, University Library

Dr A Mack, Faculty of Engineering

Professor A Hall, Faculty of Business

### Elected staff members

#### School of Mathematical Sciences

*Academic staff*

Associate Professor G L Cohen

Ms L Green

Mr T M Langtry

Dr G H Smith

Associate Professor D J Street

Ms L N Wood

Mr P Wright

#### School of Computing Sciences

*Academic staff*

Mr P Bebbington

Mr J Colville

Associate Professor T Hintz

Dr B Howarth

Dr C B Jay

Mr C S Johnson

Mr U Szewcow

### Faculty of Mathematical and Computing Sciences

*Support staff*

Ms I Chu

Ms L G McCoy

### Elected student members

#### School of Mathematical Sciences

Mr D Goh

Mr J Moon

#### School of Computing Sciences

Ms C Choy

Vacant

### Official observers

Mr H Bruce, Faculty of Humanities and Social Sciences

Mr A Mowbray, Faculty of Law

## FACULTY GRADUATE STUDIES COMMITTEE

### Ex officio members

*Dean of the Faculty*

Professor M Fry

*Head, School of Mathematical Sciences*

Associate Professor G J McLelland

*Head, School of Computing Sciences*

Associate Professor J J Edwards

*Director, Postgraduate Studies, School of Mathematical Sciences*

Associate Professor G L Cohen

*Director, Postgraduate Studies, School of Computing Sciences*

Professor J K Debenham

*Faculty Administrator*

Vacant

### Nominated members

*School of Mathematical Sciences*

Dr Y Zinder

*School of Computing Sciences*

Dr K G Suffern

## SCHOOL ADVISORY COMMITTEES

### School of Mathematical Sciences

#### Ex officio members

*Dean of Faculty*

Professor M Fry

*Head, School of Mathematical Sciences*

Associate Professor G J McLelland

#### Academic staff member

Associate Professor G L Cohen

#### External members

Dr N Barton, Manager, Applied and Industrial Mathematics Program, Division of Mathematics and Statistics, CSIRO

Dr J Green (Chair), Executive Director, Quantitative Applications Division, Macquarie Bank

Dr G Lack, Director, Management Consultancy Division, Coopers & Lybrand Consultants

Dr R McPhedran, University of Sydney

Mr R Morath, Chief Executive, MLC Investments

Mr P Newnam, Computer Systems Specialist, Surveillance Division, Australian Stock Exchange

#### Recent graduates

Mrs D Nash, Commonwealth Bank of Australia

Mr L Rask, CS First Boston Australia

Mr N Rugg, Australian Stock Exchange

### School of Computing Sciences

#### Ex officio members

*Dean of Faculty*

Professor M Fry

*Head, School of Computing Sciences*

Associate Professor J J Edwards

#### Academic staff members

Professor J K Debenham

Dr B Howarth

#### External members

Ms M Alexander (Chair), Expertise Australia Pty Ltd

Mr C Connaughton, Principal Consultant, Computer Sciences Corporation Australia Pty Ltd

Mr J Goddard, Honorary Associate, School of Computing Sciences

Mr P Steele, Senior Consultant, Totalizator Agency Board of NSW

Vacant

Vacant

Vacant

#### Recent graduates

Ms L Francis, Maxim Technology Ltd

Vacant

## COURSE ADVISORY COMMITTEES

### Bachelor of Mathematics and Finance – Course Advisory Committee

#### Ex officio members

*Head, School of Finance and Economics*

Professor C Chiarella (Chair)

*Head, School of Mathematical Sciences*

Associate Professor G J McLelland

#### Academic staff members

Associate Professor G L Cohen, Deputy

Head, School Mathematical Sciences

Dr M Stevenson, Senior Lecturer, School of Finance and Economics

#### External members

Dr L Balzer, Lend Lease Investment Management

Dr J Gray, AMP Investment

Dr J Green, Executive Director, Quantitative Applications Division, Macquarie Bank

Associate Professor R Trevor, Australian

Graduate School of Management, University of New South Wales

Dr P Vann, Partner, Condell, Vann and Co

### Bachelor of Information Technology – Course Steering Committee

*Dean of Faculty*

Professor M Fry

*Head, School of Computing Sciences*

Associate Professor J J Edwards

*Director, Undergraduate Studies*

Dr B Howarth

*BlInfTech Coordinator*

Mr J Underwood

*Director, Industry Liaison*

Ms A Watkins

**Exernal members**

Mr G Andean, Manager—Technical Systems, Information Services, Nestlé Australia Ltd

Ms C Andrews, Manager, Resources Planning, Technology Department, Westpac Banking Corporation

Mr H Babbington, Staffing Programs Manager, Pacific Power

Mr F Balboni, Partner, Price Waterhouse Urwick

Ms J Busby, Controller, IT Systems Development, Australian Broadcasting Corporation

Mr K Crowe, Systems Development Manager, Westpac Banking Corporation

Ms A Diab, Manager Graduate Recruitment, Andersen Consulting

Mr G Emanuel, Human Resources

Consultant, Optus Communications

Mr P Fuller, Manager Information Support Services, St.George Bank Ltd

Mr E Furlong, Architecture Manager, IBM Global Services Australia Ltd

Ms F Galliot, Graduate Recruitment Coordinator, Bankers Trust Australia Limited

Mr T Gruzin, Partner, Andersen Consulting

Ms D Haines, Graduate Recruitment

Manager, Price Waterhouse Urwick

Mr R Harris, Human Resources Consultant, EDS

Ms S Hayes, Application Developer Associate, Macquarie Bank Ltd

Mr M Hogan, Senior Manager, Applications Systems and Technology Department, Reserve Bank of Australia

Ms J James, Manager Resources—APC, IBM Global Services Australia Ltd

Mr Stephen Lau, Technical Development Leader, American Express International Inc

Mr J Loebenstein, Chief General Manager—Information Technology, St.George Bank Ltd

Mr A Luxford, Human Resources Officer, CSC Australia

Ms D Maddigan, Manager, Recruitment, Oracle Systems

Mr P Manalo, Manager IS Technology Research, Nestlé Australia Ltd

Ms S Mostacci, Application Developer Executive, Macquarie Bank Ltd

Ms J Mowatt, National Training and Development Manager, Woolworths Supermarkets

Mr T Mulligan, General Manager, Information Services, Legal and General Life of Australia Ltd

Mr J Niven, MIS Manager, Otis Elevator Company Pty Ltd

Ms V Norris, IT Account Manager, Ampol Petroleum

Ms M Richardson, Customer Relationship Manager, NRMA Information Services Pty Ltd

Mr W Rogers, Program Manager Education, IBM Global Service Australia Ltd

Ms Sylvie Sheehan, Human Resources Manager, Amdahl Pacific Services, Pty Ltd

Mr J Short, Manager, Human Resources, Qantas Information Technology Ltd

Mr Kevin Smart, Manager, IT Recruitment, Macquarie Bank Ltd

Mr D Steinbeck, Human Resources Manager, CISCO Systems Australia

Mr N Stewart, Partner, Price Waterhouse Urwick

Ms J-A Tooth, Human Resources and Development Manager, Pacific Power

Mr Michael Walsh, Human Resources and Quality Consultant, Seimens Nixdorf Information Systems Pty Ltd

Mr R Watson, IT Architect, IBM Global Services Australia Ltd

Mr B Weir, Acting Director of Technology, NSW Department of School Education

Mr G Willson, Head of Systems and Technology Department, Reserve Bank of Australia

Mr C Zyner, Personnel Manager (IS), Colonial

**Student representatives**

Ms L Chai

Ms A Navarro

**UTS mentors**

This group consists of a number of academic staff from the School of Computing Sciences.

Their principal role is to ensure that students will benefit from the industry placement.

The mentors act as the primary point of contact between the student and the University, and between the sponsor and the University during the industry placement.



# Staff list

---

## *Professor and Dean of Mathematical and Computing Sciences*

M Fry, MA (Cantab), MSc (Lond), PhD (Syd), DIC

## *Executive Assistant*

L M Gustowski

## *Technical Support Manager*

P D Gale, BScEng (Aero) (UNSW), MAHS, FWCAE

## *Faculty Administrator*

Vacant

## *Executive Officer*

G C Goodwin-Moore, BSc (Hons) (Lond)

## *Student Administration Manager*

L G McCoy, BA (UNE)

## *Industry Liaison Officer*

D A Saunders

## *Professional Programs Manager*

A Stevens, BA, MAppPsych (Macq)

## *Graduate Administration Officer*

L Abraham, BA (W'gong)

## *Student Liaison Officers*

I Chu

J C Smith

## *Liaison Officer*

Vacant

## **School of Mathematical Sciences**

### *Associate Professor and Head of School*

G J McLelland, BSc, PhD (Syd)

### *Associate Professor, Deputy Head of School and Director, Postgraduate Studies*

G L Cohen, MSc (Syd), PhD (UNSW), CMath, FIMA, FAustMS

### *Director, Undergraduate Studies*

G H Smith, MSc (Rand), PhD (UNSW), DipGeoscience (Macq)

### *Adjunct Professor*

R C McPhedran, BSc (Hons), PhD (Tas), FAIP, FOSA

### *Honorary Associates*

K T Atanassov, BSc (Sofia), PhD (BAS)

L Cooks, MSc, PhD (Lvov)

K R McCloy, BSurv (UNSW), PhD (Adel)

R S Melham, BSc, DipEd (UNSW), MLitt (UNE), MA (Syd), PhD (UTS)

N A Nicorovici, DipPhys, PhD (Bucharest), MOSA

## *Faculty Reader in Applied Mathematics*

L C Botten, BSc (Hons), PhD (Tas), FAIP, FAustMS, MACS, MOSA

## **Computational Mathematics Unit**

### *Senior Lecturer and Head of Unit*

T M Park, BSc (Manc), MSc (UNSW), FACS, MIEEE, MBCS

### *Professor*

B S Thornton, FTS, PhD (UNSW), DSc (Syd), CPhys, CEng, FInstP, FBCS, FACS, FRAeS, FIEAust

### *Associate Professor*

L C Botten, BSc (Hons), PhD (Tas), FAIP, FAustMS, MACS, MOSA

### *Senior Lecturers*

T N Langtry, BA (Hons) (UNSW), MAppSc (NSWIT), PhD (UNSW), MACS

K W Ozanne, BA (Hons) (Melb), MSc (Lond)

### *Lecturers*

D R Porteus, BSc, DipEd (Tas), MACE

R M Sorli, BSc (Hons) (Syd), MAppSc (NSWIT), MACS

## **Mathematics Unit**

### *Associate Professor and Head of Unit*

G L Cohen, MSc (Syd), PhD (UNSW), CMath, FIMA, FAustMS

### *Professor of Quantitative Finance*

E Platen, MSc, PhD (Dresden), DrScNat (Berlin)

### *Associate Professor*

G J McLelland, BSc, PhD (Syd)

### *Senior Lecturers*

B J Moore, MSc (Syd), PhD (Cantab)

G H Smith, MSc (Rand), PhD (UNSW), DipGeoscience (Macq)

L N Wood, BSc (Hons) (UNSW), DipEd (Tech) (SCAE), MA (Macq)

### *Lecturers*

M Coupland, BSc, DipEd, MEd (Syd)

I D Hoffman, BSc (Hons), PhD (UNSW)

B W Stephenson, BAppSc (NSWIT), DipTeach (Syd Teach Coll), MA (UNSW)

## Statistics and Operations Research Unit

*Associate Professor and Head of Unit*

D J Street, BSc (Hons) (Q'ld), PhD (Syd), FTICA

*Senior Lecturers*

P Petocz, BA (Hons), PhD (UNSW), DipEd (Tech) (SCAE)

Y Zinder, MSc (Gorky), PhD (AcadSc, USSR), MASOR

*Lecturers*

L Groen, BSc, DipEd (Syd), GradDipOR (NSWIT), MAppSc (UTS), MCom (Hons) (UNSW), MASOR

J M Hogg, BSc (Syd), MSc (OR) (UNSW), MASOR

E Lidums, BSc (Hons), MSc (Syd)

R I Rozsasi, BSc (Syd), AFIMA

P A Wright, BA (Macq), MStats, MEngSc (UNSW)

## Administrative and technical staff

*Executive Assistant*

Vacant

*Systems Administrator (Fixed Term)*

G J Lingard, BSc (Hons) (UNE)

*Computer Systems Support Officer*

E B Lindsay

## Research staff

*Postdoctoral Research Fellows*

W T Hung, BAppSc (NSWIT), MEngSc (UNSW), PhD (Macq), MASOR, AFIMA

R S Melham, BSc, DipEd (UNSW), MLitt (UNE), MA (Syd), PhD (UTS)

## University Statistical Consulting Service

*Associate Professor and Director*

D J Street, BSc (Hons) (Q'ld), PhD (Syd), FTICA

*Assistant Statistical Consultant*

J S Allen, BSc (Hons) (Staffs), MSc (Reading)

## Mathematics Study Centre

*Senior Lecturer and Director*

L N Wood, BSc (Hons) (UNSW), DipEd (Tech) (SCAE), MA (Macq)

*Lecturers*

J Harnett, BA (Hons) (Macq), DipTeach (Tas), PhD (Syd)

N F Smith, BEc (Hons) (Syd)

*Associate Lecturers*

P F Coutis, BSc (Hons) (UNSW)

J H Hayne, BA, DipEd, MSc (Macq)

## School of Computing Sciences

*Associate Professor and Head of School*

J J Edwards, BSc (Hons), MSc, PhD (Syd), MACS, MASOR

*Professor of Computing Science, Deputy Head of School and Director, Postgraduate Studies*

J K Debenham, MA, MSc (Dub), PhD (Syd)

*Professor of Information Systems*

L Harvey, BSc (Hons), PhD (Lanc), MACS

*Professor of Computing Science*

I T Hawryskiewicz, BE (Hons), ME (Adel), PhD (MIT), MACS

*Professor of Computing*

J M Hughes, BSc (Syd), MIEEEE, FACS, MBCS

*Adjunct Professor*

L Constantine, SB (MIT)

*Director, Undergraduate Studies*

B Howarth, BSc (UNSW), MEng (N'cle), PhD (Calif), SMIEEEE, MACS

*Honorary Associates*

J Goddard, DipTech (Public Admin) (NSWIT), MSCS, FACS

D Herbison-Evans, BA (Hons), MA, DPhil (Oxon), Dip (Dance Ed) (Sydney Dance Development Centre)

W Holmes, BEE (Melb)

*Faculty Reader in Computing Science*

C B Jay, BSc (Hons) (Syd), PhD (McG)

## Computing Methods

*Senior Lecturers*

C B Jay, BSc (Hons) (Syd), PhD (McG)

T Osborn, BMath (Hons), MMath, PhD (N'cle), INNS, ACM

R Rist, BSc (Psych) (Hons), BSc (ComSc) (UNSW), GradDip (CCA), MSc, MPhil, PhD (Yale), MACS

K G Suffern, BSc (Hons), MSc (Monash), MSc (Corn), PhD (Syd), MACS

*Lecturers*

B R E Lederer, BSc (Hons), MEngSc (UNSW), PhD (Syd), MACS

S Prabhakar, BE, PhD (IISc)

R van der Meyden, MA (Syd), PhD (Rutgers)

## Computer Systems

*Associate Professor*

T B Hintz, BSc (EE) (Texas), MSc (EE), DSc (EE) (N Mexico State), MACS, MACM, MIEEEE

*Senior Lecturers*

B Howarth, BSc (UNSW), MEng (N'cle), PhD (Calif), SMIEEEE, MACS

U Szewcow, BSc, DipNAAC (Syd), MEngSc (UNSW), MIEEEE, MACS

*Lecturers*

J Colville, MSc (Melb), MBCS, MACS, CEng  
 S K Jha, MEng (Lvov), Grad IEAust, MIEE  
 C W Johnson, MAppSc (NSWIT), MComp  
 (Macq), MRACI, CChem, MACS  
 H V Tu, BSc, BE (Montreal), ME (Hons)  
 (W'gong), MCSEE, MACS

**Information Systems Management**

*Senior Lecturers*

J J Hammond, BA, DipTchg (NZ), MScSoc  
 (UNSW), FACS, MBCS, MACE  
 D N Wilson, BSc (Hons), MSc (UTS), CEng,  
 MBCS, MACS, MACM, MQSA

*Lecturers*

R P Bebbington, BSc (Tech), MEngSc, MCom  
 (UNSW), MACS  
 J Clark, BEcon (JCU), MEcon (NMexico),  
 IASTED, ACM, BIM  
 N Hamilton, BInfTech, MInfmSys (Q'ld),  
 Barrister of the Supreme Court of  
 Queensland and the High Court of Australia  
 C S Johnson, BAppSc (Hons) (CompSc)  
 (NSWIT), MPhil (Brun)  
 K Sayer, BInf (Hons), PhD (Griff)  
 J Underwood, BSc (UNSW),  
 GradDipRecPlan, GradDipAdmin (CCAIE)  
 B Wong, BSc (Syd), MCom (UNSW), CQA,  
 MACS, AIMM, MQSA, JP

**Information Systems Technology**

*Senior Lecturer*

J Feuerlicht, BSc, DIC, PhD (Lond), MACS

*Lecturers*

J El-Den, BScCompEng, MScCompEng  
 (METU, Ankara)  
 E Lawrence, BA (Q'ld), GradDipComComp  
 (QUT), MBIT (USQ), MACS  
 R Raban, MEng (Warsaw)

**Administrative and technical staff**

*Executive Assistant*

K O'Toole, BSc (Hons), PhD (Syd)

*Administrative Assistant*

M Woessner

*Secretary*

L Chamas

*Desktop Publisher (Fixed Term)*

F M Morgan

*Director, Industry Liaison*

A Watkins MA (Hons) (Dundee), MBA  
 (Edinburgh)

*Engineer*

G Redwood, BE (Hons) (NSWIT)

*Computer Systems Administrator*

S B Gowing, BSc (UTS)

*Webmaster (Fixed Term)*

M R Lynch BA LLB (Macq)

*Systems Programmer*

B J Kuit

*Systems Programmer (Fixed Term)*

I L Woolf BAppSc (UTS)

*Senior Technical Officer*

B Power, E&C Cert (TAFE)

*Technical Officer*

Vacant

*Technical Officer (Fixed Term)*

W Yee BE (UNSW)

*Technical Assistant*

A Altman, Cert EE (Polytechnic Institute,  
 Odessa)

*Technical Assistant (Fixed Term)*

M Power

*Industrial Training Student*

Vacant

**Research staff**

*Postdoctoral Research Fellows*

K Englehardt, MSc, PhD (Kiel)

P A Steckler, MS (Computer Science), PhD  
 (Northeastern), MACM

*Research Scientist*

A Ghosh, BSc (Eng), MSc (Lond), MACM

*Research Assistants*

R De Silva, BSc (Hons) (Bond)

G McLarty, BSc (Hons) (UTS)

K Venkatesan, BSc, MCompSc (UNSW)

**Cooperative Research Centre for  
 Distributed Systems Technology  
 (DSTC)**

*Business Manager*

K H Dinh, BE (Hons) (Auck), PhD (UNSW)

*Systems Administrator*

V Witana

# Index

---

## A

Aboriginal Cultures and Philosophies 63, 147  
 Aboriginal Forms of Discourse 66, 151  
 Aboriginal People and the Media 65, 151  
 Aboriginal Social and Political History 65, 151  
 Acceptable behaviour 20  
 Accounting A 63  
 Accounting Information Systems 148  
 Advanced Algebra 60  
 Advanced Calculus 54  
 Advanced Case-based Reasoning 143  
 Advanced Computer Graphics Techniques 141  
 Advanced Corporate Finance 65  
 Advanced Data Management 140  
 Advanced Financial Modelling 62  
 Advanced Information Systems Modelling 140  
 Advanced Knowledge Technology 142  
 Advanced Machine Learning 142  
 Advanced Mathematical Methods 60  
 Advanced Mathematical Programming 61  
 Advanced Project Management 144  
 Advanced Stochastic Processes 61  
 Advanced Topics in Computing A 58  
 Advanced Topics in Computing B 59  
 Advances in Information Technology 145  
 Alphabetical list of subjects 81, 162  
 Analysis 1 56  
 Analysis 2 56  
 Analytic Number Theory 60  
 Applications Development with Delphi 139  
 Applications Development with Visual Basic 139  
 Applications of Information Technology 1 136  
 Applications of Information Technology 2 136  
 Applied Mathematics 3A 56  
 Applied Mathematics 3B 56  
 Applying for UTS courses 11  
 Artificial Intelligence Applications 134  
 Audiovisual Media Production 150  
 Auditing the Computer 137  
 Australian Studies 1 146  
 Austudy, eligibility for 22

## B

Bachelor of Computing 107  
 Bachelor of Computing/Bachelor of Arts in International Studies 108  
 Bachelor of Information Technology 98  
 Bachelor of Mathematics and Finance 39  
 Bachelor of Mathematics and Finance (Honours) 41  
 Bachelor of Mathematics and Finance/Bachelor of Arts in International Studies 42  
 Bachelor of Science (Honours) in Computing Science 105  
 Bachelor of Science (Honours) in Mathematics 35  
 Bachelor of Science in Computing Science 87  
 Bachelor of Science in Computing Science/Bachelor of Arts in International Studies 101  
 Bachelor of Science in Computing Science/Bachelor of Laws 104  
 Bachelor of Science in Mathematics 30  
 Bachelor of Science in Mathematics/Bachelor of Arts in International Studies 36  
 Boards and committees 165  
 Bridging Mathematics 26  
 Bridging subjects 26  
 Business Finance 64  
 Business Law 66  
 Business Process Transformation 134  
 Business Requirements Analysis 135  
 Business Systems Design 136

## C

Campus maps 7  
 Cantonese Language and Culture 67  
 Capacity Management 141  
 Capital Budgeting and Valuation (Honours) 64  
 Case-based Reasoning 134  
 Chinese Language and Culture 66  
 Chinese East Asia 76  
 Commercial Programming 133  
 Committees 165  
 Communication Technology 152  
 Computer Architecture 141  
 Computer Communication Systems 140  
 Computer Fundamentals 132  
 Computer Graphics 141  
 Computer Graphics 1 153  
 Computer Systems Architecture 130  
 Computers and Audiovisual Production 150  
 Computers and Print Production 150  
 Computing 1 54

Computing 2 55  
 Computing 3 58  
 Computing facilities 24, 84  
 Computing Literature, The 139  
 Computing Practice 130  
 Computing Seminar A 55  
 Computing Seminar B 55  
 Computing Seminar C 59  
 Computing Seminar D 59  
 Computing Theory 133  
 Contacts  
     Faculty Office 17  
     School of Computing Sciences 86  
     School of Mathematical Sciences 28  
 Contemporary China 76  
 Contemporary Europe 77  
 Contemporary Information  
     Technology 1 133  
 Contemporary Information  
     Technology 2 135  
 Contemporary Japan 76  
 Contemporary Latin America 77  
 Contemporary Management Practices 147  
 Contemporary South-East Asia 76  
 Contemporary Telecommunications 145  
 Convexity and Optimisation 60  
 Course Advisory Committees 166  
 Courses  
     List 23, 83  
     Postgraduate 45, 109  
     Preparation 26  
     Undergraduate 30, 87  
 Croatian 76

**D**

Database Design 131  
 Dean's message 14  
 Derivative Securities 64  
 Derivative Security Pricing 65  
 Design and Analysis of Experiments 57  
 Design of Hypermedia Information  
     Systems 149  
 Differential Equations 54  
 Discrete Mathematics 54  
 Discrete Optimisation 61  
 Distributed Databases and Client/Server  
     Computing 131, 142  
 Distributed Software Programming 138, 144  
 Doctor of Philosophy 46, 110  
 Double degree in Business and Computing  
     Sciences 105  
 Dynamic Optimisation 61

**E**

Effective People Management 147  
 Exemptions, student 27

**F**

Faculty Board in Mathematical and  
     Computing Sciences 165  
 Faculty Graduate Studies Committee 165  
 Faculty information 14  
 Faculty Mission Statement 15  
 Financial Markets 64  
 Financial Modelling 59  
 Financial Time Series Analysis 64  
 Financing Decisions and Capital Market  
     Theory 64  
 Formal Reasoning for Software  
     Development 140  
 French Language and Culture 73  
 Functional Analysis 60  
 Fundamentals of Human-Computer  
     Interaction 136

**G**

German Language and Culture 73  
 Graduate Certificate in Human-Computer  
     Interaction 127  
 Graduate Certificate in Information  
     Technology 128  
 Graduate Certificate in Information  
     Technology Management 118  
 Graduate Certificate in Interactive  
     Multimedia 122  
 Graduate Certificate in Internetworking 124  
 Graduate Certificate in Mathematical  
     Sciences 51  
 Graduate Certificate in Software Quality  
     Assurance 129  
 Graduate Diploma in Applicable  
     Mathematics 48  
 Graduate Diploma in Information  
     Technology 125  
 Graduate Diploma in Information  
     Technology Management 118  
 Graduate Diploma in Interactive  
     Multimedia 122  
 Graduate Diploma in Internetworking 124  
 Graduate Diploma in Mathematics and  
     Finance 48  
 Graduate Diploma in Operations  
     Research 49  
 Graduate Diploma in Statistics 50  
 Graduation ceremonies 21  
 Graphic Visualisation 153  
 Greek 75

**H**

History of Mathematics 54  
 Honours Research Project 139  
 Honours Seminar 1 139  
 Honours Seminar 2 139  
 Honours Seminar A 62  
 Honours Seminar B 62

Human Factors and Design 153  
 Human-Computer Interaction 135  
 Human-Computer Interaction in  
 Information Systems 142  
 Human-Computer Interaction Tools and  
 Techniques 136  
 Hypermedia Technologies 148

**I**

Impact of Information Technology 144  
 Implementation of Human-Computer  
 Interaction 137  
 In-country Study 1 77  
 In-country Study 2 77  
 Indonesian Language and Culture 70  
 Industrial Training (F/T) 133  
 Industrial Training (P/T) 133  
 Industry Project 1 135  
 Industry Project 2 136  
 Information Behaviour 152  
 Information Centres 11  
 Information, Faculty 14  
 Information for students 16  
 Information Management 141  
 Information Processing Strategy 141  
 Information Production and  
 Presentation 152  
 Information Retrieval 152  
 Information Structures, Perception and  
 User Interface Design 148  
 Information Systems 130  
 Information Systems and Organisations 134  
 Information Technology Division (ITD)  
 facilities 84  
 Information Technology Environment 141  
 Information Technology Planning and  
 Design 132  
 Information Technology Strategy 135, 145  
 Integrated Services Network 148  
 International Financial Management 64  
 International Studies, Electives 20  
 International Studies subjects 66, 153  
 Internet Programming 143  
 Internetwork Design 144  
 Internetworking 143  
 Internetworking Project 143  
 Internetworking Research 143  
 Introduction to Computer Graphics 129  
 Introduction to Computers for Beginners 26  
 Introduction to Computing 54  
 Introduction to Computing Research 139  
 Introduction to Design Computing 153  
 Introduction to Statistics 26  
 Introductory Mathematical Methods 53  
 Investment Analysis (Honours) 65  
 Italian Language and Culture 74

**J**

Japanese Language and Culture 69

**K**

Knowledge Technology 129  
 Knowledge-based Systems 134

**L**

Languages and Translators 133  
 LANs and Routing 143  
 Linear Algebra 54  
 Linear Models and Experimental Design 61  
 List of courses and codes 23  
 Loglinear Modelling 61

**M**

Machine Learning 134  
 Macroeconomics 63  
 Malaysian Language and Culture 72  
 Management Research Methods 147  
 Managerial Analysis and Evaluation of  
 Information Systems 144  
 Managing Client Relations 148  
 Managing Organisational Change 147  
 Marketing Principles 148  
 Master in Interactive Multimedia 122  
 Master in Internetworking 124  
 Master of Business in Information  
 Technology Management 118  
 Master of Science 46, 111  
 Master of Science in Computing 113  
 Master of Science in Operations Research 47  
 Mathematica 27  
 Mathematical Methods 56  
 Mathematical Practice 53  
 Mathematical Programming 1 55  
 Mathematics 1 53  
 Mathematics 2 53  
 Mathematics for Computing 53  
 Mathematics major 32  
 Mathematics Preparation for Nursing 26  
 Mathematics Study 1, 2, 3 26  
 Mathematics Study Centre 25  
 Mathematics Tutorial 1, 2, 3 26  
 Mathematics Workshop 1, 2, 3, 4, 5, 6 26  
 Media, Culture and Society 150  
 Media Studies 149  
 Message from the Dean 14  
 Microeconomic Theory and Policy 64  
 Microeconomics 63  
 Mono Media Technologies 149  
 Multimedia Industry and Process 146  
 Multimedia Products and Technology 146  
 Multimedia Project 147  
 Multivariate Statistics 61

**N**

NetDesign 151  
 Network Management 138  
 Network Optimisation 57  
 Networking 1 132  
 Networking 2 132  
 Nonlinear Dynamical Systems 60  
 Nonlinear Statistical Models 61  
 Numerical Analysis 1 55  
 Numerical Analysis 2 59  
 Numerical list of subjects 78, 154

**O**

Object-oriented Methodologies 138  
 Object-oriented Programming and C++ 136  
 Object-oriented Software Development 140  
 Objectbases 138  
 Operating Systems 132, 141  
 Operating Systems Facilities 137  
 Operations Research Practice 56  
 Optimal Control 1 62  
 Optimal Control 2 62  
 Optimisation 1 55  
 Optimisation 2 57  
 Organisation of Information 152

**P**

Paradigms of Intelligence 138  
 Parallel Programming 137  
 Partial Differential Equations 60  
 Performance Modelling 138  
 Photography for Designers 153  
 Polish 76  
 Politics of Aboriginal History, The 66, 151  
 Postgraduate courses 45, 109  
 Postgraduate coursework programs 47, 113  
 Postgraduate research degrees 45, 109  
 Preparation courses 26  
 Principles dates for 1998 12  
 Principles of Object-oriented Programming in C++ 142  
 Principles of Object-oriented Programming in Smalltalk 142  
 Principles of Software Development A 130  
 Principles of Software Development B 130  
 Prizes 27, 85  
 Probability and Stochastic Processes 57  
 Procedural Programming 131  
 Programming Fundamentals 132  
 Programming on the Internet 134  
 Project 55, 63, 129, 137, 146  
 Project (1 semester) 129  
 Project (2 semesters) 129  
 Project A 145  
 Project B 145  
 Project Management 135  
 Project Management and the Professional 131  
 Pure Mathematics 3A 55  
 Pure Mathematics 3B 56

**Q**

Quality Control 57  
 Quantitative Modelling 131

**R**

Recent Advances in Computer Science 145  
 Recent Advances in Information Systems 145  
 Regression Analysis 57  
 Report 63  
 Resources Management for IT Professionals 135  
 Russian 75

**S**

Scheduling Theory 61  
 Scholarships 85  
 School Advisory Committees 166  
 School contacts 28, 86  
 School of Computing Sciences 83  
   Academic advisers for 1998 83  
   Advisory Committee 166  
   Alphabetical list of subject 162  
   Contacts 86  
   International Studie 153  
   ITD facilities 84  
   Numerical list of subjects 154  
   Postgraduate courses 109  
   Postgraduate coursework programs 113  
   Postgraduate research programs 109  
   Prizes 85  
   Scholarships 85  
   Subject descriptions 129  
   Subjects offered by other faculties 146  
   Undergraduate courses 87  
 School of Mathematical Sciences 24  
   Advisory Committee 166  
   Alphabetical list of subjects 81  
   Computing facilities 24  
   Contacts 28  
   International Studies subjects 66  
   Mathematica 27  
   Mathematics Study 25  
   Numerical list of subjects 78  
   Postgraduate courses 45  
   Prizes 27  
   Subject descriptions 53  
   Subjects offered by other faculties 63  
   Undergraduate courses 30  
 Seminar (Computing) 59  
 Seminar (Mathematics) 59  
 Seminar (Operations Research) 59  
 Seminar (Statistics) 59  
 Simulation Modelling 57  
 Slovenian 76  
 Smalltalk 138  
 Software Development Case Study 132  
 Software Quality Assurance 139

Software Quality Management 144  
 Software Quality Management Systems 142  
 Sound and Image 150  
 Sound Design 151  
 Sound, Music, Noise 149  
 Sound Studies 150  
 Spanish Language and Culture 74  
 Specialist Topics in Artificial Intelligence 140  
 Staff list 168  
 Statement of good practice and  
     ethics in informal assessment 20  
 Statistical Consulting 62  
 Statistical Inference 57  
 Statistics 1 54  
 Statistics 2 55  
 Stochastic Methods in Operations  
     Research 57  
 Strategic Business Management 148  
 Strategic IT Contract Management 145  
 Students, Information for 16  
 Subjects,  
     Alphabetical list of 81, 162  
     Bridging 26  
     Descriptions of 53, 129  
     Exemptions 27  
     International Studies 66, 153  
     Numerical list of 78, 154  
     Offered by other faculties 63, 146  
 Systems Design 132  
 Systems Design and Development 131  
 Systems Integration 144  
 Systems Modelling 130  
 Systems Programming 137  
 Systems Software and Networks 131

**T**

Teletraffic Engineering 148  
 Thai 72  
 Theories of the Visual 149  
 Theory of Financial Decision Making 65  
 Thesis 65  
 Thesis (Honours) 62  
 Thesis Seminar A 62  
 Thesis Seminar B 62  
 3D Computer Animation 1 153  
 3D Computer Animation 2 153  
 Time Series Analysis 62  
 Tool-based Systems Development 142  
 Topics in Computer Graphics 129  
 Total Quality and Productivity  
     Management 147  
 2D and 3D Communication 153

**U**

Ukrainian 76  
 Unacceptable behaviour 21  
 Undergraduate courses 30, 87  
 University Statistical Consulting Service 25  
 Unix Systems Administration 143  
 User Documentation 1 152  
 User Documentation 2 152

**V**

Video Basic 150



**University of Technology, Sydney**

PO Box 123

Broadway NSW 2007

Australia

Telephone (02) 9514 2000

**Course inquiries within Australia**

Information Service (02) 9514 1222

email [info.office@uts.edu.au](mailto:info.office@uts.edu.au)

**International inquiries**

International Programs +61 2 9514 1531

email [intlprograms@uts.edu.au](mailto:intlprograms@uts.edu.au)

**World Wide Web** <http://www.uts.edu.au>

ISSN 1328-9268

Price