

378.94405
NEW
18
1998
Copy 3



U T S

UTS LIBRARY



3 2007 00053818 8

NOT
FOR
LOAN

Faculty of

Law

Handbook



University of Technology, Sydney

1999

University of Technology,
Sydney. Faculty of Law.
Faculty of Law handbook
Received on: 30-01-98
CITY REFERENCE GREEN
University of Technology,
Sydney Library

***UTS Faculty of
Law
Handbook
1998***

The University attempts to ensure that the information contained in this handbook is correct as at 28 November 1997. The University reserves the right to vary any matter described in the handbook at any time without notice.



University of Technology, Sydney

Equal opportunity

It is the policy of the University of Technology, Sydney to provide equal opportunity for all persons regardless of sex, race, marital status, family responsibilities, disability, sexual preference, age, political conviction or religious belief.

Free speech

The University supports the right to freedom of speech and the rights of its members to contribute to the diversity of views presented in our society.

Non-discriminatory language

UTS has adopted the use of non-discriminatory language as a key strategy in providing equal opportunity for all staff and students. Guidelines for the use of non-discriminatory language have been developed and all members of the University community are encouraged to use them.

Editorial and production:

Publications Branch,
Registrar's Division

Cover

UTS – The Global Classroom
UTS congratulates our first group of International Studies students who will spend 1998 studying overseas in the country of their choice.

External Relations Unit

Table of contents

General University information	5
Preface	5
Addresses and telephone numbers	6
Campus maps	7
Applying for UTS courses	11
UTS Information Centres	11
Principal dates for 1998	12
Faculty information	14
Faculty Mission Statement	14
Message from the Dean	14
Inquiries	15
Information for students	16
Prizes and scholarships	18
List of courses and codes	19
Undergraduate courses	20
Course information and inquiries	20
Bachelor of Laws	27
Bachelor of Laws in Australian Indigenous Law	30
<i>Double degrees</i>	32
Bachelor of Business/Bachelor of Laws	32
Bachelor of Science in Computing Science/Bachelor of Laws	33
Bachelor of Arts/Bachelor of Laws	34
Bachelor of Science/Bachelor of Laws	36
Bachelor of Medical Science/Bachelor of Laws	36
<i>New Double degrees</i>	37
Bachelor of Arts in Communication (Journalism)/Bachelor of Laws	37
Bachelor of Arts in Communication (Media Arts and Production)/ Bachelor of Laws	38
Bachelor of Arts in Social Science/Bachelor of Laws	39
<i>Combined degrees</i>	40
Bachelor of Laws/Bachelor of Arts in International Studies	40
<i>Undergraduate supply programs</i>	42
Postgraduate courses	44
Course information and inquiries	44
Doctor of Philosophy	48
Doctor of Juridical Science	49
Master of Laws (by thesis)	51
Master of Laws (by coursework)	52
Master of Dispute Resolution	53
Graduate Certificate in Dispute Resolution	55
Master of Taxation Law	56
<i>Practical Legal Training courses (Professional Program)</i>	58
Graduate Certificate in Legal Practice (Stage 1)	58
Graduate Certificate in Continuing Legal Practice (Stage 2)	59

Graduate Diploma in Australian Law	59
Master of Comparative Law	60
Graduate Certificate in Comparative Law	61
Master of Legal Studies	62
Graduate Diploma in Legal Studies	63
Graduate Diploma in Law for Secondary Teachers	64
Graduate Certificate in Law for Secondary Teachers	64
<i>Postgraduate supply programs</i>	65
External award study	66
Extension (non-award) study	67
Subject descriptions	68
Undergraduate subjects	68
Postgraduate subjects	92
Undergraduate supply subjects	114
Subjects offered by other faculties	122
Alphabetical list of subjects	123
Centres within the Faculty	126
Boards and committees	129
Faculty Board in Law	129
Faculty of Law Advisory Committee	129
Research interests of staff	130
Staff list	132
Index	135

General University information

PREFACE

Welcome to the University of Technology, Sydney (UTS), the fourth largest university in New South Wales. UTS has a reputation for delivering quality higher education that meets the needs of the professions, the technologies and the community. It is a multicampus university operating at three major locations in the Sydney metropolitan area – Broadway, Kuring-gai and St Leonards – and offering over 80 undergraduate and 200 postgraduate courses to nearly 22,000 students.

The main work of course development and delivery at UTS is carried out by the Faculties of Business; Design, Architecture and Building; Education; Engineering; Humanities and Social Sciences; Law; Mathematical and Computing Sciences; Nursing; and Science; and the Institute for International Studies. Each of these is responsible for a range of programs across a number of key disciplines.

Every year UTS produces 10 faculty/institute handbooks containing information about all the courses and subjects offered at UTS, and including details of course content, attendance patterns, credit point requirements and combined degrees, plus important faculty and student information.

These handbooks are part of a suite of publications which includes the *UTS Calendar* and the postgraduate and undergraduate student handbooks. The *UTS Calendar* contains the University Act, By-law and Rules, a list of courses offered at the University, and other useful University information. Copies are held in the University's libraries and faculty offices, and may be purchased at the Co-op Bookshop. The student handbooks contain general information about application procedures, academic progression, assistance schemes, and services and facilities offered to students. You will be given a free copy of one of these when you enrol.

If you need more information about the University or its courses, you can contact the UTS Information Service or your faculty office. The University provides a whole range of services for students, and there are plenty of qualified people here to give you help and advice.

We hope you enjoy your time as a student at UTS, and wish you well in your studies.

ADDRESSES AND TELEPHONE NUMBERS

University of Technology, Sydney

Postal address

PO Box 123
Broadway
NSW 2007 Australia

Telephone

(02) 9514 2000
International: +61 2 9514 2000
Fax: (02) 9514 1551

World Wide Web

<http://www.uts.edu.au>

City campus

Broadway

- Building 1 (Tower Building)
1 Broadway, Ultimo
- Building 2
1 Broadway, Ultimo
- Building 3 (Bon Marche Building)
Cnr Harris St and Broadway, Ultimo
- Building 4
Cnr Thomas and Harris Streets, Ultimo
- Building 6
702–730 Harris St, Ultimo
- Broadway Terraces
9, 11 and 13 Broadway, Ultimo
- Magic Pudding Childcare Centre
Thomas St, Ultimo

Haymarket

- Building 5
Cnr Quay St and Ultimo Rd, Ultimo

Blackfriars

- Cnr Blackfriars and Buckland Steets,
Chippendale
- Blackfriars Childrens Centre
Buckland St, Chippendale

Smail Street

- 3 Smail St, Ultimo

Wembley House

- 839–847 George St, Sydney

Harris Street

- 645 Harris St, Ultimo

Student housing

- Bulga Ngurra
23–27 Mountain St, Ultimo
- Geegal
82–84 Ivy St, Ultimo

Australian Technology Park Sydney Ltd

Institute for Sustainable Futures

- Suite 213
National Innovation Centre
Cnr Garden, Cornwallis and Boundary
Streets
Eveleigh NSW 1430
Telephone: (02) 9209 4350
Fax: (02) 9209 4351

Kuring-gai campus

- Eton Rd, Lindfield
(PO Box 222, Lindfield NSW 2070)

St Leonards campus

- Dunbar Building
Cnr Pacific Highway and
Westbourne St, Gore Hill
- Clinical Studies Building, Centenary
Lecture Theatre and West Wing
Reserve Rd, Royal North Shore Hospital
- Gore Hill Research Laboratories
Royal North Shore Hospital

Yarrawood conference and research centre

- 689 Springwood Rd
Yarramundi NSW 2753

Stroud Field Station

- 2605 The Bucketts Way
Booral NSW 2425

CAMPUS MAPS

City campus

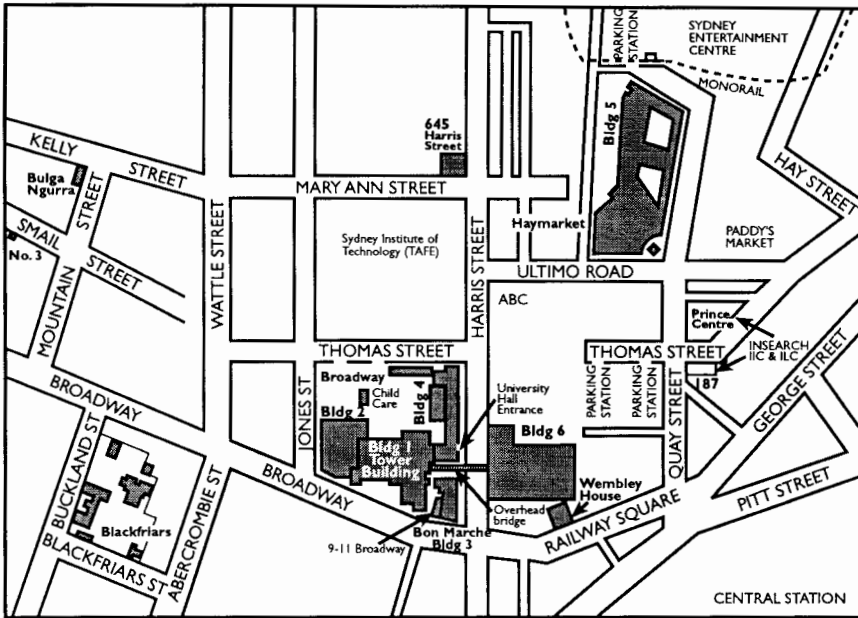

Broadway

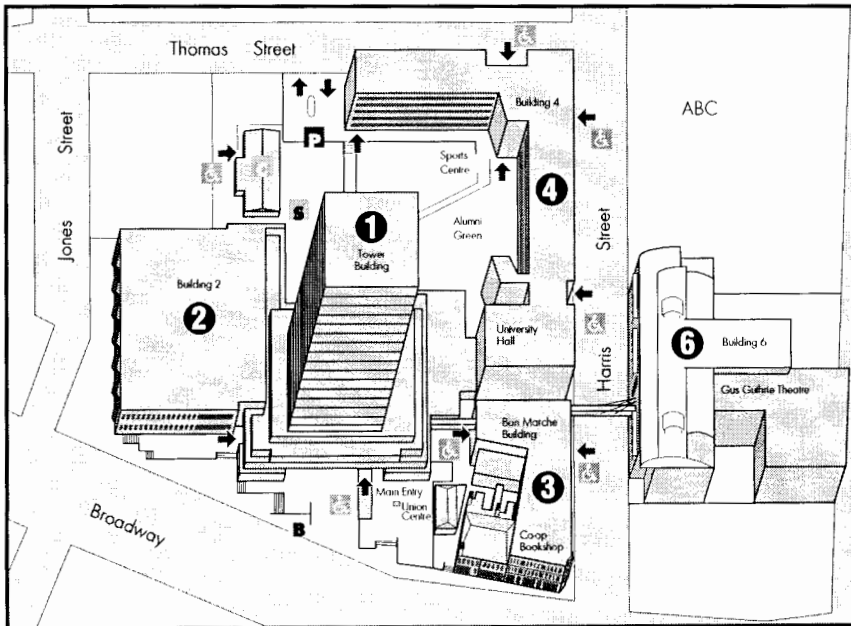

Haymarket

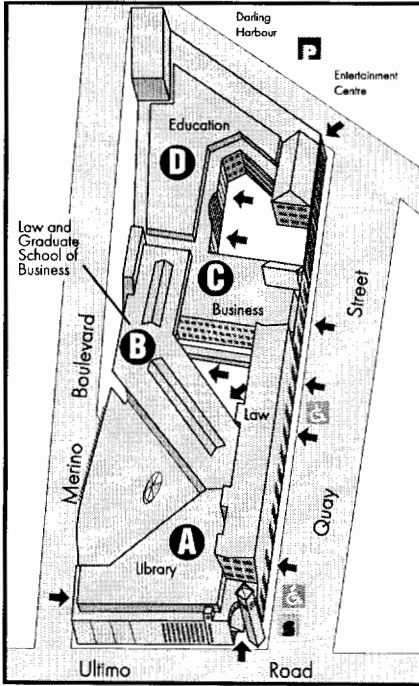

KEY

- ➔ Entry/Exit
- ♿ Disabled access
- B** Main bus stop
- 🚌 UTS shuttle bus
- P** Parking
- 1** Building numbers
- 👶 Child care

Blackfriars

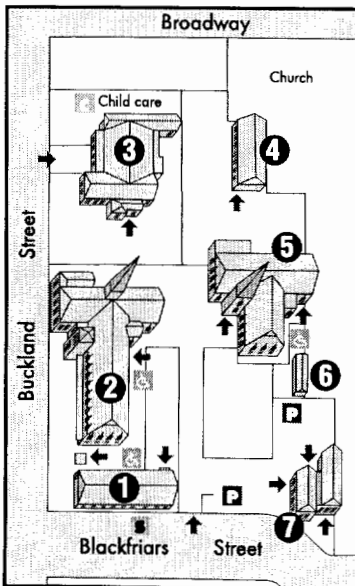

Kuring-gai campus

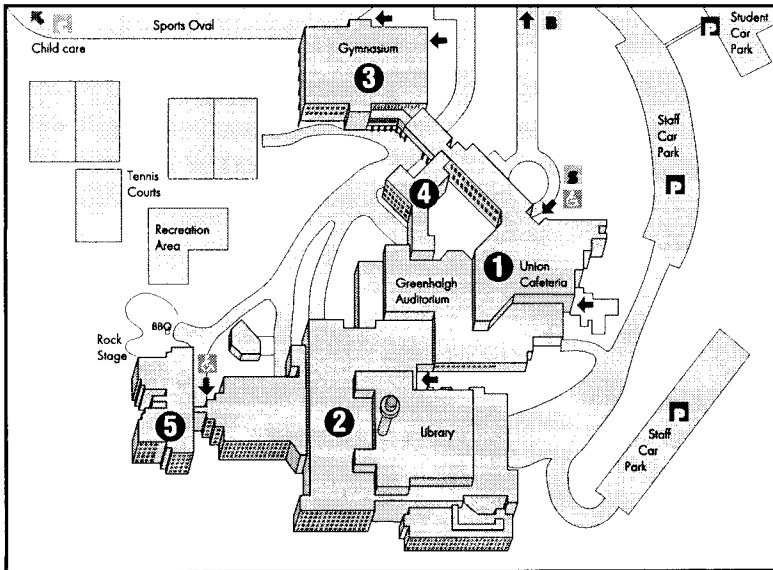
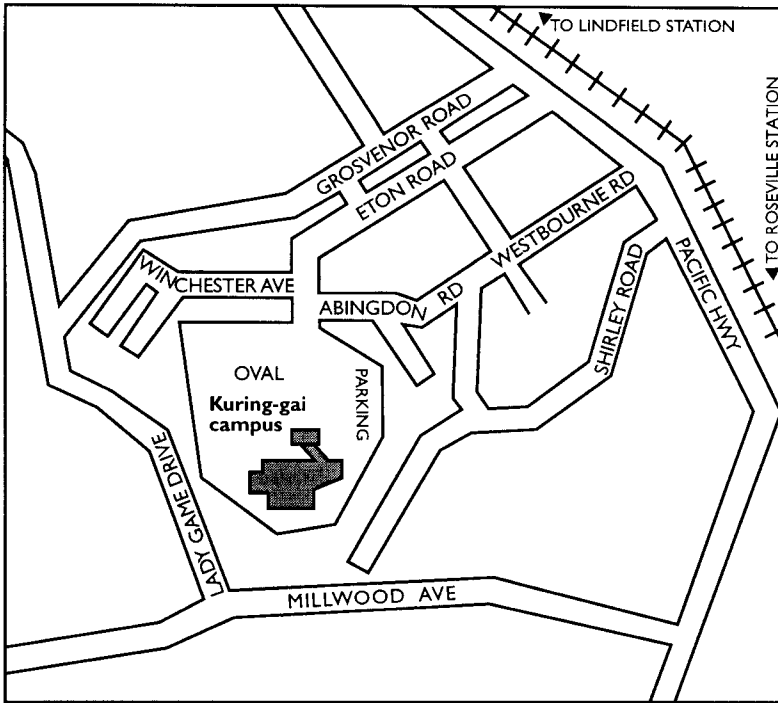

St Leonards campus

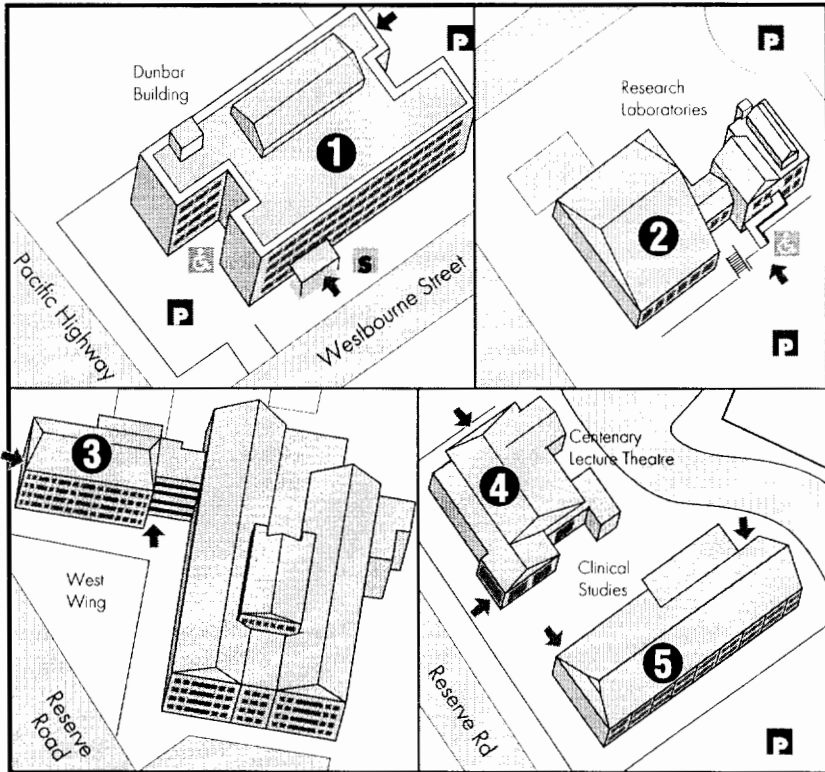
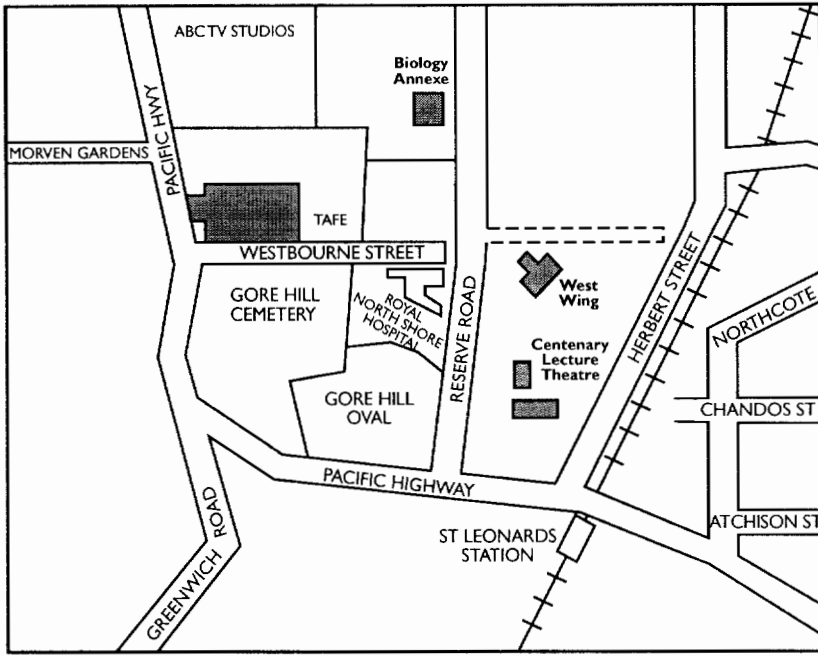

APPLYING FOR UTS COURSES

Undergraduate

Applications for the majority of those undergraduate courses which start at the beginning of each year must be lodged through the NSW and ACT Universities Admissions Centre (UAC) between August and October. Please check the application requirements in the *UAC Guide*, as some of these courses close for applications at the end of September. Some courses are also available by direct application to UTS. These are usually courses that are not available to school leavers.

A small number of UTS courses also start in the middle of the year. Applications for these should be made direct to UTS in May.

Contact the UTS Information Centres for more information.

Postgraduate

Applications for postgraduate courses should be made direct to UTS. For courses starting at the beginning of the year, most applications are open from August to October, but some may have earlier closing dates. For courses

starting in the middle of the year, applications close in May.

Contact the UTS Information Centres for more information.

Non-award and External Award study

Non-award and External Award study allows individuals and students from other universities to study single subjects at UTS. There are four application periods, and closing dates are different for each of the semesters. Some faculties may have special application procedures which will vary depending on the subjects chosen.

Contact the UTS Information Centres for more information.

International students

International students need to satisfy the normal UTS entry requirements and be proficient in English. For details on courses, fees and application procedures, contact International Programs.

UTS INFORMATION CENTRES

Street address	Postal address	Telephone/Fax
<i>City campus</i>		
Foyer, Tower Building 1 Broadway	UTS Information Service PO Box 123 Broadway NSW 2007	Telephone: (02) 9514 1222 Fax: (02) 9514 1200
<i>Kuring-gai campus</i>		
Level 5 or 6, Main Building Eton Road Lindfield	Kuring-gai Student Centre PO Box 222 Lindfield NSW 2070	Telephone: (02) 9514 5555 Fax: (02) 9514 5032
<i>International Programs</i>		
Level 5, Tower Building 1 Broadway	International Programs PO Box 123 Broadway NSW 2007	Telephone: (02) 9514 1531 Fax: (02) 9514 1530

Email inquiries

Within Australia – info.office@uts.edu.au

International – intlprograms@uts.edu.au

PRINCIPAL DATES FOR 1998

Autumn semester

January

- 2 Release of HSC results
- 9 Formal supplementary examinations for 1997 Spring semester students
- 9 Closing date for changes of preference to UAC from 1997 NSW and ACT HSC applicants
- 16 Final examination timetable for Summer session
- 23 Main round of offers to UAC applicants
- 26 Australia Day – public holiday
- 26 Public school holidays end
- 28 Closing date for changes of preference to UAC for final round offers
- 28-30 Enrolment of new undergraduate students at City campus (and 2-4 February)

February

- 2 Last day for continuing students to pay their 1998 service fees
- 2-4 Enrolment of new undergraduate students at City campus (and 28-30 January)
- 6 Final round of offers (UAC)
- 2-13 Formal examinations for Summer session
- 23 Release of results for Summer session
- 5-26 Enrolment of students at City campus

March

- 2 Classes begin
- 4-5 Enrolment (External award, Non-award and Exchange students)
- 13 Last day to enrol in a course or add subjects
- 20 Last day to pay HECS
- 30 Last day to apply to graduate in Spring semester 1998
- 31 Last day to apply for leave of absence without incurring student fees/charges¹
- 31 Last day to withdraw from a subject without financial penalty¹
- 31 HECS census date

April

- 9 Last day to withdraw from a course or subject without academic penalty¹
- 9 Public school holidays begin
- 10 Good Friday
- 13-17 Vice-Chancellors' Week (non-teaching)
- 14-17 Graduation (Kuring-gai)
- 24 Provisional examination timetable available
- 25 Anzac Day – public holiday
- 27 Public school holidays end

May

- 1 Applications available for undergraduate courses where applicable
- 1 Applications open for available postgraduate courses for Spring semester 1998
- 4-15 Graduation (City)
- 15 Examination masters due
- 29 Closing date for undergraduate and postgraduate applications for Spring semester
- 29 Final examination timetable

June

- 8 Queen's Birthday – public holiday
- 12 Last teaching day of Autumn semester
- 13-30 Formal examination period (and 1-3 July)

July

- 1-3 Formal examination period (and 13-30 June)
- 3 Autumn semester ends
- 3 Public school holidays begin
- 6-10 Vice-Chancellors' Week (non-teaching)
- 13-17 Formal alternative examination period for Autumn semester students
- 20 Public school holidays end
- 24 Release of Autumn semester examination results; two days earlier via UniPhone™
- 27 Formal supplementary examinations for Autumn semester students

Spring semester

August

- 3 Classes begin
- 3 Applications available for undergraduate and postgraduate courses for Autumn semester 1999
- 7 Last day to withdraw from full year subjects without academic penalty¹
- 14 Last day to enrol in a course or add subjects
- 31 Last day to apply for leave of absence without incurring student fees/charges (Spring enrolments only)¹
- 31 Last day to withdraw from a subject without financial penalty¹
- 31 Last day to apply to graduate in Autumn semester 1999
- 31 HECS census date

September

- 11 Last day to withdraw from a course or subject without academic penalty¹
- 25 Provisional examination timetable available
- 25 Public school holidays begin
- 28 Vice-Chancellors' Week (non-teaching) begins
- 28-30 Graduation (City)
- 30 Closing date for undergraduate applications via UAC (without late fee)
- 30 Closing date for inpUTS Special Admission Scheme applications

October

- 1-2 Graduation (City)
- 2 Vice-Chancellors' Week (non-teaching) ends
- 5 Labour Day – public holiday
- 12 Public school holidays end
- 16 Examination masters due
- 30 Final examination timetable available
- 30 Closing date for undergraduate applications via UAC (with late fee)

- 30 Closing date for undergraduate applications direct to UTS (without late fee)
- 30 Closing date for most postgraduate courses for Autumn semester 1999 (some courses may have earlier closing dates in September)
- 30 Closing date for Australian Postgraduate Awards, the R L Werner and University Doctoral scholarships

November

- 13 Last teaching day of Spring semester
- 14-30 Formal examination period (and 1-4 December)
- 30 Closing date for Undergraduate applications via UAC (with late fee)

December

- 1-4 Formal examination period (and 14-30 November)
- 4 Spring semester ends
- 14-18 Formal alternative examination period for Spring semester students
- 18 Public school holidays begin
- 21 Release of Spring semester examination results; two days earlier via UniPhone™

¹ HECS/Postgraduate course fees will apply after the HECS census date (31 March and 31 August or last working day before).

Note: Information is correct as at 6 November 1997. The University reserves the right to vary any information described in Principal Dates for 1998 without notice.

Faculty information

FACULTY MISSION STATEMENT

The Faculty of Law provides higher education with a professional perspective in the discipline of law at the undergraduate, graduate and postgraduate levels.

The Faculty is concerned to further the intellectual development and professional skills of students by initiating and encouraging critical analysis of legal institutions, legal theories and reasoning, principles and practices; their utilisation and their impact upon the rights and obligations of individuals, government, business, professional practice and the interests of a wider society. It is committed to the furtherance of scholarship and research into legal issues and practices; to participation in discussion and debate concerned with legal theory, legal procedures, the rule of law and the effectiveness of the legal system in societies; and to the dissemination and publication of its contribution in these areas.

The Faculty is concerned to initiate and respond to critical developments and challenges, in particular those posed by new technologies, and their interpretation and application in legal contexts; and to familiarise academic staff, members of the profession and students with the changing technological environment, and equip them to utilise new methods and tools for information gathering, storage, retrieval and analysis.

The Faculty provides specialist law teaching in diverse law programs in order to build upon skills, knowledge and expertise in the discipline of law, and in other professional disciplines that need to understand the legal implications and environment of their professional practice.

The emphasis is upon practical legal education and the enhancement of legal practice. It provides formal training and professional qualifications on behalf of the relevant admitting authority to applicants seeking admission to practise as solicitors.

MESSAGE FROM THE DEAN

I welcome all students, staff and visitors in 1998.

The Faculty of Law had its beginnings in 1975 when the then NSW Institute of Technology was invited by the NSW Government to offer an undergraduate course in law. Elements of that course have stood the test of time, and may be distinguished in a number of aspects from other law degrees. These include a strong professional core, a commitment to the development of professional skills and a willingness to accommodate the needs of mature students, particularly those in employment.

The Faculty has since developed combined and double degree programs and also offers graduate programs, including the Master of Laws (by coursework) and the SJD (Doctor of Juridical Science), which was the first of its kind in Australia. Through its International and Commercial Law Centre, besides publishing its own law journal the Faculty also publishes *Lawasia* and the *Australian International Law News*.

In 1990, as a result of the merger of UTS with the Kuring-gai College of Advanced Education, the Departments of Business Law in the City and Legal Studies at Kuring-gai were incorporated with the Faculty. This meant that the new Faculty would also undertake supply programs in other faculties, particularly the Faculty of Business. The Faculty was also able to deliver Practical Legal Training through its affiliation with the College of Law at St Leonards between 1990 and 1995.

1996 was a year of change for the Faculty, with major revisions to the undergraduate Law degree and the introduction of the legal practice major as an integral part of the undergraduate program, with progression into the new Graduate Diploma in Legal Practice to complete legal training. With its provision of 'One Stop Legal Education', the Faculty is now recognised as a major innovator of legal education.

Since 1997, the Faculty has been in new accommodation at the Haymarket campus. This incorporates a modern moot court and two practice courts within the greatly enhanced facilities.

Improved computer laboratories have afforded the Faculty the opportunity to exploit its expertise within the increasingly important area of legal technology.

During 1997, in addition to the opening of the new premises, the Faculty celebrated 20 years of teaching at UTS, as well as hosting the Australasian Law Teachers Association Conference and a major AustLII Legal Information Technology Conference.

I wish you every success and trust that your stay with us is both enjoyable and productive.



David Barker
Dean

INQUIRIES

Correspondence should be addressed to:

The Faculty of Law
University of Technology, Sydney
PO Box 123
Broadway, NSW 2007
Telephone: 9514 3444
DX 11560 Sydney
Down Town

The Faculty Information Office is located at:

Room B303
Level 3, B Block
Haymarket
Corner of Quay Street and Ultimo Road

Internet addresses

Faculty homepage

<http://www.law.uts.edu.au/>

Professional Program homepage

<http://www.plt.law.uts.edu.au/>

INFORMATION FOR STUDENTS

The Faculty of Law was formally established in 1975 and began teaching in 1977. The Faculty is located at the City and Kuring-gai campuses, and offers a variety of undergraduate and postgraduate courses. The Faculty also supplies subjects in Business Law and Legal Studies. The undergraduate courses provide opportunities for full- and part-time study for those wishing to obtain professional qualifications in law.

Notices

Official University notices are displayed on the noticeboards on Level 1 of the Faculty of Law at Haymarket in the City campus, and Level 4 of the Kuring-gai campus; students are required to be acquainted with the contents of those announcements that concern them. Misreading or misunderstanding of official information will not be accepted as a reason for a student being unaware of matters so notified.

Parking

At Haymarket in the City campus, the car park in Quay Street, opposite the Library, may have limited parking space available for students after 3.00 p.m. Kings car park and the Apple car park offer discounted student parking. Other commercial parking facilities are available at Her Majesty's Theatre, Paddy's Markets and the Entertainment Centre. Student parking is available on the Kuring-gai campus for a fee.

Law Students' Society

The Law Students' Society (LSS) is governed by a Council of 12 student members, elected at the Society's Annual General Meeting held at the beginning of the Autumn semester each year. The Council in turn elects an Executive consisting of the President, Vice-President, Treasurer, ALSA (Australasian Law Students' Association) Representative and Secretary. The Council meets on a fortnightly basis during each semester to review the Society's activities and discuss new initiatives. Justice Mary Gaudron of the High Court of Australia is one of two patrons, the other being Professor David Flint, former Dean of the Faculty of Law. Interest and input are encouraged from students; many of the ideas acted upon come from members.

Social functions are an important part of university life and the LSS regularly organises functions for students. Popular events include the annual Black Tie Ball in May and a variety of 'drinks nights' throughout each semester. The Society can also assist in organising functions that students wish to hold.

Services to members

Past exam papers

The Society provides members with copies of past exam papers in each core subject to enable preparation for final examinations.

Legislation service

The Society can acquire both State and federal legislation on behalf of members from government printing offices.

Secondhand bookshop

The Society operates a secondhand bookshop through which members may buy and sell textbooks.

Mooting competition

The Society conducts an internal mooting competition in the Autumn semester each year to select representatives for participation in intervarsity competitions.

Affiliation with ALSA

The Society is affiliated with the Australasian Law Students' Association (ALSA), the Asian-Pacific body representing Law students. As a result, members receive copies of the *Reporter* (quarterly journal) and *Decisions* (careers journal) publications, and may attend its annual eight-day conference in July.

Student representation

The Society is often requested to provide students' views on matters relating to the LLB program and to provide student input on various committees. The LSS also acts as a communication channel between the Faculty and the student body. The Society provides advocacy services and other assistance with academic appeals.

Monthly publication

The LSS is responsible for the monthly publication of the *Full Bench* magazine. This provides an outlet for the Council to communicate with its members. Also, members may submit articles of interest, either social, academic or education-based. These will be reviewed for inclusion by the Council.

Full Bench reports upon the recent and upcoming social events of the Law Student's Society and any education issues which are relevant to Law students. Recently, the publication has included articles of social comment, allowing members to air their views.

Recent achievements

In 1994, the LSS introduced an information service on topics such as the College of Law, Summer Clerkships, Honours, and study and exam techniques. The LSS has also been successful in obtaining better resources for the library and regularly donates books that are in heavy demand. Important improvements to the Business/Law and Science/Law courses have been negotiated by the LSS over the past few years, leading to greater equity and opportunity in courses.

In 1995, the LSS sent a team to compete at ALSA. The mooting team reached the semifinals, the client interviews placed seventh, and the witness examiner placed twelfth in Australasia.

In 1996, the LSS has produced a number of publications to assist members. These include a Summer Clerk Application Guide and a mooting guide. The Society has also been instrumental in negotiating for reduced class sizes.

1996 has seen the instigation of an avenue for student complaints. Students may make a written submission which the LSS will bring to the attention of the Faculty. In addition, a complaints forum is to be held with representatives from the LSS and Faculty present.

Membership fees are currently \$10 per annum. Further details are obtainable from the LSS Office (Room B113 at Haymarket in the City campus) or by telephoning 9514 3448. A list of Council members is posted on the LSS noticeboard, located outside the LSS Office.

This year promises more great activities from the LSS and students are encouraged to actively participate.

Eligibility for Austudy

Austudy provides financial help to full-time students who meet its income and assets requirements. Application forms and information about Austudy eligibility are available from offices of the Student Services Unit at the City and Kuring-gai campuses. **Students who receive Austudy and decide to drop subjects during the semester need to be aware that to remain eligible for Austudy they must be enrolled in a minimum of 18 credit points or have a HECS liability for the semester of .375.** The only exceptions made are for students with disabilities that interfere with their studies, students who are single supporting parents, or those who have been directed by the University to reduce their study load. Student Welfare Officers in the Student Services Unit can assist students who wish to apply for exceptions on these grounds.

PRIZES AND SCHOLARSHIPS

An annual prize ceremony is held at the Faculty of Law each year in recognition of the academic achievements of students. The following is a list of prizes awarded for the LLB degree. These prizes may be awarded each semester if there is a candidate who reaches a level of academic achievement acceptable to the Faculty Board in Law.

Scholarships

There are presently two scholarships available for the LLB degree. These are the Phillips Fox Scholarship in Law, and the Tress Cocks and Maddox Scholarship in Law, tenable for one year only and awarded to an enrolled Law student. Information is available from the Faculty of Law.

Donor	Name of prize	Value
<i>The Dean's Special Prize</i>	Awarded for outstanding contribution and service to the Faculty of Law	\$200
<i>Freehill Hollingdale and Page Prize</i>	Best performance in Personal Property	\$250 and Certificate
<i>Gross Prize in Family Law</i>	Best performance in Family Law	\$100 and Certificate
<i>Gross Prize in Human Rights</i>	Best performance in Human Rights	\$100 and Certificate
<i>Karen Morton Memorial Prize¹</i>	Best performance in Industrial and Intellectual Property	\$100 and Certificate
<i>Abbott Tout Prize¹</i>	Best performance in Local Government	\$100 and Certificate
<i>Ebsworth and Ebsworth Prize¹</i>	Best performance in Law of Insurance	\$200 and Certificate
<i>Henningham and Ellis-Jones Prize¹</i>	Best performance in Administrative Law	\$250 and Certificate
<i>NSW Bar Association Prize¹</i>	Best performance in Public International Law	\$250 and Certificate
<i>Veronica Pike Prize¹</i>	Best performance by a female student in Law of Evidence	\$100 and Certificate
<i>Corrs Chambers Westgarth Prize¹</i>	Best performance in International Trade Law	\$250 and Certificate
<i>Harcourt Brace Prize¹</i>	Best performance in Business Law	\$500 and Certificate
<i>Law Society of NSW Prize</i>	Best performance in Real Property	\$100 and Certificate
<i>Butterworths Book Prizes</i>	These are offered as awards of academic merit to students within the first year of the course.	

The following prizes may be awarded to students enrolled in the LLM and SJD postgraduate programs.

Donor	Name of prize	Value
<i>CCH Book Prize for Taxation Law¹</i>	Highest mark in International Taxation	Book
<i>CCH Book Prize for Air Law</i>	Second highest mark in Air Law	Book
<i>Phillips Fox Prize for Air Law</i>	Highest mark in Air Law	\$200
<i>Phillips Fox Prize for Chinese Law¹</i>	Highest mark in a Chinese Law subject	\$250
<i>Davies Collison Cave Prize for Trade Marks Law¹</i>	Highest mark in Trade Marks Law	\$250
<i>NSW Bar Association Prize for Dispute Resolution¹</i>	Highest mark in Dispute Resolution	\$250
<i>UTS Alumni Association Achievement Award</i>	Awarded to a student (or students), undergraduate or postgraduate, for contribution to worthwhile campus, community, humanitarian or cultural activities that are to the benefit of, or bring credit to, the University.	\$500

¹ Prize awarded annually.

LIST OF COURSES AND CODES

Course title	Code
Doctor of Philosophy (PhD)	LL54
Doctor of Juridical Science (SJD)	LL53
Master of Laws (by thesis) (LLM)	LL51
Master of Laws (by coursework) (LLM)	LL52
Master of Comparative Law (MCL)	LL63
Master of Dispute Resolution (MDR)	LL59
Master of Legal Studies (MLS)	LL68
Master of Taxation Law (MTax)	LL58
Graduate Diploma in Australian Law (GradDipAustLaw)	LL57
Graduate Diploma in Corporate Law (GradDipCorpLaw)	LL62
Graduate Diploma in Law for Secondary Teachers (GradDipLaw)	LL64
Graduate Diploma in Legal Studies (GradDipLS)	LL67
Graduate Certificate in Continuing Legal Practice	LL71/LL73
Graduate Certificate in Dispute Resolution	LL69
Graduate Certificate in Comparative Law	LL56
Graduate Certificate in Corporate Law	LL61
Graduate Certificate in Law for Secondary Teachers	LL66
Graduate Certificate in Legal Practice	LL70/LL72
Bachelor of Laws (LLB) (F/T)	LL01
Bachelor of Laws (LLB) (P/T)	LL01
Bachelor of Laws in Australian Indigenous Law (LLB)	LL08
Double degrees	
Bachelor of Business/Bachelor of Laws (BBus LLB)	LL02
Bachelor of Science in Computing Science/Bachelor of Laws (BCompSc LLB)	LL06
Bachelor of Arts/Bachelor of Laws (BA LLB)	LL05
Bachelor of Arts in Communication (Journalism)/Bachelor of Laws (BA LLB)	LL10
Bachelor of Arts in Communication (Media Arts and Production)/ Bachelor of Laws (BA LLB)	LL11
Bachelor of Arts in Social Science/Bachelor of Laws (BA LLB)	LL12
Bachelor of Science/Bachelor of Laws (BSc LLB)	LL04
Bachelor of Medical Science/Bachelor of Laws (B Med Sc LLB)	LL09
Combined degrees	
Bachelor of Laws/Bachelor of Arts in International Studies (LLB BA)	LL07

Undergraduate courses

Course information and inquiries

Senior Administrative Officer
Mrs Philippa Williams
Telephone: 9514 3760

Administrative Assistant (Undergraduate)
Mr Michael Fenaughty
Telephone: 9514 3719

Administrative Assistant (Double degree and combined degree programs)
Ms Jennifer Donovan
Telephone: 9514 3748

Secretary (Undergraduate)
Miss Debbie Margaritis
Telephone: 9514 3731
Fax: 9514 3400

Academic advice may be obtained from the Director of Undergraduate Programs
Ms Ruth Davis
Telephone: 9514 3761

Electives

Law electives

In order to assist students to perceive the interrelationship of the various electives and their general orientation, and to make informed choices, the electives are classified into the groups indicated below.

Criminal Law: Administration of Criminal Justice, Human Rights, Criminology

Commercial Law: Industrial and Intellectual Property, Law and Computers, Advanced Taxation, Law of Insurance, Deceptive Trade Practices and Product Liability, Law and Society, Restrictive Trade Practices, Advanced Company Law, Transport Law – Selected Problems, Dispute Resolution, Advanced Contracts, Sale of Goods, Finance Law, Revenue Law, Insolvency

Environmental Law: Environmental Law, Local Government Law, Law and Natural Resources

Technology: Industrial and Intellectual Property, Law and Computers, Communications Law, Media Law, Biotechnology Law and Bioethics

International Law: Public International Law, Human Rights, Environmental Law, Transport Law – Selected Problems, International Trade Law, International Economic Law, Jessup International Moot, Conflict of Laws, Advanced Conflict of Laws

Private Law: Succession, Family Law, Children and the Law

Research: Research Project, Community Legal Research

Labour and Industrial Relations: Labour Law, Industrial Law, Social Security Law

Land Law: Strata Titles and Community Schemes, Environmental Law, Local Government Law, Land Dealings, Law and Natural Resources

Legal Theory and Perspective: Comparative Law, Human Rights, Jurisprudence, Law and Society, Women and the Law, Law and Medicine, Citizenship and Immigration Law, Advanced Constitutional Law, Advanced Administrative Law, Dispute Resolution, Indigenous Peoples and the Law

Non-Law electives

Students may study up to 24 credit points of non-Law electives. Students must obtain the permission of the Associate Dean (or nominee) if they wish to enrol in non-Law subjects offered by other faculties of the University or other universities.

In addition to seeking the approval of the Associate Dean, it is necessary to approach the faculty or institution in which the non-Law subjects are to be studied to obtain approval, and also to ensure that any prerequisites or corequisites are satisfied.

Among the non-Law electives available are those in Aboriginal Studies set out in the following list. Details may be obtained from the School of Adult Education.

015110	Aboriginal Cultures and Philosophies	8cp
015111	Issues in Aboriginal Education	8cp
015112	Aboriginal Initiatives in Education: Towards Community Control	8cp
015113	Teaching Aboriginal Studies	8cp
015114	Aboriginal Studies	4cp
015115	Introducing Aboriginal Cultures and Philosophies	6cp
54230	Aboriginal Social and Political History	8cp
54231	Aboriginal People and the Media	8cp
54330	The Politics of Aboriginal History	8cp
54331	Aboriginal Forms of Discourse	8cp

International Studies electives

The Institute for International Studies at UTS offers electives in language studies and in the study of contemporary societies in parts of the non-English-speaking world. All subjects are taught over one semester and have a value of eight credit points.

Language studies

All students wishing to take language studies as a credited part of their degree are required to enrol through the Institute for International Studies, whether the language studies are undertaken on a UTS campus or elsewhere. The Institute teaches some language programs at UTS, has made arrangements with other universities for some language programs to be taught to UTS students, and can make special arrangements for individual students to attend specific language programs where academic needs demand.

The individual student’s level of language proficiency before entry to the UTS program determines their level of language study. There

is a range of entry levels to the various programs available. Most are available at beginners’ and post-HSC levels, and some at more advanced levels.

The Institute offers language programs in Cantonese, Chinese, Croatian, French, German, Greek, Indonesian, Italian, Japanese, Korean, Malaysian, Polish, Russian, Slovenian, Spanish, Thai and Ukrainian. The Institute can arrange for the teaching of other language programs depending on availability and demand.

Contemporary Society

The Institute also offers a series of subjects that provide an introduction to the contemporary societies, politics, economics and culture of the countries of East Asia and South-East Asia, Latin America and Europe that are the areas of specialisation of the Institute.

Introductory subjects on the contemporary societies of China, Japan, South-East Asia, Hong Kong, Taiwan, Latin America and Europe are available. There are no prerequisites for any of the Contemporary Society subjects. All subjects are taught in English and are available, with permission of their faculties, to all UTS students.

Further information is available from the Institute for International Studies, UTS, 9-11 Broadway, telephone 9514 1574, fax 9514 1578 and the *Institute for International Studies Handbook*.

Subjects open to other faculties

Students enrolled in other faculties in the University may apply for approval to enrol in Law subjects. This approval is subject to the meeting of prerequisites and class sizes. Applications are to be made prior to enrolment to the Director of Undergraduate Programs of the Law Faculty (or his/her nominee).

Non-award students

Applications may be made by persons not enrolled in the University to enrol in Law subjects as non-award students. Applications should be directed to the Non-Award Studies Officer, Tower Building, Broadway.

Miscellaneous students

Law students who have completed the course may enrol as miscellaneous students in subjects they were not able to complete while enrolled. Applications should be directed to the Non-Award Studies Officer, Tower Building, Broadway.

The Summer program in Law

The Faculty offers a Summer program to enable enrolled Law students to undertake one or two electives at the conclusion of the Spring semester. The Summer program will consist of six teaching weeks in January and February and includes a weekend workshop.

Details of application procedures for the 1998/1999 Summer session will be placed on the Faculty notice board in September 1998.

Computer laboratory within the Faculty

Computers are available for student use at the Faculty of Law. Inquiries for booking the use of these machines should be directed to Andrew Mowbray, the Faculty's Law Computer Consultant.

Recommended reading prior to entry

A Guide to Legal Problem Solving for Law Students, P Keyzer, Butterworths, or *A Career in Law*, Federation Press, may be purchased from the Co-op Bookshop, the Sydney Law Cooperative Bookshop, Butterworths or the Law Book Company.

Graduate Employment and Summer Clerkship programs

Students wishing to apply to enter the programs must do so in their penultimate year of study. The Faculty of Law participates in the Graduate Employment and Summer Clerkship programs conducted by many of the law schools in NSW in conjunction with the major Sydney law firms and government departments. Many of the firms will only employ graduates through the programs.

The application closing date for the programs is normally set in May/June of each year, and interested students are advised to watch the noticeboards because the deadlines imposed are strictly adhered to. Ian Ellis-Jones is the Academic Coordinator to be contacted with regard to these programs.

Assessment

While assessment varies from subject to subject, students may be required to do one or more of the following: final examinations, informal examinations, take-home examinations, assignments, research work, class participation, moot, presentation of seminar papers or a *viva voce*.

Coordinating examiners will advise students of the mode of assessment for their subjects in their course outline and/or by notice on the noticeboard by the end of the third week of the semester.

Lodgement of assignments

Students are required to retain a copy of any assignment lodged in the assignment box.

Students who are handing in written work must submit it, with an assignment coversheet attached, in the assignment box located on Level 3 at the Law Faculty at Haymarket. The assignment box is cleared daily at 6.00 p.m. **Assignments submitted by DX or by fax will not be accepted by the Faculty.**

Formal requirements

Essays and other written work should be prepared in accordance with the guidelines laid down in the Faculty of Law's *Guide to Essay Writing*, which may be obtained from the Faculty.

All work submitted for assessment should bear an assignment coversheet. These are available from the Law Information Office.

If required by the lecturer concerned, the work must be typed.

The work must be properly written with due regard to spelling, punctuation, grammar and syntax.

Unless otherwise instructed by the lecturer concerned, all written work should include footnotes or endnotes and a bibliography in the manner set out in the *Guide to Essay Writing*.

Any piece of written work which does not comply with these requirements may be:

- required to be rewritten in proper form;
- penalised in marks; or
- rejected without assessment.

Late work

Any work submitted after the date for submission may be penalised in marks or rejected without assessment.

Plagiarism

Where individual work is required for the purposes of assessment, the copying, unacknowledged use of, or reliance on the work of other individuals without acknowledgment is considered to be cheating/misconduct. The penalties imposed for

cheating/misconduct or **allowing work to be plagiarised** are severe under the University rules and regulations.

Plagiarism is one of the most serious crimes in the academic community – it indicates an attempt by someone to pass off the words and/or ideas of another as their own. To take any but a few sequential words of another without acknowledgment is plagiarism and tantamount to cheating. It will be so treated in the Faculty of Law.

Experience shows that one of the most common ways for plagiarism to occur is when students work together. It is acknowledged by the academic staff that study groups are an efficient and beneficial method of learning – peer tuition is effective – but problems arise when it is extended into the assessment process. The Faculty expects, in fact demands, all assignments submitted to be the work of the person who is credited with the mark. It can be an extremely fine line between discussion of an essay topic with another and collaboration, but where comparisons of various students' work indicate collaboration, this will be taken to be plagiarism and the Faculty policy will be invoked. (Faculty of Law *Guide to Essay Writing* 1994, pp 22–23.)

Any acts of plagiarism will be penalised. Such penalties may include, depending upon the seriousness and nature of the offence:

- a requirement that the assignment be rewritten *de novo*;
- a penalty in the reduction of marks awarded to the work, which may include a reduction to zero, or a sharing of the mark awarded to the document among its apparent authors;
- a fail result in the subject concerned; and
- a referral of the matter to the Associate Dean or other appropriate body.

Progression and acceleration policy

The following policy will apply to progression and acceleration.

Students will be permitted to enrol in subjects totalling up to 28 credit points per semester with the leave of the Associate Dean or nominee, if:

- there is no timetable clash;
- prerequisites and corequisites are satisfied;
- class size ceilings are not exceeded;

- the student's academic record indicates he or she is capable of performing satisfactorily when accelerating; and
- the student can demonstrate that his or her work and other non-study commitments permit him or her to accelerate without detriment to his or her studies.

The Faculty of Law is unable to guarantee that there will be no timetable clash or no final examination clashes where students do not progress normally.

Exemptions

Subject to the approval of the Faculty Board in Law, it is possible for students to obtain exemptions for both Law and non-Law subjects.

Law subjects

Students may be able to obtain an exemption from a Law subject if they are able to satisfy the Faculty Board that a comparable course of study has been successfully undertaken as an LLB subject within the Law Faculty of another recognised university. As a general rule, exemptions will not be given if the subject was studied more than six years ago. The period in the 'six-year rule' shall be calculated from the date on which the subject in which the exemption is sought was successfully completed, to when it is due to be undertaken in the Faculty of Law. However, the Faculty Board shall always retain a discretion to waive the strict application of the rule in cases where there is additional evidence of work or study experience. Indeed, in subjects where there have been significant recent changes in the law, an exemption may not be granted even though the subject was successfully completed less than six years ago.

The Faculty Board must be satisfied that the student has successfully completed a comparable subject elsewhere. To verify this, the student must produce a transcript of his or her academic record and a copy of the relevant institution's handbook containing a detailed description of the subject, together with the reading guide that was current at the time of study.

Exemption for Law subjects will only be granted to students who have studied law in a recognised law school. Students who have studied law through the Law Extension Committee of the Supreme Court (LPAB) will not be granted exemptions.

Non-Law subjects

It is possible to obtain exemptions for non-Law electives in the LLB and LLB (Indigenous) programs if students have completed a degree, diploma or associate diploma course from a recognised tertiary institution.

The maximum exemptions that can be granted on the basis of having completed a course are as follows:

- a degree course (three years full time) – 48 credit points
- a diploma course (three years full time) – 36 credit points
- an associate diploma course (two years full time) – 24 credit points

Students wishing to study non-Law electives within their Law degree, in either other faculties of the University or within a degree course at another university, may be granted approval to undertake up to 48 credit points. Formal application to do so must be made in writing to the Faculty Board in Law.

Partially completed courses

No exemptions can be sought for a partially completed diploma or associate diploma course.

Students entering the LLB or LLB (Indigenous) programs with a partially completed degree, either as transfer students from another faculty of the University or from another university, may be granted up to a maximum of 24 credit points.

Students who wish to undertake subjects at another university and receive accreditation for them must apply in writing to the Faculty Board in Law.

Students who are seeking exemptions should complete an Application for Exemptions form, which is available from Administration. It is recommended that all students seeking an exemption should make an application early in the course. Inquiries should be directed to the Law Information Office.

Internal course transfers

UTS students who internally transfer into the LLB or LLB (Indigenous) programs may receive up to 48 credit points of exemptions from non-Law electives for subjects which have been completed as part of their previous UTS studies.

Honours

It will be possible for students to gain an award with Honours in the Law degrees or the Law component of combined or double degrees.

The LLB degree is awarded **with** Honours, and does not require an additional Honours year. To this end, the Research Project, which is a necessary requirement, must be undertaken as an elective subject of six credit points within the degree. **This subject forms part of the credit points required for degree completion**, 192 for the full-time or part-time degree, 144 for combined or double degrees.

Application to undertake a Research Project must be made at least one month prior to enrolling in the subject. Students should make an appointment to see the coordinator to discuss the procedure that must be followed. As a research project normally takes longer than a semester to complete, students are advised to enrol in the subject in their third last semester of study, particularly if they intend undertaking the legal practice major in their final semester, for no subjects may be undertaken in conjunction with this major.

The Honours Regulations are set out below:

1. **Awards**
 - 1.1 Awards of the Law degree or the Law component of a combined or double degree shall be classified as follows:
 - (a) degree (with First Class Honours);
 - (b) degree (with Second Class Honours); and
 - (c) degree
 - 1.2 Award of the degree with Second Class Honours shall not be graded.
2. **Requirements of Honours**
 - 2.1 To qualify for an award of the degree with Honours a student shall:
 - (a) successfully complete the subject 76040 Research Project 4;
 - (b) obtain an Honours mark, calculated in accordance with the formula 'Sum of All' (Law subject credit points x mark) divisible by the 'sum of all Law subject credit points' such that
 - (i) for First Class Honours – 75 per cent
 - (ii) for Second Class Honours – 65 per cent

- (c) not fail any subject after the first semester of study;
- (d) successfully complete not less than 96 credit points of Law subjects within the Faculty of Law;
- (e) for the purpose of the calculation in (b), students may discount up to six of their worst subjects provided that at least 12 UTSLLB subjects are included in the calculation; and
- (f) a student's Honours mark shall include the mark obtained by the student in the subject Research Project notwithstanding that such mark might be one of their worst subjects.

2.2 In exceptional circumstances the Faculty Board in Law may modify or dispense with the requirements of Regulation 2.1(c) and (d).

The University medal

The University may award a medal to students who have achieved outstanding academic merit throughout their undergraduate degree course. The medal awarded within the Bachelor of Laws program is to the student achieving the highest marks at First Class Honours level.

Regulations of the Faculty of Law

The following regulations relate to the Research Project and refer only to the Bachelor of Laws program in the Faculty of Law.

Research project regulations

1. The regulations apply to the following elective subject 76040 Research Project 4:
2. A student undertaking a research project is required to demonstrate:
 - (a) a high level of understanding of the law relevant to the topic;
 - (b) the capacity to research and analyse legal material;
 - (c) the ability to use research tools and skills; and
 - (d) the ability to present the results of the research in a coherent and comprehensive form.
3. A student shall not complete more than one research project.
4. Assessment is based on a dissertation to be submitted by students which will normally be expected to lie within the following range:
Research Project: 12,000–15,000 words.
5. Where research related to research projects has been done for another purpose either in the Faculty of Law or elsewhere, full disclosure of that prior research must be made at the time the topic is submitted for approval. If the topic is approved notwithstanding such prior research, then that research shall not form part of the work completed for the research project and shall be excluded from the final assessment. The student shall provide further information concerning that research as may be requested by the Supervisor, the examiners or the Subject Coordinator.
6. The examiners of research projects may require the student to undergo a *viva voce* examination, in which case the *viva voce* shall form part of the assessment of the subject.
7. The Faculty Board in Law has ultimate control over all aspects of research projects. Any student, the Subject Coordinator or the Associate Dean has the right to approach the Board on any issue arising out of these regulations, a research project or assessment.
8. There shall be a Subject Coordinator for research projects who shall be appointed at the first Faculty Board meeting in the Faculty of Law each year and shall hold office until the first Faculty Board meeting the following year. During the absence of the Subject Coordinator, the Director of Undergraduate Programs or Associate Dean may act in his or her stead.
9. A student may enrol in the subject Research Project only if that student has:
 - (a) successfully completed Stages 1–8 of the part-time program; and
 - (b) successfully completed any core subject or elective subject relevant to the topic.
10. A student wishing to undertake a research project shall submit a written proposal to the Subject Coordinator on the form available from the Law Information Office. The proposal shall include the name of the topic of the proposed research project and the name of the Supervisor and must be signed by the Supervisor. Copies of these

- proposals shall be circulated by the Subject Coordinator to all members of the full-time academic staff of the Faculty of Law and, if no objection to the application is received by the Subject Coordinator within seven days of such circulation, the Subject Coordinator may approve the application, including the topic and the Supervisor. **Approval must be granted before enrolment is allowed.**
11. If the Subject Coordinator does not approve the application it shall be submitted to the next meeting of the Faculty Board, which may approve the application on such terms as it thinks fit, or disapprove the application.
 12. A student is required to enrol in the Research Project subject no later than the beginning of the semester following that in which the Subject Coordinator or the Faculty Board approved the proposed research project.
 13. (a) Supervisors have the day-to-day control and supervision of research projects and students are required to meet with their supervisors regularly.
 - (b) Any amendments to the research project proposal may be approved by the Supervisor if the project remains within the same substantial area as previously approved. However, any substantial amendments to the student's approved proposal shall be proposed in writing to the Supervisor and Subject Coordinator. Copies of the proposed amendment shall be circulated by the Subject Coordinator to all members of the Faculty's full-time academic staff and if no objection to the application is received within seven days of such circulation, the amendment is deemed to be approved.
 14. A research project shall normally be taken over one semester and the dissertation shall be lodged with the Subject Coordinator not later than 5.00 p.m. on the Friday of the 15th week of the semester.

Upon the student's written request the Associate Dean may, after consultation with the student's Supervisor and the Subject Coordinator, grant the student an extension of time for the submission of the project which shall not exceed two weeks from the original date of submission. Students requiring additional time are advised to seek leave and re-enrol in the subject in the following Autumn or Spring semester.
 15. The dissertation must comply with the following format rules:
 - (a) Two copies of the dissertation shall be presented to the Subject Coordinator. One of these copies will be returned to the student after examination.
 - (b) The dissertation shall be written in English in good quality typescript on one side of the paper only. In the body of the dissertation, one-and-one-half spacing is preferred, but double-spacing is permissible. Single spacing may only be used for appendices, footnotes and quotations.
 - (c) The paper used shall be good quality medium weight white stock, sufficiently opaque for normal reading.
 - (d) The size of the paper shall be ISO A4 (297 mm x 210 mm).
 - (e) The margins on each sheet shall be not less than 40 mm on the left-hand side, and 20 mm on the right-hand side, top and bottom.
 - (f) Both copies of the dissertation shall be accompanied by an abstract of not more than 400 words.
 - (g) Both copies of the dissertation shall be presented in a permanent and legible form and if not bound, then suitable for future binding.
 - (h) Each copy of the dissertation shall be enclosed in a stiff cover.
 16. For the research project, there shall be two examiners, appointed by the Faculty Board. If there are any unresolved differences of opinion on any matter relevant to a student's assessment such differences shall be resolved by an umpire appointed by the Associate Dean.
 17. Prior to final assessment of a research project the examiners may require the student to rewrite and resubmit the dissertation in whole or in part and in such a case the examiners shall provide details of the parts of the dissertation that require amendment, and their reasons for requiring such amendment. When a student is required to rewrite and resubmit the dissertation that student shall be permitted to extend the subject over two semesters and shall re-enrol in the subject for a second semester.

Bachelor of Laws

Course code: LL01

The objective of the Bachelor of Laws course is to enable students to reach a stage of creativity at which they have sufficient knowledge and sufficient ability to seek their own solutions to legal problems – solutions which they can justify in legal terms by using the legal materials at their disposal in a professional way.

Australia has a highly complex legal system and, as society has developed, so has the role of the lawyer. The range of knowledge and skills which lawyers now require is extensive. Today's lawyers are increasingly called upon to act as negotiators to settle matters, and to advise and counsel parties. The function of the lawyer also includes foreseeing problems and preventing the incident of disputation, as well as resolving disputes when they cannot be avoided. The course is concerned with the total range of functions of lawyers in the community. A preventive emphasis will also be apparent in the teaching of the various subjects throughout the course. Consideration will be given to how people can organise their affairs so as to anticipate and avoid potential disputes. In this regard, consideration will be given to the application of more than one and sometimes conflicting rules to a particular set of facts.

The primary object is not to produce specialists in any particular field of law. Although a degree of specialisation is allowed for in the provision of elective subjects, the view taken is that specialisation is something which comes later. The aim of the Law course is to provide a basis upon which subsequent specialisation can be built.

The subjects have been selected on the basis of two criteria: to provide (a) an overview of the legal system as a whole, and (b) an opportunity for the student to practise legal skills in differing contexts. The subjects are introductions, not to the law as a whole, but to the relevant branch of the law. They are designed to provide an understanding of the conceptual framework involved, the development of these concepts and a consideration of areas of current controversy. It is in the last area that the opportunity will be provided for students to develop their skill in the handling of legal material and thus reach the stage of independent legal creativity.

Course structure

The duration of the LLB course is four years in the full-time attendance mode and six years in the part-time attendance mode. The course is arranged in stages on a semester basis.

The Autumn semester normally commences in early March and the Spring semester commences in early August.

The overall structure has two components – the core and elective subjects, which include an optional legal practice major.

(a) Core subjects (96 credit points)

The core of 14 subjects satisfies the Priestley requirements. The new core is as follows:

70113	Legal Process and History	10cp
70105	Legal Research	4cp
70217	Criminal Law	6cp
70211	Law of Contract	8cp
70311	Law of Tort	8cp
70616	Federal Constitutional Law	8cp
70317	Real Property	8cp
70318	Personal Property	4cp
70617	Administrative Law	8cp
70417	Corporate Law	8cp
70516	Equity and Trusts	8cp
71116	Remedies	6cp
71216	Law of Evidence	6cp
71005	Practice and Procedure	4cp

(b) Elective subjects (up to 96 credit points)

Depending upon their course of study, students must take up to 96 credit points of elective subjects. It is anticipated that for most students this will include the 24 credit points of the legal practice major.

From time to time, the Faculty Board will consider new electives devised to meet emerging legal developments or fresh areas of study.

Resources permitting, an array of electives will be made available (all of six-credit-point value) drawn from the following list:

76004	Administration of Criminal Justice
76061	Advanced Administrative Law
76028	Advanced Company Law
76059	Advanced Conflict of Laws
76060	Advanced Constitutional Law
76047	Advanced Contracts
76037	Advanced Criminal Law
76044	Advanced Family Law
76054	Advanced Public Law
76016	Advanced Taxation Law
76070	Biomedical Law and Bioethics
76066	Children and the Law

76048	Citizenship and Immigration Law
76042	Communications Law
76069	Community Legal Research
76001	Comparative Law A
76003	Comparative Law B
76112	Conflict of Laws ¹
76012	Criminology
76023	Deceptive Trade Practices and Product Liability
76052	Dispute Resolution ¹
76024	Environmental Law
76516	Family Law ¹
76065	Finance Law
76007	Human Rights
76068	Indigenous Peoples and the Law
76011	Industrial and Intellectual Property
76053	Industrial Law
76115	Insolvency ¹
76018	International Economic Law
76051	International Trade Law
76039	Jessup International Moot
76008	Jurisprudence
76015	Labour Law
76029	Land Dealings
76014	Law and Computers
76045	Law and Medicine
76064	Law and Natural Resources
76022	Law of Insurance
75404	Legal Accounting and Professional Responsibility
76026	Local Government Law
76063	Media Law
76900	Moot ¹
76006	Public International Law
76027	Restrictive Trade Practices
76212	Revenue Law ¹
76411	Sale of Goods ¹
76062	Social Security Law
76017	Strata Titles and Community Schemes
76517	Succession ¹
76049	Transport Law – Selected Problems
76046	Women and the Law

¹ These electives are recommended if the student intends to practise as a solicitor or barrister, or undertake the PLT major.

(c) Legal practice major (24 credit points)

The legal practice major integrates a course of Practical Legal Training into the undergraduate law degree. It is an option which may be taken by students in their final semester of study, in place of four elective Law subjects (24cp). It is the equivalent of Stage 1 of the Law Society of NSW's Professional Program which is conducted by the College of Law. It comprises five subjects and is taught over 15 weeks from 9.00 a.m. – 5.00 p.m.

Mondays to Fridays. These same subjects will be taught to Law graduates who wish to complete the Graduate Certificate in Legal Practice offered by the postgraduate area of the Faculty of Law. Undergraduate students may elect to study the first five legal practice subjects contained within the new Graduate Certificate in Legal Practice. A student who completes them as part of the undergraduate degree program will receive advanced standing in the new Graduate Certificate in Continuing Legal Practice. In the undergraduate context, this group of five subjects forms the optional legal practice major (Practical Legal Training – PLT) of 24 credit points:

75400	Legal Skills and Advocacy	6cp
75401	Litigation	4cp
75402	Property Transactions	4cp
75403	Commercial and Estate Practice	4cp
75404	Legal Accounting and Professional Responsibility	6cp

The major is now offered in part-time as well as full-time mode, subjects being offered over three semesters of study.

No other subject may be taken in conjunction, and students in double degrees must have completed 48 credit points of their studies in the other degree prior to enrolling in the legal practice major.

(d) Non-Law electives

Because of program constraints, double and combined degree students will not be able to undertake non-Law electives.

Law students who have not sought exemptions on the basis of a prior degree may study up to 48 credit points of non-Law electives. Students will be required to obtain the permission of the Associate Dean (or nominee) if they wish to enrol in non-Law subjects offered by other faculties of the University or other universities.

In addition to seeking the approval of the Associate Dean, it will be necessary to approach the faculty or institution in which the non-Law subjects are to be studied to obtain approval, and also to ensure that any local prerequisite or corequisite requirements are satisfied.

Course structure

Full-time attendance mode

The course structure is as follows. Credit-point values are shown. Timetable constraints may require attendance at daytime and evening classes.

Stage 1

70113	Legal Process and History	10cp
70217	Criminal Law	6cp
70105	Legal Research	4cp

Stage 2

70211	Law of Contract	8cp
70311	Law of Tort	8cp
70616	Federal Constitutional Law	8cp

Stage 3

70318	Personal Property	4cp
70317	Real Property	8cp
76xxx	Elective subject 1	6cp
76xxx	Elective subject 2	6cp

Stage 4

70617	Administrative Law	8cp
70417	Corporate Law	8cp
76xxx	Elective subject 3	6cp
76xxx	Elective subject 4	6cp

Stage 5

70516	Equity and Trusts	8cp
76xxx	Elective subject 5	6cp
76xxx	Elective subject 6	6cp
76xxx	Elective subject 7	6cp

Stage 6

71216	Law of Evidence	6cp
71005	Practice and Procedure	4cp
71116	Remedies	6cp
76xxx	Elective subject 8	6cp

Stage 7

76xxx	Elective subject 9	6cp
76xxx	Elective subject 10	6cp
76xxx	Elective subject 11	6cp
76xxx	Elective subject 12	6cp

Stage 8

Legal practice major (PLT)	24cp
<i>or</i>	
Four Law electives	24cp

Part-time attendance mode

Timetable constraints may require attendance at daytime and evening classes. The course structure is as follows.

Stage 1

70113	Legal Process and History	10cp
70105	Legal Research	4cp

Stage 2

70217	Criminal Law	6cp
70211	Law of Contract	8cp

Stage 3

70311	Law of Tort	8cp
70616	Federal Constitutional Law	8cp

Stage 4

70317	Real Property	8cp
70318	Personal Property	4cp

Stage 5

70417	Corporate Law	8cp
70617	Administrative Law	8cp

Stage 6

70516	Equity and Trusts	8cp
76xxx	Elective subject 1	6cp

Stage 7

71005	Practice and Procedure	4cp
71216	Law of Evidence	6cp
71116	Remedies	6cp

Stage 8

76xxx	Elective subject 2	6cp
76xxx	Elective subject 3	6cp
76xxx	Elective subject 4	6cp

Stage 9

76xxx	Elective subject 5	6cp
76xxx	Elective subject 6	6cp
76xxx	Elective subject 7	6cp

Stage 10

76xxx	Elective subject 8	6cp
76xxx	Elective subject 9	6cp
76xxx	Elective subject 10	6cp

Stage 11

76xxx	Elective subject 11	6cp
76xxx	Elective subject 12	6cp

Stage 12

Legal practice major (PLT)	24cp
<i>or</i>	
Four Law electives	24cp

Bachelor of Laws in Australian Indigenous Law

Course code: LL08

This degree offers students the opportunity to gain a qualification tailored to the needs of Aboriginal and Torres Strait Islander communities, and which satisfies the academic requirements of the Supreme Court of NSW for admission as a legal practitioner.

The program will allow students the option of undertaking a Practical Legal Training (legal practice) major as part of their undergraduate studies. Subsequently, graduates will be able to proceed, subject to the availability of places, into the Graduate Certificate in Continuing Legal Practice to complete the remaining component of the PLT requirements.

Alternatively, students may choose to complete their undergraduate degree from the choice of electives and delay PLT studies for up to two years, or even forego such studies completely. Applicants and students who decide on this latter course must realise that, under the current rules of the Legal Practitioners Admission (LPA) Board, upon graduation they will not be able to practise as a solicitor or barrister in NSW unless they are able to demonstrate substantial legal experience to the satisfaction of the LPA Board.

Course structure

The full-time LLB/Indigenous LLB normally requires four years for completion and the part-time LLB six years. All subjects are taught over one semester. Full-time students attend 10 to 14.5 hours of lectures per week and part-time students attend classes from seven to nine-and-a-half hours per week. Part-time students will normally be required to attend classes half a day and two evenings per week and full-time students may be required to attend evening classes. The LLB/Indigenous LLB is available at both Pass and Honours level and includes and optional major in Legal Practice. Students who have already completed a degree in another discipline may apply for exemption from 24 credit points of non-Law electives. Students who do not apply for these exemptions may take up to 24 credit points of non-Law electives in other faculties.

The compulsory subjects in the Australian Indigenous Law component are:

- Family Law and Women's Perspectives – Aboriginal and Torres Strait Islander People;
- Criminal and Civil Law – Indigenous Perspectives;
- Australian Indigenous Customary Law incorporating Indigenous Land Issues;
- Current Law Reform Proposals – Indigenous Perspectives;
- International Law and Treaty Obligations, State and Regional Protocols – Indigenous Peoples; and
- Indigenous Dispute Resolution.

LLB/Indigenous LLB students may also study up to 48 credit points of non-Law electives in other faculties. The following examples are available in the Faculty of Education:

015110	Aboriginal Cultures and Philosophies	8cp
015111	Issues in Aboriginal Education	8cp
015112	Aboriginal Initiatives in Education: Towards Community Control	8cp
015113	Teaching Aboriginal Studies	8cp
015114	Aboriginal Studies	4cp
015115	Introducing Aboriginal Cultures and Philosophies	6cp

HSCTER and UAC Course Code

This course was offered for the first time in 1997 by direct application. The UAC course code for the full-time LLB/Indigenous LLB is 604010 and for the part-time LLB it is 604011.

Assumed Knowledge

An adequate proficiency in English is assumed.

Course program – full-time

Year 1

Stage 1

70113	Legal Process and History	10cp
70105	Legal Research	4cp
70217	Criminal Law	6cp

Stage 2

70211	Law of Contract	8cp
70311	Law of Tort	8cp
70616	Federal Constitutional Law	8cp

Year 2

Stage 3

70317	Real Property	8cp
70318	Personal Property	4cp

76702	Criminal and Civil Law – Indigenous Perspectives	6cp
76xxx	Elective subject 1	6cp

Stage 4

70417	Corporate Law	8cp
70617	Administrative Law	8cp
76703	Australian Indigenous Customary Law – Incorporating Indigenous Land Issues	6cp
76xxx	Elective subject 2	6cp

Year 3

Stage 5

70516	Equity and Trusts	8cp
76701	Family Law and Women’s Perspectives – Aboriginal and Torres Strait Islander People	6cp
76xxx	Elective subject 3	6cp
76xxx	Elective subject 4	6cp

Stage 6

71216	Law of Evidence	6cp
71005	Practice and Procedure	4cp
71116	Remedies	6cp
76704	Current Law Reform Proposals – Indigenous Perspectives	6cp

Year 4

Stage 7

76xxx	Elective subject 5	6cp
76xxx	Elective subject 6	6cp
76705	International Law and Treaty Obligations, State and Regional Protocols – Indigenous Peoples	6cp
76706	Indigenous Dispute Resolution	6cp

Stage 8

Legal practice major (PLT)	24cp
<i>or</i>	
Four Law electives	24cp

Course program – part-time

Year 1

Stage 1

70113	Legal Process and History	10cp
70105	Legal Research	4cp

Stage 2

70211	Law of Contract	8cp
70217	Criminal Law	6cp

Year 2

Stage 3

70311	Law of Tort	8cp
70616	Federal Constitutional Law	8cp

Stage 4

70317	Real Property	8cp
70318	Personal Property	4cp

Year 3

Stage 5

70417	Corporate Law	8cp
70617	Administrative Law	8cp

Stage 6

70516	Equity and Trusts	8cp
76702	Criminal and Civil Law – Indigenous Perspectives	6cp

Year 4

Stage 7

71005	Practice and Procedure	4cp
71216	Law of Evidence	6cp
71116	Remedies	6cp

Stage 8

76703	Australian Indigenous Customary Law – incorporating Indigenous Land Issues	6cp
76xxx	Elective subject 1	6cp
76xxx	Elective subject 2	6cp

Year 5

Stage 9

76701	Family Law and Women’s Perspectives – Aboriginal and Torres Strait Islander People	6cp
76xxx	Elective subject 3	6cp
76xxx	Elective subject 4	6cp

Stage 10

76704	Current Law Reform Proposals Indigenous Perspectives	6cp
76xxx	Elective subject 5	6cp
76xxx	Elective subject 6	6cp

Year 6

Stage 11

76705	International Law and Treaty Obligations, State and Regional Protocols – Indigenous Peoples	6cp
76706	Indigenous Dispute Resolution	6cp

Stage 12

Legal practice major (PLT)	24cp
<i>or</i>	
Four Law electives	24cp

DOUBLE DEGREES

Bachelor of Business/ Bachelor of Laws

Course code: LL02

This double degree (two testamurs) is of five years' duration and students undertake studies full time with classes held during the day and evening. The program will allow students the option of undertaking a Practical Legal Training (legal practice) major as part of their undergraduate studies. Subsequently, graduates will be able to proceed, subject to the availability of places, into the Graduate Certificate in Continuing Legal Practice to complete the remaining component of the PLT requirements.

Alternatively, students may choose to complete their undergraduate degree from the choice of electives and delay PLT studies for up to two years, or even to forego such studies completely. Applicants and students who decide on this latter course must realise that, under the current rules of the Legal Practitioners Admission (LPA) Board, upon graduation they will not be able to practise as a solicitor or barrister in NSW unless they are able to demonstrate substantial legal experience to the satisfaction of the LPA Board.

The Chartered Institute of Company Secretaries in Australia is the professional association for 9,500 company secretaries and other corporate managers in Australia. It is also the Australian Division of the International Institute of Chartered Secretaries and Administrators to which its Australian members also belong.

Special arrangements exist between the University and the Institute under which Bachelor of Business/Bachelor of Laws students who have passed the University's examinations in four prescribed units can satisfy the Institute's full academic membership requirements without the need to sit the Institute's two qualifying examinations. During the course of their studies, students are encouraged to become student members of the Institute.

For details of the prescribed subjects and student membership, contact Michael Adams on 9514 5418. Alternatively, contact Dr John Nelson, National Education Manager, Chartered Institute of Company Secretaries, GPO Box 1594, Sydney, NSW 2001, or telephone toll free on 1800 251 849.

Course program

Year 1

Stage 1

79202	Business Law	4cp
25110	Microeconomics	4cp
22105	Accounting A	4cp
21125	International Business Environment	4cp
26122	Quantative Methods of Business	4cp
25308	Financial Markets	4cp

Stage 2

70113	Legal Process and History	10cp
70105	Legal Research	4cp
22205	Accounting B	4cp
25314	Business Finance	4cp

Year 2

Stage 3

70217	Criminal Law	6cp
70211	Law of Contract	8cp
25209	Macroeconomics	4cp
21130	Management and Organisations	4cp
24105	Marketing Principles	4cp

Stage 4

70311	Law of Tort	8cp
70616	Federal Constitutional Law	8cp
2xxxx	Business major 1	6cp

Year 3

Stage 5

70317	Real Property	8cp
70318	Personal Property	4cp
2xxxx	Business major 2	6cp
2xxxx	Business major 3	6cp

Stage 6

70617	Administrative Law	8cp
76xxx	Law elective 1	6cp
76xxx	Law elective 2	6cp
2xxxx	Business major 4	6cp

Year 4

Stage 7

70417	Corporate Law	8cp
70516	Equity and Trusts	8cp
71005	Practice and Procedure	4cp
2xxxx	Business major 5	6cp

Stage 8

71216	Law of Evidence	6cp
71116	Remedies	6cp
76xxx	Law elective 3	6cp
2xxxx	Business major 6	6cp

Year 5

Stage 9

21609	Business Strategy	4cp
2xxxx	Business major 7	6cp
2xxxx	Business major 8	6cp
76xxx	Law elective 4	6cp

Stage 10

	Legal practice major (PLT)	24cp
	<i>or</i>	
	Four Law electives	24cp

Bachelor of Business majors

- Accounting
- Banking
- Economics
- Finance
- International Business
- Management
- Marketing
- Tourism

The subject 76212 Revenue Law must be taken in the Accounting concentration.

**Bachelor of Science in Computing Science/
Bachelor of Laws**

Course code: LL06

This double degree (two testamurs) is of five years' duration and students undertake studies full time with classes held during the day and evening. The program will allow students the option of undertaking a Practical Legal Training (legal practice) major as part of their undergraduate studies. Subsequently, graduates will be able to proceed, subject to the availability of places, into the Graduate Certificate in Continuing Legal Practice to complete the remaining component of the PLT requirements.

Alternatively, students may choose to complete their undergraduate degree from the choice of electives and delay PLT studies for up to two years, or even to forego such studies completely. Applicants and students who decide on this latter course must realise that, under the current rules of the Legal Practitioners Admission (LPA) Board, upon graduation they will not be able to practise as a solicitor or barrister in NSW unless they are able to demonstrate substantial legal experience to the satisfaction of the LPA Board.

An important component within the Bachelor of Computing Science involves industrial experience over one semester – Computing Science staff will assist and advise students in obtaining suitable placements.

Course program

Stage 1

70113	Legal Process and History	10cp
70105	Legal Research	4cp
31415	Principles of Software Development A	6cp
31417	Computing Practice	6cp

Stage 2

70217	Criminal Law	6cp
70211	Law of Contract	8cp
31425	Principles of Software Development B	6cp
31429	Procedural Programming	6cp

Stage 3

70311	Law of Tort	8cp
70616	Federal Constitutional Law	8cp
31414	Information Systems	6cp
31416	Computer Systems Architecture	6cp

Stage 4

70318	Personal Property	4cp
70317	Real Property	8cp
31424	Systems Modelling	6cp
31428	Quantitative Modelling	6cp

Stage 5

70617	Administrative Law	8cp
70417	Corporate Law	8cp
31436	Systems Software and Networks	8cp
31434	Database Design	6cp

Stage 6

70516	Equity and Trusts	8cp
76xxx	Elective subject 1	6cp
31444	Systems Design and Development	10cp

Stage 7

71216	Law of Evidence	6cp
71005	Practice and Procedure	4cp
76xxx	Elective subject 2	6cp
76xxx	Elective subject 3	6cp
31455	Software Development Case Study ¹	5cp

Stage 8

71116	Remedies	6cp
76xxx	Elective subject 4	6cp
31455	Software Development Case Study (cont.) ¹	5cp
31464	Information Technology Planning and Design ¹	6cp

Stage 9

31454	Project Management and the Professional Industrial experience	8cp
-------	---	-----

Stage 10

	Legal practice major (PLT)	24cp
	<i>or</i>	
	Four Law electives	24cp

¹ These subjects may be replaced by Computing Science electives, with the approval of the Head of the School of Computing Sciences.

Bachelor of Arts/ Bachelor of Laws¹

Course code: LL05

This course is no longer offered to new students.

This course is of five years' duration (full time) and satisfies the academic requirements of the Supreme Court of NSW for admission purposes. The program will allow students the option to undertake a Practical Legal Training (legal practice) major as part of their undergraduate studies. Subsequently, graduates will be able to proceed, subject to availability of places, into the Graduate Certificate in Continuing Legal Practice to complete the remaining component of the Practical Legal Training (PLT) requirements.

Alternatively, students may choose to delay PLT studies for up to two years, or even to forego such studies completely. Students who decide on this latter course must realise that, under the current rules of the Legal Practitioners Admission (LPA) Board, they will not be able to practise as legal practitioners in NSW unless they are able to demonstrate substantial legal experience to the satisfaction of the LPA Board.

Students are enrolled in the Faculty of Law and are required to complete 240 credit points: 96 credit points in Arts and 144 credit points in Law. They will be awarded two degrees and the Law degree may be awarded with Honours.

¹ During 1997, the Faculty of Humanities and Social Sciences agreed to the award of two separate testamurs for the Bachelor of Arts/Bachelor of Laws currently studied at UTS to be offered from 1998.

To qualify for the Bachelor of Arts award, students currently enrolled in the degree course are required to complete 96 credit points of approved subjects offered by the Faculty of Humanities and Social Sciences.

Course structure

The course consists of 10 stages, each of one semester's duration.

The sequence for the Law subjects is based on a core curriculum, which students are required to study in the sequence indicated below. The Arts component provides choices for students at all stages and will be studied in the sequences established by those student choices. Students will be required to build their own program of Arts studies within the following parameters:

1. Students must take at least 22 credit points in foundation studies, 48 credit points in a major study and up to 26 credit points in other studies (with up to 12 credit points available from faculties other than Humanities and Social Sciences and Law if desired).
2. Approximately 24 credit points should be attempted each semester.
3. Foundation studies should be taken at the start of the course, and completed by the end of Stage 3 or no later than the end of Stage 4.
4. Students should commence the major at the earliest possible time in the course, that is, Stage 2 or 3, after completion of foundation studies subjects which are prerequisites for the various majors.

Foundation studies

Students will take at least 24 credit points with at least six credit points from each of the three groups of subjects below by the end of the third semester. The aim of the foundation studies is to introduce a range of ideas and intellectual approaches from the broadly defined arts/social sciences as a basis for: (i) exploration of issues of social concern and public interest; (ii) development of intellectual skills; and (iii) choice of areas to study in-depth.

Group A

52107	History of Ideas	8cp
52108	Politics and Political Institutions	8cp
52109	Culture, History and Society	8cp
52111	Contemporary Australia	6cp

Group B

55860	Information Science 1: Foundations of Information Science	6cp
56955	Communication 1	6cp
55864	Psychology	6cp

Group C

54100	Word and Text	6cp
54101	Sound and Image	6cp
54103	Communication Environments	6cp

Major study

A major is a sequence of subjects to a total of at least 48 credit points, which falls within a distinct and well-defined field of study. Several of the majors are interdisciplinary.

A major requires students to complete a minimum of 6 credit points and a maximum of 12 credit points at 100 Level; a minimum of 12 credit points at 200 Level; and a minimum of 12 credit points at 300 Level.

Entry to 200 Level subjects requires completion of prerequisites at 100 Level; entry to 300 Level subjects requires completion of 200 Level subjects and so on.

The majors offered in the Bachelor of Arts are:

- Aboriginal Studies
- Social, Political and Historical Studies
- Multicultural Studies
- Communication and Cultural Industries
- Information
- Communication
- Cultural Studies

Full details of the Arts majors and electives are contained in the *Faculty of Humanities and Social Sciences Handbook*.

Typical full-time program

Year 1

Stage 1 – Autumn

70113	Legal Process and History	10cp
70105	Legal Research	4cp
5xxxx	Arts Foundation Studies subject from A, B or C	6–8cp
5xxxx	Arts Foundation Studies subject from A, B or C	6–8cp

Stage 2 – Spring

70211	Law of Contract	8cp
70217	Criminal Law	6cp
5xxxx	Arts Foundation Studies subject from A, B or C	6–8cp
5xxxx	Arts Foundation Studies subject from A, B or C	6cp

Year 2

Stage 3 – Autumn

70311	Law of Tort	8cp
70616	Federal Constitutional Law	8cp
5xxxx	Arts major subject at 100 Level	6–8cp

Stage 4 – Spring

70317	Real Property	8cp
70318	Personal Property	4cp
5xxxx	Arts major subject at 200 Level	8cp
5xxxx	Arts major subject at 200 Level	8cp

Year 3

Stage 5 – Autumn

70417	Corporate Law	8cp
70617	Administrative Law	8cp
5xxxx	Arts major subject at 200 or 300 Level	8cp
5xxxx	Arts major subject at 300 Level	8cp

Stage 6 – Spring

70516	Equity and Trusts	8cp
76xxx	Elective subject 1	6cp
76xxx	Elective subject 2	6cp
5xxxx	Arts major subject at 300 Level	8cp

Year 4

Stage 7 – Autumn

71005	Practice and Procedure	4cp
71216	Law of Evidence	6cp
5xxxx	Other Arts studies/elective	8cp

Stage 8 – Spring

71116	Remedies	6cp
76xxx	Elective subject 3	6cp
5xxxx	Other Arts studies/elective	8cp

Year 5

Stage 9 – Autumn

76xxx	Elective subject 4	6cp
5xxxx	Other Arts studies/elective	8cp

Stage 10 – Spring

	Legal practice major (PLT)	24cp
	<i>or</i>	
	Four Law electives	24cp

Bachelor of Science/ Bachelor of Laws

Course code: LL04

This double degree (two testamurs) is of five years duration and students undertake studies full time with classes held in the day or evening.

Course structure

All subjects are taught over one semester. Students attend approximately 17 hours of lectures and seminars per week. Students may be required to attend evening classes. The degree requires five years' full-time attendance for completion. The LLB component is available at both Pass and Honours levels and includes an optional major in legal practice.

It is intended that there be a substantial degree of flexibility in the way in which students can progress through the course, although they will normally be expected to study science subjects and law subjects concurrently so that the two streams of study can better complement each other.

The following is a typical full-time course program.

Course Program

Stage 1		
70113	Legal Process and History	10cp
70105	Legal Research	4cp
xxxxx	Approved Science subjects	12cp
Stage 2		
70217	Criminal Law	6cp
70211	Law of Contract	8cp
xxxxx	Approved Science subjects	12cp
Stage 3		
70311	Law of Tort	8cp
70616	Federal Constitutional Law	8cp
xxxxx	Approved Science subjects	6cp
Stage 4		
70318	Personal Property	4cp
70317	Real Property	8cp
xxxxx	Approved Science subjects	12cp
Stage 5		
70417	Corporate Law	8cp
70617	Administrative Law	8cp
xxxxx	Approved Science subjects	6cp

Stage 6		
70516	Equity and Trusts	8cp
76xxx	Elective subject 1	6cp
xxxxx	Approved Science subjects	12cp
Stage 7		
71216	Law of Evidence	6cp
71005	Practice and Procedure	4cp
xxxxx	Approved Science subjects	12cp
Stage 8		
71116	Remedies	6cp
76xxx	Elective subject 2	6cp
xxxxx	Approved Science subjects	12cp
Stage 9		
76xxx	Elective subject 3	6cp
76xxx	Elective subject 4	6cp
xxxxx	Approved Science subjects	12cp
Stage 10		
	Legal practice major (PLT)	24cp
	<i>or</i>	
	Four Law electives	24cp

Bachelor of Medical Science/Bachelor of Laws

Course code: LL09

This double degree (two testamurs) will be offered for the first time in 1998. It is of five years duration and students undertake studies full time with classes held in the day or evening. It will enable students to obtain a professional qualification that satisfies the basic academic requirements of the Supreme Court of NSW for admission as a legal practitioner. The program will also produce graduates with a strong scientific background in human biology, behavioural science, neuroscience, pharmacology and diagnostics.

Course program

Year 1		
Stage 1		
70113	Legal Process and History	10cp
70105	Legal Research	4cp
91701	Medical Science 1	6cp
75101	Chemistry 1C	6cp
Stage 2		
70217	Criminal Law	6cp
70211	Law of Contract	8cp
91702	Medical Science 2	6cp
65201	Chemistry 2C	6cp

Year 2

Stage 3

70311	Law of Tort	8cp
70616	Federal Constitutional Law	8cp
68101	Physics 1C	6cp

Stage 4

70318	Personal Property	4cp
70317	Real Property	8cp
91704	Behavioural Sciences	6cp
68201	Physics 2C	6cp

Year 3

Stage 5

70417	Corporate Law	8cp
70617	Administrative Law	8cp
91313	Biochemistry 1	6cp
91703	Physiological Systems	6cp

Stage 6

70516	Equity and Trusts	8cp
76xxx	Elective subject 1	6cp
91708	Psychophysiology	8cp

Year 4

Stage 7

71216	Law of Evidence	6cp
71005	Practice and Procedure	4cp
91707	Pharmacology 1	8cp
xxxxx	Approved Science elective	4cp

Stage 8

71116	Remedies	6cp
76xxx	Elective subject 2	6cp
91709	Pharmacology 2	8cp
91705	Medical Devices and Diagnostics	6cp

Year 5

Stage 9

76xxx	Elective subject 3	6cp
76xxx	Elective subject 4	6cp
91706	Neuroscience	8cp

Stage 10

	Legal practice major (PLT)	24cp
	<i>or</i>	
	Four Law electives	24cp

NEW DOUBLE DEGREES

The Bachelor of Arts/Bachelor of Laws has been replaced by three new degrees:

Bachelor of Arts in Communication (Journalism)/Bachelor of Laws

Bachelor of Arts in Communication (Media, Arts and Production)/Bachelor of Laws

Bachelor of Arts in Social Science/Bachelor of Laws

These courses were designed to enable students to study Law and an area of professional practice in Humanities and Social Sciences.

All courses are of five years' duration (full time) and require attendance of approximately 17 hours of lectures and seminars per week. Students may be required to attend evening classes.

The Bachelor of Laws component is available at both Pass and Honours levels and includes an optional major in legal practice.

Bachelor of Arts in Communication (Journalism)/ Bachelor of Laws

Course code: LL10

This course enables students to adapt their professional skills to future social and technological change across a range of media.

Year 1

Stage 1

50114	Journalism 1	6cp
50109	Power and Change in Australia	6cp
50107	Contemporary Cultures 1	6cp
50105	Communication and Information Environments	6cp

Stage 2

70113	Legal Process and History	10cp
70105	Legal Research	4cp
50106	Media, Information and Society	6cp
50115	Journalism 2	6cp

Year 2**Stage 3**

70217	Criminal Law	6cp
70211	Law of Contract	8cp
50xxx	Journalism Strand subject (200 level)	8cp

Stage 4

70311	Law of Tort	8cp
70616	Federal Constitutional Law	8cp
50128	Media, Information and the Law	8cp

Year 3**Stage 5**

70318	Personal Property	4cp
70317	Real Property	8cp
76xxx	Law elective 1	6cp
50129	News and Current Affairs	8cp

Stage 6

70417	Corporate Law	8cp
70617	Administrative Law	8cp
50xxx	Journalism Strand subject (200 level)	8cp

Year 4**Stage 7**

70516	Equity and Trusts	8cp
71005	Practice and Procedure	4cp
76xxx	Law elective 2	6cp
50xxx	Journalism Strand subject (300 level)	8cp

Stage 8

71216	Law of Evidence	6cp
71116	Remedies	6cp
76xxx	Law elective 3	6cp
50xxx	Journalism Strand subject (300 level)	8cp

Year 5**Stage 9**

76xxx	Law elective 4	6cp
50177	Professional Practice and Culture	8cp
50xxx	Elective subject (Faculty of Humanities and Social Science)	8cp

Stage 10

	Legal practice major (PLT)	24cp
	<i>or</i>	
	Four Law electives	24cp

Bachelor of Arts in Communication (Media Arts and Production)/ Bachelor of Laws

Course code: LLI1

This course enables students to bring to their work in the media arts industries and professional media practices, an interdisciplinary background in humanities, social sciences, communication and cultural studies. They will be able to create new industries as well as reshape existing ones.

Year 1**Stage 1**

50116	Media Arts and Production 1	6cp
50109	Power and Change in Australia	6cp
50107	Contemporary Cultures 1	6cp
50105	Communications and Information Environments	6cp

Stage 2

70113	Legal Process and History	10cp
70105	Legal Research	4cp
50108	Contemporary Cultures 2	6cp
50117	Media Arts and Production 2	6cp

Year 2**Stage 3**

70217	Criminal Law	6cp
70211	Law of Contract	8cp
50xxx	Media Arts and Production Strand subject (200 level)	8cp

Stage 4

70311	Law of Tort	8cp
70616	Federal Constitutional Law	8cp
50136	Culture and Screen	8cp

Year 3**Stage 5**

70318	Personal Property	4cp
70317	Real Property	8cp
76xxx	Law elective 1	6cp
50xxx	Media Arts and Production Strand subject (200 level)	8cp

Stage 6

70417	Corporate Law	8cp
70617	Administrative Law	8cp
50xxx	Media Arts and Production Strand subject (200 level)	8cp

Year 4

Stage 7

70516	Equity and Trusts	8cp
71005	Practice and Procedure	4cp
76xxx	Law elective 2	6cp
50xxx	Cultural Studies Project 1	8cp

Stage 8

71216	Law of Evidence	6cp
71116	Remedies	6cp
76xxx	Law elective 3	6cp
50xxx	Media Arts and Production Strand subject (300 level)	8cp

Year 5

Stage 9

76xxx	Law elective 4	6cp
50198	Media Arts Project	8cp
50xxx	Elective subject (Faculty of Humanities and Social Science)	8cp

Stage 10

	Legal practice major (PLT)	24cp
	<i>or</i>	
	Four Law electives	24cp

Bachelor of Arts in Social Science/Bachelor of Laws

Course code: LL12

This course concentrates on intellectual problem solving and the development of analytical skills rooted in an historical, political and social awareness of knowledge and its uses.

Year 1

Stage 1

50120	Introduction to Social Inquiry	6cp
50105	Communication and Information Environments	6cp
50109	Power and Change in Australia	6cp
50107	Contemporary Cultures	6cp

Stage 2

70113	Legal Process and History	10cp
70105	Legal Research	4cp
50121	Theory and Method	6cp
50111	Modernity and Colonialism	6cp

Year 2

Stage 3

70217	Criminal Law	6cp
70211	Law of Contract	8cp
50164	Research Methods 1	8cp

Stage 4

70311	Law of Tort	8cp
70616	Federal Constitutional Law	8cp
50142	Social Theory	8cp

Year 3

Stage 5

70318	Personal Property	4cp
70317	Real Property	8cp
50xxx	Social Inquiry Strand subject (200 level)	8cp
76xxx	Law elective 1	6cp

Stage 6

70417	Corporate Law	8cp
70617	Administrative Law	8cp
50xxx	Social Inquiry Strand subject (200 level)	8cp

Year 4

Stage 7

70516	Equity and Trusts	8cp
71005	Practice and Procedure	4cp
76xxx	Law elective 2	6cp
50xxx	Social, Political and Historical Studies, Disciplinary Strand Subject (300 level)	8cp

Stage 8

71216	Law of Evidence	6cp
71116	Remedies	6cp
76xxx	Law elective 3	6cp
50xxx	Social Inquiry Strand subject (300 level)	8cp

Year 5

Stage 9

76xxx	Law elective 4	6cp
50217	Professional Placement	8cp
50xxx	Elective subject (Faculty of Humanities and Social Science)	8cp

Stage 10

	Legal practice major (PLT)	24cp
	<i>or</i>	
	Four Law electives	24cp

COMBINED DEGREES

The Law Faculty offers a combined degree with the the Institute for International Studies (LLB BA). The degree is of five years' duration and students undertake studies full time with classes held throughout the day and evening. The program will allow students the option to undertake a Practical Legal Training (legal practice) major as part of their undergraduate studies. Subsequently, graduates will be able to proceed, subject to the availability of places, into the Graduate Certificate in Continuing Legal Practice to complete the remaining component of the PLT requirements.

Alternatively, students may choose to complete their undergraduate degree from the choice of electives.

Bachelor of Laws/ Bachelor of Arts in International Studies

Course code: LL07

The Bachelor of Laws/Bachelor of Arts in International Studies program is offered jointly by the Faculty of Law and the Institute for International Studies. The degree provides full-time study for students wishing to obtain a professional qualification that satisfies the basic academic requirements of the Supreme Court of New South Wales for admission as a legal practitioner. A single testamur of LLB BA (International Studies) is awarded. The LLB component may be awarded with First or Second Class Honours. The program is designed for students who wish to obtain an international perspective and expertise to enable them to work overseas, provide specialised legal services to Australian ethnic communities, and satisfy the demand in firms for legal practitioners who can act for foreign investors.

In addition to pursuing the full program of the Bachelor of Laws, students are required to follow a major – a country or region of specialisation – in the International Studies program. Students study language and culture for at least two years in Sydney, and this is followed by a period of study overseas. The following majors are offered: Argentina, Australia and the Asia-Pacific Region, Chile, China, Croatia, France, Germany, Greece, Indonesia, Italy, Japan, Latin America,

Malaysia, Mexico, Poland, Russia, Slovenia, South China, South-East Asia, Spain, Taiwan, Thailand and Ukraine.

Students are admitted to the International Studies program with no guarantee of entry to a specific major, although every effort is made in trying to meet students' preferences. The Institute reserves the right to allocate places in majors according to its resources and arrangements with overseas universities.

In general, there are no prior language requirements for the International Studies component of this combined degree, however, some majors within the International Studies program do have specific admission requirements. Entry to the Greece, Poland, Slovenia and Ukraine majors is restricted to students who have a sound working knowledge of the language of their selected specialisation.

Each student's choice of major and subjects to study in the International Studies program requires the approval of the Board of Studies of the Institute for International Studies.

In exceptional circumstances, students may, with the approval of the Board of Studies of the Institute for International Studies, vary the designated subjects in their International Studies major. Refer to the List of Approved Substitute Subjects in this handbook.

All students are required to complete four consecutive semesters of study of Language and Culture before proceeding to In-country Study. There are different classes available for students with different levels of language proficiency.

The Institute for International Studies makes the arrangements for students to spend two semesters of In-country Study at an institution of higher education in a country of their major. The costs of tuition in host institutions overseas and travel between Sydney and the designated host institutions are borne by UTS except in cases where a scholarship has been awarded to the student with provision for these costs. Under those circumstances, the funds that would have otherwise been allocated towards the student's tuition and travel will be redirected to support the In-country Study program in general. In most cases the cost of living for the period of In-country Study will not exceed the cost of living away from home in Sydney. However, students should be aware that the cost of living in some countries – notably Argentina, France, Germany, Hong Kong, Japan and Taiwan – maybe higher than in Sydney.

Course structure

All Law subjects are taught over one semester. Students attend 12–15 hours of lectures and seminars per week. Students may be required to attend evening classes. The degree normally requires five years of full-time study for completion. For the International Studies component, students are required to complete a sequence of four subjects in Language and Culture; a subject in Contemporary Society; two semesters of study at an overseas university or institution of higher education; and a subject entitled International Legal Studies.

Course program

Stage 1

70113	Legal Process and History	10cp
70105	Legal Research	4cp
76600	International Legal Studies	8cp

Stage 2

70217	Criminal Law	6cp
70211	Law of Contract	8cp
976xxx	Contemporary Society	8cp

Stage 3

70311	Law of Tort	8cp
70616	Federal Constitutional Law	8cp
971xxx	Language and Culture 1	8cp

Stage 4

70317	Real Property	8cp
70318	Personal Property	4cp
76xxx	Elective subject 1	6cp
972xxx	Language and Culture 2	8cp

Stage 5

70417	Corporate Law	8cp
70617	Administrative Law	8cp
973xxx	Language and Culture 3	8cp

Stage 6

70516	Equity and Trusts	8cp
76xxx	Elective subject 2	6cp
974xxx	Language and Culture 4	8cp

Stage 7

977xxx	In-country Study 1	24cp
--------	--------------------	------

Stage 8

978xxx	In-country Study 2	24cp
--------	--------------------	------

Stage 9

71005	Practice and Procedure	4cp
71116	Remedies	6cp
71216	Law of Evidence	6cp
76xxx	Elective subject 3	6cp
76xxx	Elective subject 4	6cp

Stage 10

Legal practice major (PLT)	24cp
<i>or</i>	
Four Law electives	24cp

Further details of International Studies subjects may be found in the *Institute for International Studies Handbook*. Queries regarding the International Studies component of the course should be addressed to the Institute itself on 9514 1574.

Combined degree students are required to confirm, during the University enrolment period, the subjects they intend to take for the year with the Institute at 9-11 Broadway on the City campus (next door to the Co-op Bookshop).

UNDERGRADUATE SUPPLY PROGRAMS

Information and inquiries:

Administrative Assistants

Ms Vikki John

Telephone: 9514 3749

Ms Shirley Turnbull

Telephone: 9514 5459

Academic advice may be obtained from the:

Director of Undergraduate Supply Program

Associate Professor Michael Adams

Telephone: 9514 5418

The Faculty of Law presents 'Supply' Law courses – that is, studies in various strands of the law for students who are not aiming for a legal qualification, but who wish to become familiar with the law as it affects their chosen profession. Through its Supply program, the Faculty of Law presents courses to students in the Faculties of Business, Engineering, Nursing and Science.

Undergraduate supply subjects

The following subjects are offered by the Faculty of Law to undergraduate students enrolled in Business, Engineering, Nursing and Science degrees.

79001	Legal Issues and Disadvantaged Groups	3cp
79002	Legal Aspects of Human Reproduction and Child Protection	3cp
79003	Health Care Law	3cp
79161	Introduction to Insolvency Law	6cp
79162	Corporate Insolvency and Administration	6cp
79202	Business Law	4cp
79211	Law for Marketing Management	6cp
79264	Securities Markets Regulation	6cp
79270	Industrial and Labour Law	6cp
79360	Insurance Contracts	6cp
79365	Company Law	6cp
79366	Banking Law	6cp
79370	Law and Contracts	3cp
79371	Legal Issues in Telecommunications	6cp
79403	Law and the Manager	6cp
79404	Law for Third Sector Managers	6cp
79411	Advanced Companies and Securities Law	6cp
79462	Revenue Law	6cp
79502	Law and Finance	6cp
79603	International Business Law and Regulation	6cp
79606	Advanced Revenue Law	6cp
79659	Advanced Commercial Law	6cp

79660	Environmental Law in Business	6cp
79662	Business Bankruptcy	6cp
79666	International Aspects of Australian Taxation Law	6cp
79667	Indirect Taxation	6cp
79701	Stamp Duties	6cp
79702	Land Tax and Payroll Tax	6cp
79703	Legal Aspects of Contracts Administration	6cp
79706	Customs Duties/Levies	6cp
79707	International Taxation 2	6cp
79708	Contemporary Business Law	6cp
79711	Advanced Industrial Law	6cp
79718	Advanced Taxation	6cp
79731	Industrial Law	6cp
79733	Companies and Securities Law	6cp
79741	Marketing Legislation in Australia	6cp
79742	International Business Law	6cp
79749	Law for Managers – Administration	6cp
79752	Employment Legislation	6cp
79753	Current Issues in Industrial Law	6cp
79760	Applied Legal Research	6cp
79667	Indirect Taxation	6cp
79762	International Taxation 1	6cp
79763	Contemporary Issues in Taxation	6cp
79771	Dispute Resolution (S)	6cp
79781	Readings in International Business Law	6cp
79791	Business Law Project	6cp
79793	Law for Managers – Health	6cp
79794	Legal Issues for Community Managers	6cp
79811	Taxation Module	6cp
79990	Legal System	4cp
79991	Forensic Science Case Study	6cp

Why is an understanding of the law important?

Increasingly, the modern environment requires an understanding of legal issues. Many areas are governed by complicated laws and regulations. The purpose of the Supply program is to foster an awareness of the role of law as a key strategic tool; to equip potential executives with the knowledge to deal with the legal aspects of their particular profession. It is inevitable that anyone in a responsible position in a profession, commerce or the public service will need to develop a specialist knowledge of particular branches of the law. The breach of a key legal provision could result in an otherwise advantageous arrangement being rendered totally ineffective, or worse, being penalised.

As well as undertaking 'core' Law subjects as part of their major, Bachelor of Business students have the opportunity to select a Law sub-major – Business, Taxation or Foundations in Law. The Law sub-majors are designed to help students develop the knowledge and skills necessary to recognise legal pitfalls and to react appropriately. Students are, of course, also taught to utilise the law to achieve legitimate success. This is particularly true in the accounting and management professions.

Sub-major in Business Law

As can be seen from the list of units offered, the Business Law sub-major affords students a wide range of areas to choose from. It should be noted, however, that not all subjects listed will be offered each semester. Units offered in the Business Law sub-major include:

79161	Introduction to Insolvency Law	6cp
79162	Corporate Insolvency – Administration	6cp
79211	Law for Marketing Management	6cp
79270	Industrial and Labour Law	6cp
79360	Insurance Contracts	6cp
79365	Company Law	6cp
79366	Banking Law	6cp
79403	Law and the Manager	6cp
79462	Revenue Law	6cp
79502	Law and Finance	6cp
79603	International Business Law and Regulation	6cp
79659	Advanced Commercial Law	6cp
79660	Environmental Law in Business	6cp
79662	Business Bankruptcy	6cp
xxxxx	One subject from the Taxation Law sub-major	6cp

Sub-major in Taxation Law

The Taxation Law sub-major offers an integrated sequence of subjects enabling students to specialise in this important area of law, applicable to the business and public sectors of Australia and its international relationships. Taxation is the ultimate interface of law, accounting and business enterprises, and always requires specialist knowledge.

Students will select four units from the following:

79606	Advanced Revenue Law	6cp
79666	International Aspects of Australian Taxation Law	6cp
79667	Indirect Taxation	6cp
	<i>either</i>	
79411	Advanced Companies and Securities Law	6cp
	<i>or</i>	
79264	Securities Market Regulation	6cp

Sub-major in Foundations in Law

This sub-major is for students enrolled in the Bachelor of Business/Bachelor of Laws degree, and students considering transferring between the different degree programs.

Students are required to study the following Law degree subjects:

70211	Law of Contract	8cp
70311	Law of Tort	8cp
70317	Real Property	8cp

Postgraduate courses

Course information and inquiries

Administrative Officer (Postgraduate)

Paul Holt

Telephone: 9514 3756

Fax: 9514 3400

Administrative Assistant (Postgraduate)

Vacant

Telephone: 9514 xxxx

Fax: 9514 3400

Administrative Secretary (Postgraduate)

Mrs Nola Grierson

Telephone: 9514 3754

Fax: 9514 3400

*Academic advice may be obtained from
the Director of Postgraduate Programs*

Dr David Meltz

Telephone: 9514 3757/5107

Fax: 9514 3400

University Graduate School

Inquiries in relation to application requirements, scholarships, fees and other administrative issues should be directed to the University Graduate School.

For inquiries about admissions,
telephone: 9514 1523.

For inquiries about fees or records,
telephone: 9514 1520.

For inquiries about scholarships,
telephone: 9514 1521.

Rules for postgraduate students

Candidates should consult the *UTS Calendar* or the *Postgraduate Student Handbook* for relevant rules. Copies of the *UTS Calendar* may be purchased from the Co-op Bookshop, and are also held in the University Library.

Exemptions

Exemptions are not granted for **elective** subjects on the basis of subject(s) undertaken towards another completed academic program, or for studies not undertaken at the postgraduate level. However, requests for exemptions from **core** subjects on the basis of subject(s) undertaken towards either another completed or uncompleted academic program will be looked at on a case-by-case basis.

Applications for exemption will not be considered until **after** enrolment. Certified

copies of academic transcripts and details of the subject content and assessment must be produced for each exemption sought.

As a general rule, exemptions may be granted for subjects studied less than six years ago. In subjects where there has been significant recent change in the law, the granting of exemptions will be at the discretion of the Subject Exemptions Sub-committee of the Faculty Board.

Fee exemptions

In some cases, postgraduate candidates may make an application to the Faculty for exemption from postgraduate course fees on the grounds of financial hardship. Candidates who are granted exemption from postgraduate course fees will be charged HECS by the deferred taxation method for their program of study. Applications for fee exemptions must be made at the commencement of each semester of enrolment. Application forms and further details on postgraduate fee exemptions are available from the University Graduate School.

Cross-institutional enrolment

Subject to approval by the Director of Postgraduate Programs, candidates may undertake subjects in postgraduate programs at other universities. Applications to take subjects at overseas universities will also be considered.

A formal application, detailing the academic content, attendance and assessment requirements of the subject(s) proposed to be completed, must be made to the Director of Postgraduate Programs before enrolling with the other institution.

Scholarships

Information about the various scholarships available to postgraduate candidates is available from the University Graduate School, telephone 9514 1521. Applications for scholarships close at the end of October each year.

International candidates should note that, as scholarship positions vary from country to country, they should contact the Australian embassy in their country of origin to receive current information.

Fees

Australian residents

Course	Abbreviation	Code	CP	1998 fee (A\$)
Doctor of Juridical Science	SJD	LL53	48	6,000
Master of Laws (by coursework)	LLM	LL52	48	6,000
Master of Taxation Law	MTax	LL58	48	6,000
Master of Legal Studies	MLS	LL68	62	7,750
Graduate Diploma in Legal Studies	GradDipLS ¹	LL67	50	6,250
Master of Dispute Resolution	MDR	LL59	54	9,000
Graduate Certificate in Dispute Resolution	GCDR ¹	LL69	24	4,000
Graduate Certificate in Legal Practice	GCLP ¹	LL70	24	HECS liable ³
Graduate Certificate in Legal Practice (PG fees)	GCLP ¹ (fees)	LL72	24	4,000
Graduate Certificate in Continuing Legal Practice	GCCLP	LL71	24	HECS liable ³
Graduate Certificate in Continuing Legal Practice (PG fees)	GCCLP ¹ (fees)	LL73	12	1,000
Graduate Diploma in Law for Secondary Teachers	GradDipLaw ¹	LL64	48	HECS liable
Graduate Certificate in Law for Secondary Teachers	GCLST ¹	LL66	24	HECS liable
Doctor of Philosophy	PhD	LL54	–	contact University Graduate School
Master of Laws (by thesis)	LLM	LL51	–	HECS liable
Graduate Diploma in Australian Law	GradDipAustLaw ¹	LL57	48	6,000

The fees quoted above are the overall cost of the program in 1998. Fees are charged per semester according to the credit-point value of the subject(s) in which the student is enrolled. In most cases students could expect to pay \$125 per credit point². For example, a standard one-semester subject is worth six credit points and the tuition fee for such a subject would be \$750.

All students are also required to pay annual Student Union and service fees.

¹ These degree abbreviations are used for the sake of convenience; they are not official UTS course abbreviations.

² Does not include MDR (LL59), GCDR (LL69) or courses for international students.

³ Available to UTS LLB Graduates only.

Note: External award and non-award students should contact the External Award Office, telephone 9514 1559.

International students

Course	Abbreviation	Code	CP	1998 fee (A\$)
Master of Comparative Law	MCL	LL63	48	11,000
Master of Laws (by coursework)	LLM	LL52	48	11,000
Master of Legal Studies	MLS	LL68	62	11,000
Master of Dispute Resolution	MDR	LL59	54	11,000
Graduate Diploma in Legal Studies	GradDipLS	LL67	50	8,850
Graduate Diploma in Australian Law	GradDipAustLaw	LL57	various	8,000 ¹
Graduate Certificate in Comparative Law	GCCL	LL56	24	3,300
Graduate Certificate in Dispute Resolution	GCDR	LL69	24	5,500
Master of Laws (by thesis)	LLM	LL51	–	11,000
Doctor of Juridical Science	SJD	LL53	48	11,000
Doctor of Philosophy	PhD	LL54	–	8,110 p.a.

¹ \$4,000 per semester; most students require at least two semesters to complete.

Deferment of enrolment

Deferment in the first semester of enrolment is not available for postgraduate programs offered by UTS. Offers of admission that are not accepted lapse on the date of enrolment. Applicants who do not accept an offer of admission should therefore re-apply at the next intake.

Provision of documentation relating to postgraduate applications

Applicants to any program should note the following University requirements:

- All applications and associated documentation must be sent directly to the University Graduate School. Do not send any material to the Faculty.
- Original or certified copies of your documentation must be submitted. It is recommended that copies certified by the issuing authority or by an Australian university (e.g. UTS Information Service) be provided. UTS will also accept copies of an original document where verified by a certified accountant; a bank manager; a barrister or solicitor; a postal manager; a school principal; the university admission centre of any Australian State; an Australian overseas diplomatic mission; or a police officer at or above the rank of sergeant. Persons verifying the original documents must provide their signature and telephone number and affix the official stamp or seal of their organisation on the copy. **Photocopies certified by a Justice of the Peace will not be accepted.**

Application procedures – coursework and research programs

Applicants should complete either a UTS Application for Admission – Postgraduate Courses form (for coursework); an – Application for Candidature – Doctoral Degrees Application form (for the PhD or SJD research programs); or an Application for Candidature – Master’s Degree by Thesis form (for the LLM by thesis program). These forms are available from the University Graduate School, the UTS Information Service or the Faculty of Law.

Completed applications, including certified copies of the academic transcripts for all qualifications the applicant has obtained and a full curriculum vitae, should be addressed

to the Registrar if lodged by post, or if lodged in person may be handed to staff at the UTS Information Service, Level 4, City campus, Broadway. Certified copies of original documentation can be made at the UTS Information Service if required.

Most coursework applicants may apply for admission at three stages (check the entry for your proposed program):

Summer program: Applications for the Summer program close at the beginning of October each year. Applicants are notified about their application in November. Enrolment will take place in mid-November.

Autumn semester: Applications for the Autumn semester close at the end of October each year. Applicants are notified about their application in late January. Enrolment takes place in February.

Spring semester: Applications for the Spring semester close at the end of May each year. Applicants are notified about their application and enrolled in July.

Please note that the number of places available in the programs is limited. However, all appropriately qualified persons are encouraged to submit an application. Applications are assessed in the first instance by the Director of Postgraduate Programs and UTS staff will not speculate as to an applicant’s likelihood of success.

Overseas students

Applicants must satisfy the English language proficiency requirements of the University, which require international candidates to have a minimum International English Language Testing System (IELTS) score of 6.5 before enrolling in postgraduate studies. For further details contact the International Programs Office, PO Box 123, Broadway 2007 Australia, telephone 61 2 9514 1531, fax 61 2 9514 1530.

Owing to student visa restrictions international candidates must enrol on a full-time basis only.

Applicants who are not permanent residents of Australia should complete a UTS International Programs Application for Admission form, available from the International Programs Office. Completed applications, with originals or certified copies of all supporting documents, should be addressed to the Director of International Programs. Applications by non-residents should be accompanied by the A\$50 application fee (non-refundable).

Attendance

Most postgraduate award programs can be undertaken on a full-time or part-time basis. Please note, because of visa requirements, international students must study full time. A number of different attendance modes are available.

The majority of postgraduate subjects are offered within the Autumn and/or Spring semesters. As a guideline, a six-credit-point subject offered within the Autumn semester would normally require attendance of two hours each week over a 14-week semester. Lectures are usually scheduled in the evenings, commencing no earlier than 5.30 p.m.

Autumn semester – March to June 1998

Spring semester – August to November 1998

The Faculty offers a number of postgraduate subjects in an intensive attendance mode in the Summer and July Intensive programs. In Summer and July Intensive program subjects, the contact hours are equivalent to those of one- or two-semester subjects, but lectures are held daily over a concentrated period. For example, a six-credit-point subject offered in the Summer program may require students to attend for two-and-a-half hours per day over 10 days. Intensive program candidates may be required to commence preparation in advance of the lectures.

This attendance mode is particularly suited to interstate or international candidates who may complete their coursework requirements in the Intensive programs. However, students may not undertake subjects totalling more than 24 credit points in any one Intensive program.

In 1998, the Summer program will be held in January; further intensive classes will be held in July. Some courses are not taught in Intensive programs. Please check the individual course entry.

Some postgraduate subjects, such as the Research Project, Research Paper and the International Comparative Law Project, do not require formal attendance at the Faculty, and may be completed externally, subject to appropriate academic supervision arrangements.

Assessment

While assessment varies from subject to subject, students may be required to do one or more of the following: final examinations, informal examinations, take-home examinations, assignments, research work, class participation, presentation of seminar papers or a *viva voce*.

Coordinating examiners will advise students of the mode of assessment for their subjects by notice by the end of the third week of the semester.

The written assessment for a six-credit-point subject will normally total 6,000–7,500 words; the written assessment for a 12-credit-point subject will normally total 12,000–15,000 words.

Formal requirements

Essays and other written work should be prepared in accordance with the guidelines laid down in the Faculty of Law's *Guide to Essay Writing*, which may be obtained from the Faculty administration (price as at 1997: A\$2.50).

Mandatory continuing legal education

Participation in postgraduate study may entitle candidates to MCLE points. If this particular educational activity is relevant to students' immediate or long-term needs in relation to their professional development and practise of the law, they may claim one 'unit' per hour of attendance – refreshment breaks not included. For further details contact the Law Society of NSW.

Transfers to other postgraduate programs

Candidates who wish to transfer to other postgraduate degree programs offered by the Faculty of Law must meet admission criteria (see the individual entries in this handbook for further details).

Doctor of Philosophy

Course code: LL54

A candidate for the Doctor of Philosophy (PhD) is required to submit a thesis of approximately 100,000 words representing an original contribution to the knowledge of a subject. Applicants should contact the Director of Postgraduate Programs to discuss their proposed program of study **before** they submit their application.

Admission requirements

Candidates for the PhD must have a Master's degree, or a Bachelor's degree with First Class Honours or Second Class Honours (Division 1).

Candidates will also be required to provide satisfactory evidence of their ability to undertake advanced research appropriate to their Doctoral program.

Areas of research interest

The academic staff of the Faculty have research interests in the following areas: dispute resolution; business law (national and international), particularly in relation to banking and finance; Chinese law, in particular foreign investment, copyright and dispute resolution; comparative law; computer law and computerised legal retrieval; environmental law; European Union law; family law; human rights law; intergovernmental immunity; international law, including international migration law, international relations, and international trade and financial law; intellectual and industrial property law; joint ventures and trade agreements; jurisprudence; legal drafting; legal philosophy; legal research and selected aspects of legal history; local government; statutory interpretation; tort law; trade law.

This list is intended as a guide only and proposals for supervision of research degrees in other areas may be considered.

Transfer from LLM (by thesis)

Candidates in the LLM (by thesis) program may apply to transfer to the PhD after a minimum of one year's study, and after having reached a standard equivalent to that of a Bachelor's degree with First Class Honours or Second Class Honours (Division 1). Candidates applying to transfer must demonstrate, with the support of their supervisor(s), that their topic has Doctoral

scope. Final approval of the transfer resides with the University Graduate School Board.

Dissertation topic

PhD candidates must provide details of their proposed topic when they submit their application. The topic will then be submitted to the Faculty's Graduate Studies Committee for approval. Final approval for the admission of candidates, supervision arrangements and choice of topics resides with the University Graduate School Board. Once final approval is obtained, the topic cannot be changed except with the approval of these committees.

Supervision

So that a Doctoral degree candidate may be guided and supervised properly, there shall be at least two supervisors, one to be the principal supervisor and one to be the co-supervisor. Normally at least one of the supervisors shall have a Doctoral degree. At least one of the supervisors shall be an academic staff member of the University, and shall be responsible for reporting progress and other matters to the University Graduate School Board. Candidates are required to meet with their supervisor(s) at least once a month, to discuss the research being undertaken.

Progress reports

At the end of each semester of candidacy, PhD candidates must submit a report to their principal supervisor detailing their progress to date. The supervisor will indicate whether progress is satisfactory or unsatisfactory.

Doctoral Assessment

PhD candidates are required to undergo a Doctoral Assessment within the first year of candidacy. The object of the Assessment is to ensure that candidates are equipped with the knowledge to carry out their research program, and have made sufficient progress to complete their program within the prescribed time.

The form of the Doctoral Assessment for each course will be determined by the University Graduate School Board, on the recommendation of the Responsible Academic Officer. As part of the Assessment, candidates will normally present a seminar to the University on their dissertation topic and methodology, of approximately one hour's duration.

Candidates who do not satisfy the requirements for the Doctoral Assessment will not be

permitted to proceed with their candidacy unless, with the approval of the Academic Board, they are invited to re-attempt the Assessment.

Attendance

PhD candidates are not normally required to attend classes, though some coursework may be required before commencing the thesis. Regular contact should be maintained with the supervisor(s) throughout a candidate's enrolment. Candidates must comply with the University Graduate School Board's Code of Practice for Supervisors and Doctoral Candidates.

Interstate and international applicants should note that some attendance in Sydney is a requirement.

Minimum and maximum enrolment periods

The PhD program requires the following **minimum** enrolment periods:

For candidates with a Master's degree, the program may be completed in a **minimum** of four semesters of full-time enrolment, or six semesters of part-time enrolment. For candidates with a Bachelor's degree (Honours), the program may be completed in a **minimum** of six semesters of full-time enrolment, or eight semesters of part-time enrolment.

Regarding the **maximum** enrolment period, full-time students must submit their thesis not later than 10 semesters from the date of their registration; for part-time students, the **maximum** time allowed is 15 semesters from the date of their registration.

Candidates must lodge a Notification of Intent to Submit a Thesis form with the University Graduate School **at least two months before** submitting their thesis. Information about the requirements on the presentation and format of the thesis will be forwarded to candidates when this form is lodged.

Oral Presentation

Candidates are required to make an Oral Presentation of the thesis within the final six months before the submission of the thesis.

This is in addition to the Doctoral Assessment which is required in the early stages of enrolment in the PhD program.

Application procedures

Applicants for the PhD degree should contact the Director of Postgraduate Programs to discuss their proposed program of study **before** submitting their application.

They should complete a UTS Doctoral Degrees Application for Admission form, available from the University Graduate School, the UTS Information Service or the Faculty of Law.

PhD applications may be lodged at any stage of the academic year.

All applicants will receive notification in writing of the success of their application.

The process of having a dissertation topic approved and supervisors appointed usually takes two to three months.

Doctor of Juridical Science

Course code: LL53

The Doctor of Juridical Science (SJD) program offered by the Faculty of Law was the first degree of its kind in Australia. It combines coursework and original research culminating in a Doctoral dissertation. With this unique combination of coursework and research, the SJD program counters the isolation experienced by many PhD candidates. The SJD program provides candidates with the opportunity to develop their Doctoral topic through their coursework program, and allows candidates to benefit from contact with other postgraduate candidates and the academic staff of the Faculty.

A candidate for the SJD program must complete coursework totalling 48 credit points. A brief description of the subjects offered by the Faculty is outlined at the end of this handbook; detailed descriptions are available from the Administrative Secretary (Postgraduate).

After completion of the coursework component, the SJD candidate undertakes a Doctoral dissertation. The dissertation must represent an original contribution to a field of study, and have a legal focus and analysis. It should be approximately 50,000–70,000 words in length. **All coursework requirements must be completed before the dissertation is commenced.**

Admission requirements

Candidates for the SJD program must have a Master's degree in Law, or a Bachelor's degree with First Class Honours or Second Class Honours (Division 1). Candidates are also required to provide satisfactory evidence of their ability to undertake advanced research appropriate to their Doctoral program.

Transfer from other postgraduate programs

It may be possible to transfer to the SJD in accordance with the University Rules. For more information contact the University Graduate School, or the Faculty of Law.

Dissertation topic

As the SJD degree is a professional legal qualification, dissertation topics should have a legal focus and analysis. Topics which principally involve non-legal techniques (such as sample surveys) or the application of non-legal categories (e.g. principles of explanation of other disciplines such as those of psychology or sociology) would **not** qualify. In such cases students would be counselled to pursue the PhD. SJD candidates should submit proposals for dissertation topics to the Director of Postgraduate Programs before lodging their application. Proposals will then be submitted for the approval of the Faculty's Graduate Studies Committee. Final approval for the admission of candidates, dissertation topic and supervision arrangements resides with the University Graduate School Board. Once final approval is obtained, the topic cannot be changed except with the approval of these committees.

Supervision

Candidates should discuss the supervision of their Doctoral program with the Director of Postgraduate Programs when they submit their proposed topic. So that a Doctoral degree candidate may be guided and supervised properly, there shall be at least two supervisors, one to be the principal supervisor and one to be the co-supervisor. Normally at least one of the supervisors shall have a Doctoral degree. At least one of the supervisors shall be an academic staff member of the University, and shall be responsible for reporting progress and other matters to the University Graduate School Board.

Progress reports

At the end of each semester of enrolment in the dissertation component, candidates must submit a report to their principal supervisor detailing their progress to date. The supervisor will indicate whether progress is satisfactory or unsatisfactory.

Doctoral Assessment

SJD candidates are required to undergo a Doctoral Assessment within the first year of enrolment in the dissertation component. The object of the Assessment is to ensure that candidates are equipped with the knowledge to carry out their research program, and have made sufficient progress to complete their program within the prescribed time.

The form of the Doctoral Assessment for each course will be determined by the University Graduate School Board, on the recommendation of the Responsible Academic Officer. As part of the Assessment, candidates will normally present a seminar to the University on their dissertation topic and methodology of approximately one hour's duration.

Candidates who do not satisfy the requirements for the Doctoral Assessment will not be permitted to proceed with their candidacy unless, with the approval of the Academic Board, they are invited to re-attempt the Assessment.

Minimum and maximum enrolment periods

The SJD program requires the following minimum enrolment periods:

For candidates with a Master's degree, the program may be completed in a **minimum** of four semesters of full-time enrolment or six semesters of part-time enrolment. For candidates with a Bachelor's degree (Honours), the program may be completed in a **minimum** of six semesters of full-time enrolment or eight semesters of part-time enrolment.

Regarding the **maximum** enrolment period, full-time students must submit their dissertation no later than 10 semesters from the date of their registration; for part-time students, the **maximum** time allowed for completion of all academic requirements is 15 semesters from the date of their registration. Since the SJD degree is primarily a research degree, the recommended full-time enrolment

pattern is a minimum two semesters of coursework and four semesters of research.

The recommended part-time enrolment pattern is a minimum of four semesters of coursework and eight semesters of research.

Oral Presentation

Candidates are required to make an Oral Presentation of the dissertation in the final six months before the submission of the dissertation.

Application procedure

The process of having a dissertation topic approved and supervisors appointed usually takes two to three months. Applicants need to have their dissertation topic approved before commencing the coursework component. The first step is to contact the Director of Postgraduate Programs in the Faculty of Law to discuss the proposed research topic **before** submitting a formal application. Applicants should then complete a UTS Doctoral Degrees Application for Admission form, available from the University Graduate School, the UTS Information Service or the Faculty of Law.

Master of Laws (by thesis)

Course code: LL51

A candidate for the Master of Laws (by thesis) (LLM) is required to submit a thesis of approximately 40,000–60,000 words, representing an original investigation, criticism or review of a field of legal research, of a standard suitable for publication.

Applicants should contact the Director of Postgraduate Programs to discuss their proposed thesis topic **before** submitting their application.

Areas of research interest

The particular postgraduate research interests of academic staff are listed at the back of this handbook under 'Research interests of staff'.

Admission requirements

Candidates for the LLM (by thesis) must have an LLB degree or equivalent qualification, must demonstrate competence in the area of research and may be required to satisfy other additional requirements.

Final approval for the admission of candidates and choice of topics resides with the University Graduate School Board.

Dissertation topic

LLM (by thesis) candidates must provide details of their proposed topic when they submit their application. The topic will then be submitted to the Faculty's Graduate Studies Committee for approval. Final approval for the admission of candidates, and choice of topics resides with the University Graduate School Board. Once final approval is obtained, the topic cannot be changed except with the approval of these committees.

Supervision

LLM (by thesis) candidates must discuss the supervision of their Doctoral program with the Director. Supervisors will be appointed from within the full-time staff of the Faculty of Law. Subject to approval, an external co-supervisor may also be appointed. Candidates are required to meet with their supervisor/s at least once a month, to discuss the research being undertaken.

Progress reports

At the end of each semester of candidacy, LLM (by thesis) candidates must submit a report to their principal supervisor detailing their progress to date. The supervisor will indicate whether progress is satisfactory or unsatisfactory.

Thesis Assessment

LLM (by thesis) candidates are required to undergo a Thesis Assessment within the first year of enrolment in the dissertation component. The object of the Assessment is to ensure that candidates are equipped with the knowledge to carry out their research program, and have made sufficient progress to complete their program within the prescribed time.

The Thesis Assessment may take the form of a written or oral examination. As part of the Assessment, candidates will normally present a seminar to the University on their dissertation topic and methodology of approximately one hour's duration.

Candidates who do not satisfy the requirements for the Thesis Assessment will not be permitted to proceed with their candidacy unless, with the approval of the Academic Board, they are invited to re-attempt the Assessment.

Attendance

Candidates are not normally required to attend formal classes, though some coursework may be required before commencing the thesis topic. Monthly contact must be maintained with the supervisors throughout a candidate's enrolment. Candidates should comply with the University Graduate School Board's Code of Practice for Supervisors and Master's (by thesis) Candidates.

Minimum and maximum enrolment periods

The program may be completed in a **minimum** of four semesters of full-time study or six semesters of part-time study. The **maximum** period allowed for completion of the thesis is six semesters of full-time study or nine semesters of part-time study.

Candidates must lodge a Notification of Intent to Submit a Thesis form with the University Graduate School **at least two months prior** to submitting their thesis. Information on the presentation and format of the thesis will be forwarded to candidates when this form is lodged.

Oral Presentation

Candidates are required to make an Oral Presentation of the dissertation in the final six months before the submission of the dissertation.

Application procedures

Applicants for the LLM (by thesis) should contact the Director of Postgraduate Programs to discuss their proposed thesis topic **before** submitting their application.

Applicants should complete a UTS Application for Candidature – Master's Degrees by Thesis form, available from the University Graduate School, the UTS Information Service or the Faculty of Law.

Applicants may apply for admission at any stage of the academic year.

Master of Laws (by coursework)

Course code: LL52

The Master of Laws (by coursework) program (LLM) offers candidates a wide choice of subjects and features innovative attendance patterns to suit practising professionals.

The program may be undertaken on either a full-time or part-time basis, with the majority of candidates currently enrolled on a part-time basis and completing the program over a period of two to three years.

Candidates are required to complete subjects totalling 48 credit points. Brief descriptions of the subjects offered in the program are given in this handbook in the 'Subject descriptions' section; detailed descriptions are available from the Administrative Secretary (Postgraduate).

Admission requirements

Candidates for the LLM (by coursework) program must have an LLB or high professional standing for admission as Category A applicants. They may also be required to satisfy other additional requirements.

Applicants with other legal qualifications may be admitted as Category B candidates. Applicants in this category are required to attend seminars in Advanced Legal Research in their first year of enrolment. Candidates must pass this subject and all other subjects attempted in the first year of candidacy.

The number of places available in the program each year is limited. However, all suitably qualified persons are encouraged to apply. Applications are assessed by the Director of Postgraduate Programs in the first instance, and other UTS staff will not speculate on an applicant's likelihood of success.

Majors offered in the LLM (by coursework)

A student may choose an appropriate mix of subjects to constitute a major within the LLM (by coursework) program in a specific area. The majors available are:

- Dispute Resolution
- Commercial Law
- Intellectual and Industrial Property Law
- Industrial Law
- International Law

To undertake a major, candidates must complete subjects totalling a minimum of 30 credit points within the area of the major. Honours candidates must complete subjects totalling 18 credit points **plus** the Research Project to qualify for a major. A student wishing to take more than 30 credit points in Dispute Resolution subjects should enrol in the Master of Dispute Resolution.

Course structure

Flexibility in attendance is one of the features of the LLM (by coursework) program offered by UTS. Candidates may undertake any combination of subjects offered in the different semesters, requiring a total of 48 credit points to complete the degree.

Awarding of Honours

Candidates who wish to be eligible for Honours in the Master of Laws (by coursework) are required to enrol in 77725 Research Project over two semesters. This Research Project would comprise 12 credit points of the 48 credit points required to complete the program. As the project will normally develop and extend work done in one or more of the subjects already undertaken, candidates are recommended to enrol in the project in their final two semesters. Candidates considering enrolment in the Research Project should obtain a copy of the Research Project Regulations, available from the Administrative Secretary (Postgraduate).

Candidates who enter the program under 'Category B' admission criteria are also eligible to be awarded the LLM degree with Honours. The result for the compulsory corequisite subject Advanced Legal Research is not included in calculating the average score for 'Category B' candidates.

To be eligible for Honours in the LLM by coursework, candidates must complete 77725 Research Project **and** attain an average mark of 75 per cent in their subjects.

Minimum and maximum enrolment periods

The LLM program may be completed in a **minimum** of two semesters of full-time attendance or four semesters of part-time attendance.

Maximum time periods for completion also apply:

- for a full-time student, discontinuation of registration may take place if all academic requirements for the course are not completed within six semesters from the time of registration;
- for a part-time student, discontinuation of registration may take place if all academic requirements for the course are not completed within nine semesters from the time of registration.

Master of Dispute Resolution

Course code: LL59

The Master of Dispute Resolution (MDR) is the first Master's degree in dispute resolution in Australia. The MDR is a multidisciplinary program and provides the theory, skills and practice of dispute resolution particularly related to professionals, executives and administrators. The MDR promotes understanding of and research into this developing area of legal, commercial, organisation and community application. Dispute resolution as a discipline covers dispute prevention and minimisation, dispute management, dispute resolution and dispute system design.

Admission requirements

Applicants should hold a Bachelor's degree from an Australian university, or an equivalent tertiary qualification. Applicants who have not gained the requisite tertiary qualification may be admitted if they demonstrate equivalent work experience and the ability to undertake projects at an advanced level. Completion of the qualifications of professional bodies in dispute resolution, e.g. the Institute of Arbitrators, may be accepted as proof of ability to undertake such projects. Applicants who do not hold a tertiary qualification may be offered a place in the program which is conditional, that is, the compulsory core subject must be satisfactorily completed before formal admission to the program.

Attendance

The majority of subjects focus on theory and practical skills and are taught in intensive block mode over three full-days of lectures and workshops. Subjects offered in the intensive workshop mode will have an equivalent number of contact hours to subjects offered in the traditional lecture format. In the latter subjects, seminar paper presentation days are held approximately one month after the intensive workshop. Attendance between 9.00 a.m. and 6.00 p.m. on weekdays and weekends is a requirement of the MDR program.

The majority of the MDR subjects will be offered in the Autumn and Spring semesters, though a limited number of electives are offered in the Intensive programs.

Assessment

Assessment for MDR subjects may involve a variety of methods including a research paper or papers requiring high standards of academic scholarship, seminar participation and seminar presentations. Participation in skills-based workshops will also form a significant percentage of the assessment mark. Some observation evaluations of practical skills are also used in the intensive workshops but do not contribute towards assessment for the course. The observation evaluations may be relevant when applying for accreditation with professional organisations external to the University.

The written assessment component of the introductory core subject, 77735 Dispute Resolution, requires the completion of papers totalling 12,000 words.

The six-credit-point elective subjects require the presentation of paper(s) totalling 6,000 words for each subject undertaken.

The compulsory final subject is either the Research Project or the Research Paper, which requires candidates to produce a paper of a high academic standard totalling 12,000–15,000 words and 8,000–10,000 words respectively.

Minimum and maximum enrolment periods

The MDR program may be completed in a **minimum** of two semesters of full-time attendance or five semesters of part-time attendance.

Discontinuation of registration may take place if all academic requirements for the program are not completed within nine semesters from the time of registration.

Course structure

The MDR program requires completion of subjects totalling 54 credit points. Candidates must complete two compulsory subjects: 77735 Dispute Resolution is the first compulsory subject; and 77780 Research Paper (DR) or 77781 Research Project (DR) must be completed as the final subject. The balance of subjects are taken as electives.

A typical part-time program may be:

Year 1

Semester 1

77735	Dispute Resolution (two-semester subject)	6cp
-------	--	-----

Semester 2

77735	Dispute Resolution (cont.)	6cp
77745	Negotiation	6cp

Year 2

Semester 1

77746	Advanced Mediation	6cp
77761	Dispute Resolution in Commerce	6cp

Semester 2

77760	Family Dispute Resolution	6cp
77749	Construction Industry Dispute Resolution	6cp

Year 3

Semester 1/2

77781	Research Project (DR)	12cp
-------	-----------------------	------

Electives

Electives for the MDR program may be chosen from subjects which include the following:

77746	Advanced Mediation	6cp
77752	Commercial Arbitration (Domestic)	6cp
77763	Community Dispute Resolution	6cp
77749	Construction Industry Dispute Resolution	6cp
77765	Court-based Dispute Resolution	6cp
77761	Dispute Resolution in Commerce	6cp

#tba	Work Place Dispute Resolution	6cp
77764	Environmental Dispute Resolution	6cp
77760	Family Dispute Resolution	6cp
77762	Industrial Dispute Resolution	6cp
77751	International Commercial Arbitration	6cp
77717	International Commercial Dispute Resolution ¹	12cp
77745	Negotiation	6cp
77748	Victim–Offender Dispute Resolution	6cp
77780	Research Paper (DR)	6cp
77781	Research Project (DR) ¹	12cp
77792	Crisis Negotiation	6cp

¹ Equivalent to two electives.

A limited number of electives will be offered in any one year. Brief descriptions of the subjects offered in the program are given in this handbook in the ‘Subject descriptions’ section. Detailed subject descriptions are available from the Administrative Secretary (Postgraduate).

Awarding of Honours

To qualify for Honours in the MDR, candidates must attain a minimum average mark of 75 per cent **and** must complete the two-semester subject 77781 Research Project (DR).

Master of Laws/Master of Legal Studies/Graduate Diploma in Legal Studies majoring in Dispute Resolution

Subjects offered in the MDR program may also be undertaken as part of a major in Dispute Resolution within the Master of Laws (by coursework) and the Master’s/Graduate Diploma in Legal Studies programs. To undertake a major in Dispute Resolution within the LLM/MLS/GradDipLS programs, candidates must complete Dispute Resolution subjects totalling 30 credit points, including the compulsory core subject 77735/79771 Dispute Resolution. LLM, SJD, MLS and GradDipLS candidates are limited to a **maximum** of 30 credit points of Dispute Resolution subjects. Candidates who wish to complete more than 30 credit points in dispute resolution should enrol in the MDR program.

It should be noted that the MDR program offers a more in-depth qualification in Dispute Resolution; course selection will depend upon a candidate’s career goals and other relevant considerations. Please contact the Course Coordinator or the Centre for Dispute Resolution for further details. MDR candidates will be given priority in enrolment over other candidates in any Dispute Resolution subjects.

Graduate Certificate in Dispute Resolution

Course code: LL69

The Graduate Certificate in Dispute Resolution (GCDR) is a shorter course for students who do not wish to undertake the full Master of Dispute Resolution. It will provide practical experience and skills-based tuition, with scope for students to concentrate on areas of special interest.

Admission requirements

Applicants should hold a three-year undergraduate degree from an Australian university or equivalent. Applicants who have not gained the requisite tertiary qualifications may be admitted if they demonstrate equivalent work experience and a proven ability to undertake projects at an advanced level. Admission of the second category of students will be at the discretion of the Director of Postgraduate Programs and the Course Coordinator. Admission will also be conditional upon these candidates satisfactorily completing the initial compulsory subject 79771 Dispute Resolution (S).

Attendance

The subjects in this program are taught in intensive block mode over three full days of lectures and workshops. Subjects offered in the intensive workshop mode will have an equivalent number of contact hours to subjects offered in the traditional lecture format. Seminar paper presentation days are held approximately one month after the workshop. Attendance at these follow-up days is compulsory.

Attendance between 9.00 a.m. and 6.00 p.m. on weekdays and weekends is a requirement of the program.

Course structure

Students complete the core subject and then 18 credit points of electives chosen from the following list.

Core subject

79711	Dispute Resolution (S)	6cp
-------	------------------------	-----

Electives

77745	Negotiation	6cp
77746	Advanced Mediation	6cp
77748	Victim–Offender Dispute Resolution	6cp
77749	Construction Industry Dispute Resolution	6cp
77760	Family Dispute Resolution	6cp

77761	Dispute Resolution in Commerce	6cp
77762	Industrial Dispute Resolution	6cp
77763	Community Dispute Resolution	6cp
77764	Environmental Dispute Resolution	6cp
77765	Court-based Dispute Resolution	6cp
77783	International Commercial Dispute Resolution	6cp
77792	Crisis Negotiation	6cp
#tba	Work Place Dispute Resolution	6cp

Assessment

Participation in skills programs will form a significant percentage of the assessment mark. Candidates will be required to submit research papers in each subject. For example, candidates will be required to submit a paper of 6,000–7,500 words for a subject valued at six credit points.

Transfer to the MDR

Candidates who wish to transfer to the MDR program will be required to complete a Master's qualifying subject. This will take the form of an additional six-credit-point subject 77780 Research Paper (DR). If the Master's qualifying subject is passed, candidates will not take out the Graduate Certificate in Dispute Resolution but will be transferred to the Master of Dispute Resolution with advanced standing.

Minimum and maximum enrolment periods

The GCDR program may be completed in a minimum of six months of full-time attendance or one year of part-time attendance.

Discontinuation of registration may take place if all academic requirements for the program are not completed within four semesters from the time of registration.

Master of Taxation Law

Course code: LL58

The Master of Taxation Law program (MTax) is designed to provide specialist education in the complex area of taxation, a key factor in all activities of modern business.

Candidates for this program must complete coursework totalling 48 credit points, over a minimum of five semesters of part-time study. The program may be undertaken in two formats:

- (1) candidates can incorporate three of the core requirements of the Institute of Chartered Accountants for the Professional Year (PY) program; or
- (2) the Master of Taxation Law program can be undertaken by those who are already lawyers, or members of the ACA or ICA, by substituting additional taxation electives for the PY component.

Admission requirements

The minimum requirements for admission to the Master of Taxation program are:

- a degree with an appropriate major;
- completion of a relevant Graduate Diploma at a credit average level; or
- satisfaction of the admission criteria established by the Institute of Chartered Accountants for their Professional Year, or admission criteria set by the Australian Society of Certified Practising Accountants.

In assessing candidates, account is also taken of their professional standing and experience. The number of places available each year is limited.

Applications are assessed by the Course Coordinator, and other UTS staff cannot speculate on an applicant's likelihood of success.

Course structure

A typical Master of Taxation Law program may be:

Incorporating the PY options

Year 1

Semester 1

77796	Taxation of Partnerships and Trusts	6cp
22810	Accounting Module 1 (PY)	6cp

Semester 2

22812	Accounting Module 2 (PY)	6cp
79762	International Taxation 1	6cp

Year 2**Semester 1**

79811 Taxation Module (PY) 6cp

Semester 2

79718 Advanced Taxation 6cp

79701 Stamp Duties 6cp

Year 3**Semester 1**

79702 Land Tax and Payroll Tax 6cp

Without incorporating the PY options**Year 1****Semester 1**

79760 Applied Legal Research 6cp

79718 Advanced Taxation 6cp

Semester 2

79701 Stamp Duties 6cp

77767 Tax Administration 6cp

Year 2**Semester 1**

79763 Contemporary Issues in Tax 6cp

79762 International Taxation 1 6cp

Semester 2

79706 Customs Duties/Levies 6cp

Year 3**Semester 1**

79702 Land Tax and Payroll Tax 6cp

Awarding of Honours

To qualify for Honours in the MTax degree, candidates must attain a minimum average subject mark of 75 per cent **and** completed 79764 Taxation Project.

Electives

Master of Taxation candidates will undertake a combination of the following subjects totalling 48 credit points, depending on their interests and relevant experience:

22810	Accounting Module 1 (PY) ¹	6cp
22812	Accounting Module 2 (PY) ¹	6cp
79718	Advanced Taxation	6cp
79760	Applied Legal Research	6cp
22760	Applied Research Skills ¹	6cp
77719	Capital Gains Tax	12cp
77767	Tax Administration	6cp
22751	Corporate Accounting Issues ¹	6cp
79706	Customs Duties/Levies	6cp
22730	Advanced Audit and Computer Security ¹	6cp
79762	International Taxation 1	6cp
79707	International Taxation 2	6cp
79702	Land Tax and Payroll Tax	6cp
79701	Stamp Duties	6cp
77755	Superannuation Law	6cp
79763	Contemporary Issues in Taxation	6cp
79811	Taxation Module (PY)	6cp
79792	Taxation Paper (1 semester)	6cp
77796	Taxation of Partnerships and Trusts	6cp
79764	Taxation Project (2 semesters)	12cp

Brief descriptions of the subjects listed are given in this handbook under 'Subject descriptions'. Detailed subject descriptions are available from the Administrative Secretary (Postgraduate).

In addition to these subjects, candidates may, with the approval of the Course Coordinator, choose appropriate subjects offered within the LLM/SJD programs (see the subject listing at the end of this handbook). Written application to undertake options from the LLM/SJD programs must be made to the Course Coordinator before enrolment.

¹ These electives are offered by the Faculty of Business.

PRACTICAL LEGAL TRAINING COURSES (PROFESSIONAL PROGRAM)

Admission by the Supreme Court of NSW to practise as either a solicitor or barrister is based upon the successful completion of an undergraduate law degree (or similar qualification e.g. LPAB) and an accredited course of Practical Legal Training (PLT). To this end, the Faculty has modelled its practical legal training courses upon the Law Society's Professional Program, and in particular the Law Society's prescription for two stages of practical training and work experience. The UTS courses have been approved by the Legal Practitioners Admission Board of the Supreme Court of NSW.

Students are provided with written materials and access to computerised resources (including CD-ROM and online resources) in specially-built student accommodation.

Courses of PLT, like any clinically-based education, are intensive and require a considerable commitment from students. The subjects are more demanding, in terms of attendance, than regular undergraduate or postgraduate Law subjects. Apart from the clinical aspects, this is mainly due to the fact that many activities are interactive between teaching staff and students (e.g. practice courts, simulated practice transactions and skills exercises).

The UTS Faculty of Law Professional Program is offered in two consecutive stages: the Graduate Certificate in Legal Practice (GCLP) (which is also available as the legal practice major in the LLB program); and the Graduate Certificate in Continuing Legal Practice (GCCLP).

The Faculty of Law is currently looking at changes to the Professional Program. Please contact the Faculty for further information with regard to the proposed changes.

Graduate Certificate in Legal Practice (Stage I)

Course codes: LL70 (HECS), LL72 (PG fees)

Admission requirements

Candidates must have completed an LLB or have the LPAB qualification.

Course structure

Stage 1 of the Professional Program requires students to successfully complete the following subjects:

75400	Legal Skills and Advocacy	6cp
75401	Litigation	4cp
75402	Property Transactions	4cp
75403	Commercial and Estate Practice	4cp
75404	Legal Accounting and Professional Responsibility	6cp

Attendance

This course is offered in full-time mode comprising one semester of 15 weeks and in part-time mode comprising three semesters of equivalent study and attendance.

Graduate Certificate in Continuing Legal Practice (Stage 2)

Course codes: LL71 (HECS), LL73 (PG fees)

Admission requirements

Candidates in the Graduate Certificate in Continuing Legal Practice (GCCLP) must have completed an LLB or have the LPAB qualification, and have completed the GCLP (Stage 1 of the Professional Program) or its equivalent. Candidates must also have completed 24 weeks of approved work experience.

Course structure

The Graduate Certificate in Continuing Legal Practice requires students to successfully complete the following subjects:

75405	Advanced Legal Accounting	2cp
75406	Professional Conduct	1cp
75407	Work Management	4cp
75408	Advanced Legal Drafting	2cp
75409	In Practice	1cp
75410	Negotiation Skills	2cp
75411	Practical Experience	0cp

Attendance

This course is offered in one semester comprising 60 hours of intensive instruction. The subjects are delivered by a mix of lectures, seminars, workshops and independent research.

Graduate Diploma in Australian Law

Course code: LL57

The Graduate Diploma in Australian Law (GradDipAustLaw) is designed to permit lawyers from common law jurisdictions to satisfy their academic requirements for admission as a legal practitioner of the Supreme Court of NSW.

Further, candidates may also be required to undertake the Graduate Certificate in Legal Practice and the Graduate Certificate in Continuing Legal Practice in order to satisfy the requirements for admission.

Applicants should contact the Legal Qualifications Committee of the Supreme Court of NSW to determine the subjects they are required to complete to be eligible for admission to practise in NSW **before** lodging their application.

Admission requirements

Candidates for the Graduate Diploma must have a Bachelor's degree in Law, or be admitted to practise as a solicitor or barrister in a common law jurisdiction. (This course is not appropriate for candidates who are already admitted to practise in NSW.)

Applicants must also satisfy the English language proficiency requirements of the University, which requires international candidates to have a minimum International English Language Testing System (IELTS) score of 6.5 or its equivalent before enrolling in postgraduate studies. For further details contact the International Programs Office at the UTS postal address.

Attendance

The Graduate Diploma may be undertaken on either a full-time or part-time basis. (Overseas students can only study on a full-time basis under current Australian regulations.) The program requires the completion of subjects totalling a minimum of 48 credit points. Candidates will normally need to study over two or three semesters, depending upon timetabling.

A program of undergraduate subjects is scheduled for individual students. Timetable clashes may result in the program of study extending beyond two semesters.

Minimum enrolment period

The Graduate Diploma requires a **minimum** of one semester of study for a full-time student, and two semesters of study for a part-time student.

Course structure

A minimum program for an overseas lawyer seeking admission in NSW may be:

- Administrative Law
- Real Property
- Federal Constitutional Law
- Legal Accounting and Professional Responsibility

However, each candidate's program may vary, depending on the number of subjects he or she is required to take in order to be admitted to practise in NSW.

Master of Comparative Law

Course code: LL63

The Faculty of Law recognises that the traditional format of a common law LL.M may not be appropriate for candidates from civil law countries. Accordingly, the Faculty offers graduate programs specifically designed for the needs of civil lawyers who wish to gain an understanding of the research skills, methodologies, general concepts and doctrines of the common law, particularly those applicable to international and transnational business transactions.

Central to this is a coursework program leading to the award of Master of Comparative Law. This course provides the bridge between the civil law and the common law.

Students in the Master of Comparative Law (MCL) program complete the coursework requirements of the Graduate Certificate in Comparative Law and then select any approved graduate subjects so that the total number of additional credit points taken is 36.

Admission requirements

Applicants for the MCL must hold a legal qualification from a country with a civil law, or mixed civil and common law, legal system, and have completed the requirements for the Graduate Certificate in Comparative Law.

Applicants must also satisfy the English language proficiency requirements of the University, which requires international candidates to have a minimum International English Language Testing System (IELTS) score of 6.5 or its equivalent before enrolling in postgraduate studies.

For further details contact the International Programs Office at the UTS postal address.

Attendance

The program is offered over one year of full-time attendance. Due to student visa restrictions, international candidates are required to enrol on a full-time basis only. Candidates may also choose subjects offered in the Intensive programs.

Course structure

Candidates are required to complete subjects totalling 48 credit points chosen from postgraduate subjects offered by the Faculty of Law and approved by the Director of Postgraduate Programs, including (and normally beginning with) the subject 77799 Advanced Comparative Law for Civil Lawyers and a capstone subject: Comparative Law Research Project. Students may, with the approval of the Director, take subjects from other law schools.

Assessment

The assessment for each subject may include the following: written papers; presentation of papers; defence of written papers; and written and/or oral examinations prescribed in writing for each subject by the Director of Postgraduate Program, having regard to the student's experience, legal culture and preferences.

Graduate Certificate in Comparative Law

Course code: LL56

The Faculty of Law recognises that the traditional format of a common law LLM or the MCL may not be appropriate for candidates from civil law countries. Accordingly, the Faculty offers graduate programs for lawyers from countries with civil law, or mixed civil and common law, legal systems. These programs are specifically designed for the needs of civil lawyers who wish to gain an understanding of the research skills, methodologies, general concepts and doctrines of the common law, particularly those applicable to international and transnational business transactions.

Central to this is a coursework program leading to the award of the Graduate Certificate in Comparative Law. This is an intensive five- to seven-week course which provides a bridge between civil law and common law.

Course structure

Graduate Certificate candidates complete 77742 Advanced Comparative Law – The Common Law. The topics covered in this subject include the following: sources of the common law; the development of the common law in England and its reception in Australia; courts and lawyers in Australia; law-finding in the common law; contract law in the common law; Australian public law; and aspects of the law regulating business transactions in Australia. Four principal areas are addressed:

- Legal Technique in the Common Law
- Comparative Law Research and Analysis
- Introduction to Business Law
- Selected Issues in International and Transnational Law

This subject may also include visits to the courts and to law firms.

Admission requirements

Applicants for the Graduate Certificate must hold a legal qualification from a country with a civil law, or mixed civil and common law, legal system. (This course is not appropriate for candidates with common law qualifications, or those who are admitted to practise in a common law jurisdiction.)

Applicants must also satisfy the English language proficiency requirements of the University, which requires international candidates to have a minimum International English Language Testing System (IELTS) score of 6.5 or equivalent before enrolling in postgraduate studies. For further details contact the International Programs Office at the UTS postal address.

Attendance

The Graduate Certificate is normally offered in an intensive tuition mode, over approximately five to seven weeks of full-time attendance in the Summer semester (January) and the July Intensive program. Students then complete their written assessment.

After successfully completing the subject Advanced Comparative Law, candidates are eligible to graduate with the Graduate Certificate in Comparative Law. Alternatively, candidates may apply to transfer into the LLM program with advanced standing, or to transfer into the Master of Comparative Law (see above).

Assessment

Assessment for the Graduate Certificate is based on class participation and an essay of approximately 5,000 words on a topic of comparative law.

Transfer to the LLM or MCL program

Candidates who have successfully completed the Graduate Certificate program may, subject to the approval of the Course Coordinator, apply to transfer into the LLM or MCL programs. Transfer applicants must satisfy the Faculty's entry requirements for LLM or MCL candidates.

Candidates who are permitted to transfer to the LLM or MCL programs are not awarded the Graduate Certificate. However, credit is given for the coursework completed towards the Graduate Certificate program as follows:

- (a) Candidates who elect to transfer into the LLM (by thesis) program after successfully completing all the assessment requirements for the Graduate Certificate program submit a reduced thesis of approximately 30,000 words.

Final approval for the admission of candidates and approval of topics resides with the University Graduate School Board.

- (b) Candidates who transfer into the LLM (by coursework) program after successful completion of all of the requirements for the Graduate Certificate are credited with 12 credit points of coursework (25 per cent of the total course requirement). LLM (by coursework) candidates will choose their program from the range of subjects offered within the LLM/SJD program. For more information, refer to the 'Subject descriptions' section in this handbook.

Attendance in Sydney is required for the LLM (by coursework). However, by choosing subjects offered within the Intensive programs it is possible to minimise the period of attendance required.

- (c) Candidates who elect to transfer into the Master of Comparative Law program after successful completion of all requirements for the Graduate Certificate are credited with 12 credit points of coursework (25 per cent of the total course requirement). MCL candidates will choose their program from the range of approved graduate subjects offered by the Faculty.

Master of Legal Studies

Course code: LL68

The Faculty of Law recognises that there are a number of non-lawyers who wish to undertake legal study in order to function effectively in their chosen profession. Accordingly, the Faculty offers this program which provides candidates with a sound theoretical background as well as the practical skills to be able to identify the legal ramifications of issues that they may encounter in their professional capacity. This graduate program has been specifically designed for non-lawyers who wish to have a more detailed understanding of the legal issues raised in their specific area of practice or interest.

The Master of Legal Studies is **not** a professional legal qualification.

Admission requirements

Applicants for this degree should hold an undergraduate degree from an Australian university or an equivalent tertiary qualification. Applicants who have not gained the requisite tertiary qualifications may be admitted if they can demonstrate equivalent work experience and the ability to undertake research at an advanced level.

Attendance

This program will be offered on both a part-time and full-time basis and is expected to be completed over one-and-a-half years on a full-time basis or its equivalent.

Course structure

The course is structured first to provide candidates with a general appreciation of the Australian legal system and, secondly, to allow candidates to select an area of speciality and undertake a major in one of five areas. In the first semester of enrolment, all candidates will undertake seminars in Advanced Legal Research and Legal Process.

Candidates must complete 62 credit points for the Master of Legal Studies:

77700	Advanced Legal Research	2cp
72100	Legal Process ¹ ; plus Subjects chosen from the Faculty's graduate and postgraduate subjects	12cp 36cp
77800	Research Project (MLS)	12cp

¹ Candidates who have undertaken equivalent study may be exempted, and will take another subject or subjects.

Candidates may either choose electives to complete a major or choose any combination of electives. Majors in the following six specific areas are offered:

- Commercial Law
- Dispute Resolution
- Industrial Law
- Intellectual and Industrial Property Law
- International Law
- Australian Indigenous Legal Studies

Brief descriptions of the subjects offered in the program are given in this handbook in the 'Subject descriptions' section detailed. Detailed subject descriptions are available from the Administrative Secretary (Postgraduate). The availability of subjects and majors may vary depending upon demand and the resources of the Faculty of Law.

A typical Industrial and Intellectual Property Law major in the part-time MLS program may be:

Year 1

Semester 1

72100	Legal Process	12cp
77700	Advanced Legal Research	2cp

Semester 2

77815	Patent Law of Australia (LS) (two-semester subject)	6cp
77816	Design Law (LS) (two-semester subject)	6cp

Year 2**Semester 1**

77815	Patent Law of Australia (LS) (cont.)	6cp
77816	Design Law (LS) (cont.)	6cp
77817	Trademarks Law of Australia (LS) (two-semester subject)	6cp

Semester 2

77817	Trademarks Law of Australia (LS) (cont.)	6cp
77800	MLS Research Project – (two-semester subject)	6cp

Year 3

77800	MLS Research Project (cont.)	6cp
-------	------------------------------	-----

Awarding of Honours

To qualify for Honours in the MLS, candidates must attain an average subject mark of 75 per cent.

Graduate Diploma in Legal Studies**Course code: LL67**

The Graduate Diploma in Legal Studies (GradDipLS) is not a professional legal qualification. It is a course designed for non-lawyers who wish to augment their current professional practice with a knowledge of legal issues which arise in their field of practice or interest.

Admission requirements

Applicants for this degree should hold an undergraduate degree from an Australian university or an equivalent tertiary qualification. Applicants who have not gained the requisite tertiary qualifications may be admitted if they can demonstrate equivalent work experience and the ability to undertake research at an advanced level.

Attendance

This program will be offered on both a part-time and full-time basis and is expected to be completed over one year on a full-time basis or its equivalent.

Course structure

The course is structured to first provide candidates with a general appreciation of the Australian legal system and, secondly, to allow students to select an area of specialty and undertake a major in one of six areas. In addition, all candidates will undertake seminars in Advanced Legal Research in their first year of study.

Candidates must complete 50 credit points for the Graduate Diploma in Legal Studies:

77700	Advanced Legal Research	2cp
72100	Legal Process ¹ ; plus Subjects chosen from the Faculty's graduate and postgraduate subjects	12cp 36cp

¹ Students who have undertaken equivalent study may be exempted, and will take another subject or subjects.

Majors in the following six specific areas are offered:

- Commercial Law
- Dispute Resolution
- Industrial Law
- Intellectual and Industrial Property Law
- International Law
- Australian Indigenous Legal Studies

Brief descriptions of the subjects offered in the program are given in this handbook in the 'Subject descriptions' section. The availability of subjects and majors may vary depending upon demand and the resources of the Faculty of Law.

A typical Commercial Law major in the part-time (GradDipLS) program may be:

Year 1**Semester 1**

72100	Legal Process	12cp
77700	Advanced Legal Research	2cp

Semester 2

79703	Legal Aspects of Contracts Administration	6cp
79733	Companies and Securities Law	6cp

Year 2**Semester 1**

79763	Contemporary Issues in Tax	6cp
77821	Banking Law (LS) (two-semester subject)	6cp

Semester 2

77821	Banking Law (LS) (cont.)	6cp
77813	Corporate Insolvency and Restructuring (LS)	6cp

Graduate Diploma in Law for Secondary Teachers

Course code: LL64

The Graduate Diploma in Law for Secondary Teachers (GradDipLaw) aims to prepare secondary school and TAFE teachers for teaching the HSC two- and three-unit Legal Studies courses.

Admission requirements

The Graduate Diploma is directed towards all qualified teachers teaching, or intending to teach, Legal Studies to secondary school or TAFE students. There are no other prerequisites for admission.

Attendance

The Graduate Diploma course is offered on a part-time basis and involves the equivalent of 240 hours of instruction contact. It is intended to be completed over two years. Candidates must complete a total of 48 credit points.

Course structure

Candidates must complete the following four core subjects:

72100	Legal Process	12cp
77847	Law in Context	12cp
77845	International Law, the Environment and Technological Change	12cp
77846	World Order and Indigenous Peoples	12cp

Graduate Certificate in Law for Secondary Teachers

Course code: LL66

The Graduate Certificate in Law for Secondary Teachers aims to prepare secondary school and TAFE teachers for teaching the HSC two-unit Legal Studies course. The course requires the completion of subjects totalling 24 credit points.

Admission requirements

Entry to the course will be available to all qualified teachers who are teaching, or intending to teach, Legal Studies to secondary school or TAFE students. There are no other prerequisites for admission.

Attendance

The Graduate Certificate course is offered on a part-time basis and will involve the equivalent of 120 hours of instruction contact. It is intended to be completed over one year. Candidates must complete a total of 24 credit points.

Assessment

Components of the assessment for the certificate may include a combination of assignments and essays, class presentations and examinations.

Course structure

Candidates must complete the following two core subjects:

72100	Legal Process	12cp
77847	Law in Context	12cp

POSTGRADUATE SUPPLY PROGRAMS

The following postgraduate Law subjects are available to students in other faculties. All inquiries should be directed to the Law Faculty Postgraduate Programs office.

As an undergraduate law qualification is **not** a prerequisite for these subjects (though background knowledge/experience is assumed for most subjects – refer to subject descriptions for prerequisites), they are ideal for persons who have not completed a first degree in Law who wish to extend their knowledge in particular areas of the law.

The following are approved subjects. However not all subjects are offered every semester.

77700	Advanced Legal Research	2cp	77811	Deceptive Trade Practices and Product Liability (LS)	12cp
77717	International Commercial Dispute Resolution	12cp	77812	Restrictive Trade Practices (LS)	12cp
77719	Capital Gains Tax	12cp	77813	Corporate Insolvency and Restructuring (LS)	6cp
77735	Dispute Resolution	12cp	77814	International Commercial Arbitration (LS)	6cp
77745	Negotiation	6cp	77815	Patent Law of Australia (LS)	12cp
77746	Advanced Mediation	6cp	77816	Design Law (LS)	12cp
77748	Victim–Offender Dispute Resolution	6cp	77817	Trademarks Law of Australia (LS)	12cp
77749	Construction Industry Dispute Resolution	6cp	77818	Franchising Law (LS)	6cp
77752	Commercial Arbitration (Domestic)	6cp	77819	Copyright Law (LS)	12cp
77760	Family Dispute Resolution	6cp	77820	Corporations, Finance and Securities (LS)	12cp
77761	Dispute Resolution in Commerce	6cp	77821	Banking Law (LS)	12cp
77762	Industrial Dispute Resolution	6cp	77822	International Banking and Finance Law (LS)	12cp
77763	Community Dispute Resolution	6cp	77823	Advanced Corporate Insolvency and Restructuring (LS)	6cp
77764	Environmental Dispute Resolution	6cp	77824	European Union Law (LS)	12cp
77765	Court-based Dispute Resolution	6cp	77825	Advanced International Economic Law (LS)	6cp
77767	Tax Administration	6cp	77826	European Union Anti-Trust Law (LS)	6cp
77783	International Commercial Dispute Resolution (S)	6cp	77827	Economic Law in Eastern Europe (LS)	6cp
77792	Crisis Negotiation	6cp	77828	Private International Law (LS)	12cp
77801	International Trade Law (LS)	12cp	77829	Advanced European Union Law (LS)	6cp
77802	International Economic Law (LS)	6cp	77830	Maritime Law (LS)	12cp
77803	Current Problems of Public International Law (LS)	6cp	77831	Air Law (LS)	12cp
77804	International Business Transactions (LS)	6cp	77832	Admiralty Law (LS)	6cp
77805	Chinese Trade and Investment Law (LS)	6cp	77833	Carriage of Goods by Sea (LS)	6cp
77806	Chinese Law and Legal Systems (LS)	6cp	77834	Advanced Administrative Law (LS)	12cp
77807	Economic Law in the People's Republic of China (LS)	6cp	77835	Planning and Development Law 1 (LS)	6cp
77808	Indonesian Trade and Investment Law (LS)	6cp	77836	Planning and Development Law 2: Pollution Control (LS)	6cp
77809	International Monetary Law (LS)	6cp	77837	Tax Procedures, Sales Tax and Stamp Duties (LS)	12cp
			77838	Capital Gains Tax (LS)	12cp
			77839	Superannuation Law (LS)	6cp
			77840	Tax Administration (LS)	6cp
			77841	Advanced Constitutional Law (LS)	12cp
			77845	International Law, the Environment and Technological Change	12cp
			77846	World Order and Indigenous Peoples	12cp
			77847	Law in Context	12cp
			77850	Psychology and Dispute Resolution	6cp
			77851	Law and Medicine	6cp
			77852	Current Issues in Corporate Law (LS)	6cp
			77853	Advanced Computerised Legal Research (LS)	6cp
			77854	Advanced Media Law: Libel Law and Privacy (LS)	6cp
			77855	Law of Futures and Derivatives (LS)	6cp
			77856	Private International Air Law (LS)	6cp

77858	Law of Prescribed Interests and Collective Investments (S)	6cp
77859	Computer Law (LS)	6cp
77861	International Business Arbitration: Chinese Perspective (LS)	6cp
77862	Indigenous Context of Australian Law	6cp
77863	Indigenous Dispute Resolution	6cp
77864	Indigenous Land Rights – A Comparative and International Perspective	6cp
77865	Introduction to Taxation Law	6cp
77866	Taxation of Partnerships and Trusts (LS)	6cp

The availability of subjects may vary depending upon demand and the resources of the Law Faculty.

Brief descriptions of the subjects listed are given in this handbook under 'Subject descriptions'. Detailed subject descriptions are available from the Administrative Secretary (Postgraduate). Enrolment inquiries should be directed to the home faculty.

EXTERNAL AWARD STUDY

Students who are enrolled in a postgraduate course leading to an award at another tertiary institution may apply to undertake subjects with the Faculty of Law that will count towards that award.

Admission is subject to the joint approval of both institutions and the availability of places.

Brief descriptions of the subjects offered by the Faculty of Law are outlined in this handbook under 'Subject descriptions'. Detailed descriptions are available from the Administrative Secretary (Postgraduate) if required. As the number of subjects offered in any year is limited, applicants should confirm the timetable for the forthcoming semester with the Faculty of Law before submitting an application.

Admission requirements

Applicants must be enrolled in an equivalent degree at their home institution.

Please note that undergraduate students will not normally be permitted to enrol in postgraduate subjects offered by the Faculty of Law.

Application procedures

Applicants should complete an External Award Study – Application for Admission form. This form is available from the UTS Non-Award Studies Officer or the UTS Information Service.

Completed applications, including a curriculum vitae and certified copies of all required documents, should be sent to:

UTS External Award Studies
Admissions Branch
University of Technology, Sydney
PO Box 123
Broadway, NSW 2007
Telephone: 9514 1559

External award applicants must also obtain a letter of authority from their university's Registrar, which should be forwarded to the above address.

The closing dates for applications are as follows:

Summer program – 31 October

Autumn semester – 30 December

Spring semester – 30 June

EXTENSION (NON-AWARD) STUDY

Extension study in postgraduate Law allows candidates who do not wish to undertake a full degree program the opportunity to learn or upgrade their knowledge in a selection of subjects.

Extension students undertake subjects offered in the Faculty's degree programs. Brief descriptions of the subjects offered by the Faculty of Law are outlined in this handbook under 'Subject descriptions'. Detailed descriptions are available from the Administrative Secretary (Postgraduate) if required. As the number of subjects offered in any year is limited, applicants should confirm the timetable for the forthcoming semester with the Faculty of Law before submitting an application.

In addition, extension study may entitle students to Mandatory Continuing Legal Education points. Contact the Law Society of NSW for further details.

Admission requirements

Applicants are expected to have achieved an appropriate level of knowledge in relation to the area to be studied, or to demonstrate the ability to successfully undertake postgraduate study.

Application procedures

Applicants should complete an Extension (Non-Award) Study Application form, available from the Non-Award Studies Officer or the UTS Information Service.

Completed applications, including a brief resumé, and proof of age, Australian permanent residency and educational status, should be sent to:

Non-Award Studies Officer
Admissions Branch
University of Technology, Sydney
PO Box 123
Broadway, NSW 2007
Telephone: 9514 1559

The closing dates for applications are as follows:

Summer program – 31 October

Autumn semester – 30 December

Spring semester – 30 June

Fees

Fees are paid at registration where a UTS ID card will be issued for use of the Library and other student facilities. Fees are non-refundable after the commencement of semester. However, where a student is forced to withdraw due to illness or disability, a letter requesting reimbursement (supported with appropriate verification) should be submitted to the Non-Award Studies Officer for consideration.

Subject descriptions

UNDERGRADUATE SUBJECTS

The undergraduate subject descriptions shown below indicate the subject code and name, and number of credit points for the subject (e.g. 3cp). Also shown are the prerequisites or corequisites if any, and a brief outline of the content and texts. Unless specified, the latest editions are recommended.

Prerequisites are subjects that must be completed before taking the subject to which they refer. Corequisites may be completed before or else must be taken concurrently with the subject to which they refer.

70105

Legal Research

4cp; prerequisite: nil

This subject aims to familiarise students with the basic tools available to engage in legal research. It includes an introduction to various paper-based resources (citations, digests etc.).

Students are also introduced to the use of computerised systems as an aid to legal research. The major CD-ROM based products (such as *Info-One LAW PAC*, *diskROM/Computer Law Services*, *Austrom/AGIS* and *Wilson Index to Legal Periodicals*) and online systems (such as *Info-One* and *Scale*) are dealt with. The course will also include a brief introduction to legal resources on the Internet.

Text

Watt R J, *Concise Legal Research*, Federation Press

70113

Legal Process and History

10cp; prerequisite: nil

This subject aims to introduce students to, and to provide students with, a sound working knowledge of the Australian legal and constitutional environment. The subject also aims to equip students with certain legal skills – in particular, the skills of case analysis, statutory interpretation, legal problem solving and critical analysis – which are essential to the study and practice of the law. Students will

be asked to consider what is law, who makes law, and how and why the law has developed in the way that it has. They will also examine the institutions that make up our legal system – the legislature, the Crown and the executive, the courts and the ‘legal players’ (the judge, the jury and the legal practitioner) – and explore the principles and doctrines that underpin our legal system. Further, they will be asked to consider why our legal system is so different from that of some of our regional neighbours, and to evaluate the strengths and weaknesses of the common law legal system. Valuable insight into the way our legal system operates may be gained through using a historical approach, and this means delving back into English, as well as Australian, legal and constitutional history. Such an approach also facilitates refinement of critical analysis skills. At the end of the subject, students should have a fully developed understanding of the Western legal tradition, the place of common law in that system, and the ramifications of living under a Westminster Parliamentary system as well as a federal system.

Texts and references

Derham D, Maher K F, Waller L, *An Introduction to Law*, Law Book Company, 1991

Morris G et al, *Laying Down the Law*

Parkinson P, *Tradition and Change in Australian Law*

70211

Law of Contract

8cp; prerequisites: 70113 *Legal Process and History*; 70105 *Legal Research*; corequisite: 70217 *Criminal Law*

This subject deals with the legal principles related to when promises are binding, the difficulties arising out of their interpretation, how they may become defeasible, issues relating to their performance, and how they may be discharged. Topics covered include the formation of contracts (agreement, consideration, terms); vitiating factors (capacity, mistake, misrepresentation, illegality, duress, undue influence, unconscionability); discharge by performance and non-performance of contractual

obligations (breach and frustration); and contractual remedies.

Texts and references

Carter J W and Harland D J, *Cases and Materials on Contract Law in Australia*, 2nd edn, 1993

Carter J W and Harland D J, *Contract Law in Australia*, 3rd edn, Butterworths, 1996

Cheshire and Fifoot, *Law of Contract*, 7th Aust. edn, 1997

Greig D and Davis J, *The Law of Contract*, 1987, and Fifth Supplement, Law Book Company, 1993

Hocker and Heffey, *Cases and Materials on Contract*, 7th edn, 1993

70217

Criminal Law

6cp; corequisites: 70113 Legal Process and History; 70105 Legal Research

The subject deals with the substantive criminal law, the doctrines and rules that define the conditions of criminal liability and some aspects of the procedural law. Australian common law doctrine and the *Crimes Act 1900* (NSW) are considered. Topics include the nature of crime; the doctrine of *mens rea* and *actus reus*; presumption of innocence; offences against the person; property offences; strict, vicarious and corporate liability; complicity; criminal defences; criminal investigation and procedure; and drug law.

Texts and references

Crimes Act 1900 (NSW)

Fisse B (ed.), *Howard's Criminal Law*, 5th edn, Law Book Company, 1990

Gillies P, *Criminal Law*, 3rd edn, Law Book Company, 1993

Helipern D and Yeo S, *Cases on Criminal Law*, Law Book Company, 1995

Waller L and Williams C R, *Criminal Law: Text and Cases*, 8th edn, Butterworths

Brown D, Farrier D and et al, *Criminal Law*, 2nd edn, Federation Press, 1996

70311

Law of Tort

8cp; prerequisites: 70113 Legal Process and History; 70105 Legal Research; 70217 Criminal Law

This subject discusses the functions and aims of the tort. It then examines the nature of tortious liability in the light of a selection of

specific torts, namely, trespass to the person, goods and land; the action on the case for wilful injuries; conversion; negligence; nuisance; and defamation. Reference is also made to defences, vicarious liability and contribution between tortfeasors.

Attention is drawn to the relevance of the type of conduct complained of (intentional, reckless, careless); the nature of the various interests protected (personal security, chattels, land, reputation, economic interests, domestic relations); the adaptability of tort law to changing needs and values of society (thus the introduction, dominance and current perceived limitations of the fault concept); and the element of policy expressed or implied in judicial decisions.

Texts and references

Balkin R P and Davis J L R, *Law of Torts*, Butterworths, 1996

Fleming J G, *The Law of Torts*, 8th edn, Law Book Company

Trindade F and Cane P, *The Law of Torts in Australia*, 2nd edn, Oxford University Press

Gardiner D, *Outline of Torts*, Butterworths

Luntz H and Hambly A D, *Torts: Cases and Commentary*, 3rd edn, Butterworths, 1995

Morison W L and Sappideen C, *Torts, Commentary and Materials*, 8th edn, Law Book Company

70317

Real Property

8cp; prerequisites: 70211 Law of Contract; 70311 Law of Tort; 70616 Federal Constitutional Law

Topics covered include agreements for sale of land; time for completion; Torrens title and priorities; old system, possessory, qualified and limited title; fixtures; trespass to land; co-ownership; easements; covenants; mortgages; and leases

Texts and references

Butt, *Land Law*, 3rd edn, Law Book Company
Conveyancing Act 1919 (NSW)

Land and Skapinker, *Sale of Land*, 3rd edn, Longmans

Real Property Act 1900 (NSW)

Sappideen C and Ors, *Cases and Materials on Real Property*, 3rd edn, Law Book Company

70318

Personal Property

4cp; prerequisite: 70211 Law of Contract

Topics covered include classifications of personal property, choses in action and choses in possession; acquisition of title to goods; law of bailment; insurance; securities interests in chattels; and law of negotiable instruments, with particular reference to cheques.

Texts and references

Helmore B A, *Commercial Law and Personal Property in NSW*, 10th edn, by Carter J W et al, Law Book Company, 1992

70417

Corporate Law

8cp; prerequisites: 70317 Real Property; 70617 Administrative Law; corequisite: 70516 Equity and Trusts

The response of the law to the activities of business entities is dealt with in this subject. Although the emphasis is on corporations, there will be a brief discussion of the manner in which non-corporate entities including partnerships are regulated. The study of corporations law will include an overview of the historical developments, the current method of regulation and the proposals for reform.

Texts and references

Cassidy J, *Concise Corporations Law*, Federation Press, 1995

Corkery J F, *Directors' Powers and Duties*, Longman, 1987

Fletcher K, *The Law of Partnership in Australia and New Zealand*, Law Book Company

Tomasic R and Bottomley S, *Corporations Law in Australia*, Federation Press, 1995

70516

Equity and Trusts

8cp; prerequisites: 70317 Real Property; 70318 Personal Property

Topics include the nature of equity; equitable estates and interests; equitable priorities; assignments in equity; fiduciary obligations; confidential information; the nature of trusts; express trusts; charitable trusts; implied trusts; constructive trusts; powers, rights and duties of trustees; rights of beneficiaries.

Texts and references

Chalmers D, *Introduction to Trusts*, Law Book Company, 1988

Evans M B, *Outline of Equity and Trusts*, Butterworths, 1988

Ford H A J and Lee W A, *Principles of the Law of Trusts*, 2nd edn, Law Book Company, 1990

Heydon J D, Gummow W M C and Austin R P, *Cases and Materials on Equity and Trusts*, 3rd edn, Butterworths, 1989

Meagher R P and Gummow W M, *Jacobs' Law of Trusts in Australia*, 5th edn, Butterworths, 1986

Meagher R P, Gummow W M C and Lehane J R F, *Equity: Doctrines and Remedies*, 3rd edn, Butterworths, 1992

70616

Federal Constitutional Law

8cp; prerequisites: 70113 Legal Process and History; 70105 Legal Research; 70217 Criminal Law

This subject examines the effect of the Australian Constitution on the legal and fiscal relationship of the Commonwealth and States. In order that students develop an understanding of the techniques of judicial review in the constitutional context, a range of powers given to the Commonwealth is examined. These include trade and commerce, corporations, taxation, and external affairs. Other areas examined are explicit and implicit restrictions of power, the questions of inconsistency and intergovernmental relations. The general role of the High Court in Australian constitutional law is considered along with the Separation of Powers Doctrine as it relates to the independence of the Judiciary.

Texts and references

Booker K, Glass A and Watt R, *An Introduction to Australian Federal Constitutional Law*, Butterworths, 1994

Blackshield T, Williams G and Fitzgerald B, *Australian Constitutional Law Theory: Commentary and Materials*, Federation Press, 1996

70617

Administrative Law

8cp; prerequisites: 70317 Real Property; 70616 Federal Constitutional Law

This subject deals with the supervision of the executive arm of government by the courts and by other statutory mechanisms. Topics include the grounds of review of administrative decisions, in particular natural justice; *ultra vires*; jurisdictional error and error of law;

remedies available at common law upon judicial review, including the prerogative writs and equitable remedies; judicial review under the *Administrative Decision (Judicial Review) Act 1976* (Cth); a review of Commonwealth decisions under the *Administrative Appeals Tribunal Act 1976* (Cth); and the role and function of the Ombudsman. If time permits, freedom of information and privacy legislation will also be touched upon, and the role of the Independent Commission Against Corruption (ICAC).

Texts

Douglas R and Jones M, *Administrative Law: Cases and Materials*, 2nd edn, Federation Press, 1996

71005

Practice and Procedure

4cp; prerequisite: 70516 *Equity and Trusts*

Practice and Procedure is a core subject that develops the students' understanding of the process of litigation from the commencement of proceedings through to the final hearings. Topics include statements of claim in contracts and torts; defence, cross claims and replies; equitable proceedings; particulars; discovery, inspection and interrogatories; notice of motion; drafting affidavits; subpoenas; and advocacy skills.

71116

Remedies

6cp; prerequisites: 70417 *Corporate Law*; 70516 *Equity and Trusts*

This subject deals with the range of court-ordered remedies available to a plaintiff in civil proceedings. The more common remedies are those administered at either common law or in equity: damages; equitable remedies (declarations, specific performance, injunctions, Anton Pillar orders, account, equitable damages); and statutory and common law remedies for deceptive conduct. Bankruptcy and insolvency will also be considered.

Texts and references

Covell W and Lupton K, *Principles of Remedies*, Butterworths, 1995

Tilbury MJ, *Civil Remedies*, Vols I & II, Butterworths, 1990 and 1993

Noone M and Kercher B, *Remedies: Commentary and Materials*, 2nd edn, Law Book Company, 1993

71216

Law of Evidence

6cp; prerequisites: 70417 *Corporate Law*; 70516 *Equity and Trusts*

This subject deals with adjectival law and the determination of how information may be presented to the court in litigation, when such information will be admissible in evidence, and how the rules of proof are applied. The inclusionary rule of relevance, the various exclusionary rules (such as hearsay, opinion, tendency, coincidence, credibility, character, privilege), and the judicial discretion to exclude will be studied, as well as the incidence of the burden of proof.

Texts and references

Aronson M et al, *Litigation: Evidence and Procedure*, 5th edn, Butterworths, 1995

Australian Law Reform Commission, *Evidence*, ALRC Reports Nos 26 (Interim, two vols, 1985) and 38 (1987)

Brown R, *Documentary Evidence in Australia*, 2nd edn, Law Book Company, 1996

Buzzard J H, May R, Howard M N, *Phillips on Evidence*, 14th edn, Sweet & Maxwell, 1990

Byrne D and Heydon J D, *Cross on Evidence*, 5th Aust. edn, Butterworths, 1996

Byrne D and Heydon J D, *Cross on Evidence*, loose-leaf, Butterworths

Campbell E and Waller L, *Well and Truly Tried: Essays on Evidence*, Law Book Company, 1982

Forbes J R S, *Similar Facts*, Law Book Company, 1987

Gillies P, *Law of Evidence in Australia*, 2nd edn, Legal Books, 1991

Glass H H (ed.), *Seminars on Evidence*, Law Book Company, 1975

Heydon J D, *A Guide to the Evidence Act 1995 (Cth)*, Butterworths, 1995

Ligertwood A, *Australian Evidence*, 2nd edn, Butterworths, 1993

Ligertwood A, *Australian Evidence: Cases and Materials*, Butterworths, 1995

McNicol R, *Law of Privilege*, Law Book Company, 1992

Odgers S, *Uniform Evidence Law*, 2nd edn, Federation Press, 1997

Waight P K and Williams C R, *Evidence: Commentary and Materials*, 4th edn, Law Book Company, 1995

72 SUBJECT DESCRIPTIONS

Wellman F, *The Art of Cross-Examination*, 4th edn, Collier Books, 1936

Wells W A N, *Evidence and Advocacy*, Butterworths, 1988

Wigmore J H, *Evidence in Trials at Common Law*, Boston, 1961

Zariski A (ed.), *Evidence and Procedure in a Federation*, Law Book Company, 1993

72100

Legal Process

12cp; 1 semester; availability GDIP, GCLST, GDLST, GDLS, MLS, SUPPLY

This subject is a prerequisite for all subjects in the Graduate Diploma in Industrial Property. It is designed to give students from non-legal backgrounds a grounding in the principles of legal processes. It deals with the nature of law, the sources of law and the system of law governing NSW as part of the Commonwealth of Australia. Students are instructed in case analysis, the doctrine of precedent, statutory interpretation, legal reasoning and legal research skills. It also introduces the law of torts, property, contracts, trade practices and criminal law. This is a compulsory subject for MLS, GDLS.

75400

Legal Skills and Advocacy

6cp

Legal Skills and Advocacy is one of the five legal practice course subjects which form Stage 1 of the Professional Program.

This subject will include trial process and advocacy (e.g. court etiquette, mentions, bail applications, pleas in mitigation, presenting submissions, presenting evidence and defended hearings), interlocutory applications and motions, writing and drafting, and interviewing and advising. The subject will be assessed by way of written assignments and performance testing (e.g. practice courts).

75401

Litigation

4cp

Litigation is one of the five legal practice course subjects which form Stage 1 of the Professional Program.

This subject will include civil litigation and commercial litigation practice (in the Local, District, Supreme and Federal Courts), criminal law practice, personal injury practice

and specialist practice areas including industrial law, administrative law, family law and environmental law. The subject will be assessed by way of seminar presentations, written assignments (e.g. practice file) and an open book examination.

75402

Property Transactions

4cp

Property Transactions is one of the five legal practice course subjects which form Stage 1 of the Professional Program.

This subject will include domestic conveyancing, commercial conveyancing and leasing, mortgages, finance and securities and revenue regulation. The subject will be assessed by way of seminar presentations, written assignment (e.g. practice file) and an open book examination.

75403

Commercial and Estate Practice

4cp

Commercial and Estate Practice is one of the five legal practice course subjects which form Stage 1 of the Professional Program.

This subject will include commercial planning, commercial transactions, trust and estate planning and probate and estate administration. The subject will be assessed by way of seminar presentations, written assignment (e.g. practice file) and an open book examination.

75404

Legal Accounting and Professional Responsibility

6cp

Legal Accounting and Professional Responsibility is one of the five legal practice course subjects which form Stage 1 of the Professional Program.

This subject will include legal practice book-keeping procedures, trust account regulation and management, professional responsibility, conduct and discipline. The subject will be assessed by way of written assignment, workshop presentation and an open book examination in each component.

75405**Advanced Legal Accounting**

2cp; prerequisite: completion of GCLP (Stage 1 of Professional Program) or equivalent; employment criteria also apply

Advanced Legal Accounting is one of the six continuing Legal Practice Course subjects which for Stage 2 of the Professional Program will include an examination of accounting fundamentals (financial statements, balance sheets and profit and loss accounts), an analysis of financial statements and accounting standards, the use of accounting documents as evidence, and a consideration of the banking, securities and investment environment and the Australian Stock Exchange. The subject will be assessed by way of written assignment and class participation.

75406**Professional Conduct**

1cp; prerequisite: completion of GCLP (Stage 1 of Professional Program) or equivalent; employment criteria also apply

Professional Conduct is one of the six continuing Legal Practice Course subjects which for Stage 2 of the Professional Program will examine the current issues and trends in the legal profession, the concept of collective responsibility, market forces and the supply and cost of legal services, specialist accreditation, national standards and mutual recognition. The subject will be assessed by way of structured activities and class participation.

75407**Work Management**

4cp; prerequisite: completion of GCLP (Stage 1 of Professional Program) or equivalent; employment criteria also apply

Work Management is one of the six continuing Legal Practice Course subjects which for Stage 2 of the Professional Program will examine personal and office management procedures and systems, including techniques for managing workloads and the effective use of modern technology. This subject will also consider client care issues including client analysis, and risk management with a particular emphasis on total quality systems (TQS). The subject will be assessed by way of structured activities, written assignment (reflective journal) and class participation.

75408**Advanced Legal Drafting**

2cp; prerequisite: completion of GCLP (Stage 1 of Professional Program) or equivalent; employment criteria also apply

Advanced Legal Drafting is one of the six continuing Legal Practice Course subjects which for Stage 2 of the Professional Program will provide an advanced level of instruction in basic language skills and drafting strategies with reference to legally related contentious and non-contentious documentation. This subject will also emphasise the use of plain English in a legal context. The subject will be assessed by way of written assignment and class participation.

75409**In Practice**

1cp; prerequisite: completion of GCLP (Stage 1 of Professional Program) or equivalent; employment criteria also apply

In Practice is one of the six continuing Legal Practice Course subjects which for Stage 2 of the Professional Program will consider cultural awareness issues as they impact on legal practice including indigenous cultural values, land rights and heritage protection. This subject will also consider current relevant issues affecting the practice of law. The subject will be assessed by way of structured activities and class participation.

75410**Negotiation Skills**

2cp; prerequisite: completion of GCLP (Stage 1 of Professional Program) or equivalent; employment criteria also apply

Negotiation Skills is one of the six continuing Legal Practice Course subjects which for Stage 2 of the Professional Program will examine the dispute resolution processes currently available in NSW with particular reference to negotiation. This subject will also consider communication and conflict resolution skills, in addition to the gender and cross-cultural issues affecting dispute resolution. The subject will be assessed by way of structured activities, written assignment (negotiation journal); video performance and class participation.

76001**Comparative Law A***6cp; prerequisite: nil*

The subject deals with the comparative method of legal research and examines the growing 'interdependence' and similarity of the civil law, socialist and the common law systems. It consists of two sections.

The first section is concerned with an introduction to the major legal systems in the world. Emphasis will be placed on a study of the development of the Romano-Germanic system of law, the formation of the socialist legal system and the law of the United States of America. These legal systems will be compared with the common law system. Among the topics covered will be a study of the meaning, sources and structure of law in the legal systems under consideration. The second section is devoted to the civil law method. Other topics which will be discussed include the legal profession and legal education in civil law as well as in various countries.

Texts and references

Dadomo C and Farran S, *The French Legal System*, Sweet & Maxwell, 1993

David R and Brierley J E C, *Major Legal Systems in the World Today*, Stevens and Sons

Certoma C L, *The Italian Legal System*, Butterworths, 1985

Foster M, *German Law & Legal System*, Blackstone, 1993

Sheridan and Cameron, *Central and Eastern European Legal System: An Introductory Guide*, Butterworths, London, 1995

Zweigert K and Kotz H, *An Introduction to Comparative Law*, North-Holland Publishing Co., 1997

76003**Comparative Law B***6cp; prerequisite: nil*

The subject exposes students to another legal system. It is designed to introduce students to the reception of legal systems in the countries of South and South-East Asia, with special reference to the reception of English law and Islamic law by these countries.

Texts and references

APEC Secretariat, *Guide to The Investment Regimes of the APEC Member Economies*, 2nd edn, November, 1994, APEC Committee on Trade and Investment (CTI), Singapore 1994

Fyze A A A, *Introduction to Mohammedan Law*, 4th edn, Oxford University Press, 1974

Hooker M B (ed.), *The Laws of South-East Asia, Vol. 1: The Pre Modern Series*, Butterworths Asia, Singapore, 1986

Hooker M B (ed.), *The Laws of South-East Asia, Vol. 2: European Laws in South-East Asia*, Butterworths Asia, Singapore, 1988

International Legal Services Advisory Council, *Legal Services Country Profiles*, Attorney-General's Department, Australia, Canberra, 1995

Laurence J B, *Vietnam, Banking and Finance*, Butterworths Asia, Singapore, 1991

76004**Administration of Criminal Justice***6cp; prerequisite: 70217 Criminal Law*

The subject covers: (a) criminal investigation, covering police interrogation, arrest, detention, search, seizure, remedies against the police, reception of confessional evidence and discretion to exclude evidence; (b) criminal prosecution, covering bail, summary proceedings, committal proceedings, jury trials, discretion to prosecute, indictment, joint trials, pleas, duties of prosecutor, duties of trial judge, course of evidence, verdict, sentencing, criminal compensation, appeals.

Texts and references

Johnson P A, *Criminal Law and Practice*, loose-leaf, Butterworths

Watson R S and Purnell H, *Criminal Law in NSW*, loose-leaf, Law Book Company

76006**Public International Law***6cp; prerequisite: 70616 Federal Constitutional Law*

The following topics are selected for study in this subject, with particular attention being paid to the development of the law through the machinery of the United Nations in its relationship with the state, international organisations and even the individual: the nature, characteristics and function of international law; the sources of international law (including the role and characteristics of the International Court of Justice); the law of treaties; the concept of state sovereignty and domestic jurisdiction; the relationship between international law, municipal law and the individual (including the international protection of human rights); statehood and

sovereignty; personality, rights and duties of states; the recognition of states and governments; state succession; territorial sovereignty of the land and sea (with emphasis on limits); jurisdiction of states (including jurisdictional competence, immunity from jurisdiction, asylum and extradition); immunities and privileges in diplomatic and consular relations; international organisations (especially the United Nations); and armed conflict and settlement of international disputes.

Text

Blay, Piotrowicz and Tsamenyi, *Public International Law in Australia*, Oxford University Press, 1997

76007

Human Rights

6cp; prerequisite: 70616 *Federal Constitutional Law*

The subject covers the establishment and enforcement of human rights, constitutional rights, common law rights, and international protection of human rights. Topics include the following: freedom of speech, assembly and association; women's rights; anti-discrimination law; the rights (including land rights) of Aborigines; and the rights of immigrants and refugees.

Texts and references

Gaze B and Jones M, *Law, Liberty and Australian Democracy*, Law Book Company

O'Neill N and Handley P, *Retreat from Injustice: Human Rights in Australian Law*, Federation Press

Ghandi P R, *Blackstones' International Human Rights Documents*, Blackstone Press, 1995

Bailey P, *Bringing Human Rights to Life*, Federation Press, 1993

76008

Jurisprudence

6cp; prerequisite: 70311 *Law of Tort*

Deals with theoretical questions that are relevant to an understanding of the notion of law (e.g. What is the law of the state? Is there any other command, convention or the like that can also be called 'law'?). It also includes a discussion of different approaches to the study of law (e.g. philosophical, sociological, historical, analytic, international, comparative) to determine its derivation, nature and function, as well as a discussion of the

doctrines and techniques of legal analysis and evaluation. The various approaches are compared and criticised in the context of sociopolitical problems, conflicts and other phenomena. Topics here include causation and the law, sovereignty and the law, legal rights and duties, law and ideology. Their treatment in the common law will be examined. A number of theorists are considered e.g. von Savigny, Austin, de Jouvenel, Dworkin.

In conceptual terms, law is analysed as a logical system (legal), as a part of a composite system (social), and as a specific legal institution (e.g. constitutional law). Constitutionalism will be distinguished from legality, and the problem of political or social revolution addressed (in other words, how can legality be justified *vis-a-vis* the ensuing struggle for sovereignty in the state which is always present in any revolution?).

Texts and references

Dias R W M, *Jurisprudence*, Butterworths, 1985

Douzinas C, Warrington R and McVeigh S, *Postmodern Jurisprudence*, Routledge, 1991

Harris J W, *Law and Legal Science*, Clarendon Press, 1979

Kerruish V, *Jurisprudence as Ideology*, Routledge, 1991

Reisman W M and Schreiber A M, *Jurisprudence, Understanding and Shaping Law*, New Haven Press, 1987

76011

Industrial and Intellectual Property

6cp; prerequisites: 70317 *Real Property*; 70318 *Personal Property*; corequisite: 70516 *Equity and Trusts*

This subject is intended to introduce students to, and provide an understanding of, the ways in which the legal system recognises, protects and regulates the exploitation of exclusive rights in certain intangible industrial and intellectual 'property'. The basic structure of the subject will be as follows:

Confidential information: trade secrets and the problem of know-how, scope of the present law, classification of type of protection, relation to patent system, remedies available.

Patents: history of patents, patentable subject matter, application process, employee's inventions, patent office and third party objections, grounds of invalidity, infringement, licences, assignment, Crown use, patents of addition, extensions.

Designs: subject matter, registration, invalidity, infringement, relationship to the copyright system.

Trademarks and trade names: protection at common law, passing off and s.52 of the *Trade Practices Act 1974*, unfair competition, trademark legislation and its relation to common law protection, right to apply, purpose of registration, distinctiveness, deception and confusion, defensive registration, certification marks, infringement, assignment, registered user agreement, the licensing and exploitation of marks, non-use and use by competitors.

Copyright: history of copyright protection, nature of works and subject matter in which copyright subsists, nature of exclusive rights, ownership, assignment, licensing, infringement.

Texts and references

Australian Industrial and Intellectual Property, loose-leaf, CCH

Blakeney M L and McKeough J, *Intellectual Property: Commentary and Materials*, 2nd edn, Law Book Company, 1992

Lahore J C, *Intellectual Property in Australia: Copyright*, loose-leaf, Butterworths

Lahore J C, Garnsey J J, Dwyer J, Duffy A and Covell W, *Intellectual Property in Australia: Patents, Designs and Trade Marks Law*, loose-leaf, Butterworths

McKeough J and Stewart A, *Intellectual Property in Australia*, Butterworths, 1991

Ricketson S, *Intellectual Property Cases: Materials and Commentary*, Butterworths, 1994

76012

Criminology

6cp; prerequisite: 70217 Criminal Law

This subject explores how crime is socially constructed. A diverse range of criminological issues is considered. These include official and non-official measures of crime; theories of crime; variables of crime (age, sex, ethnicity, socioeconomic status), as well as specific offences (e.g. homicide, white-collar crime, sexual and non-sexual assault and disorderly behaviour). Additionally, methods of controlling crime and preventing crime are reviewed. Readings for this subject are derived from a collection of books, reports, articles and current conference papers.

Texts and references

Students will be provided with detailed reading materials. Other recommended reading includes:

Maguire et al, *Oxford Handbook on Criminology*, Oxford, 1994

Young A, *Imagining Crime*, Sage, 1996

White R, *Crime and Criminology*, OUP, 1996

76014

Law and Computers

6cp; prerequisites: 70105 Legal Research; 70317 Real Property; 70217 Criminal Law

An introduction to computers as they relate to the administration and practice of the law, and to specific areas of the law as they relate to computers. After an analysis of computer concepts and terminology, with basic instruction in the use of personal computers, the subject deals with legal issues raised by computer technology (e.g. computer crime, software copyright and data protection), and the development of computer applications for legal use, with the major focus on leading-edge technologies, such as expert systems and hypertext systems.

Text

Electronic course materials are issued throughout the semester.

76015

Labour Law

6cp; prerequisites: 70211 Law of Contract; 70311 Law of Tort

The subject consists of two parts: individual aspects of the employment relationship; and the formation, foundation and termination of the employment contract. The subject also examines the rights and liabilities of employers and employees under common law principles and legislation including occupational health and safety law, anti-discrimination law and remedies involving reinstatement.

Texts and references

Creighton B et al, *Labour Law Text and Materials*, Law Book Company

Macken J J et al, *Law of Employment*, 4th edn, Law Book Company

McCallum R et al, *Australian Labour Law: Cases and Materials*, Butterworths

76016**Advanced Taxation Law**

6cp; prerequisite: 76212 Revenue Law

This subject builds on the understanding obtained from the completion of the elective 76212 Revenue Law, providing the student interested in a further study of taxation law, a specialised area of legal practice, with the opportunity to pursue that interest. Topics covered include taxation of companies – company formations, distributions, capital gains tax, transfer pricing, value shifting; taxation of trusts – formation, distributions and CGT problems; taxation of partnerships – taxation of partners, CGT problems; international taxation – residence and source, CFCs, FIFs; tax administration – the assessment and appeals processes; tax avoidance and ethics.

Texts and references

Income Tax Assessment Act, 1936

Income Tax Assessment Act, 1997

Butler, *Australian Federal Company Taxation*, Butterworths, 1994

Cooper et al, *Income Taxation Commentary and Materials*, 2nd edn, Law Book Company, 1993

Gates, *Tax Aspects of Corporate Restructuring*, Law Book Company/ATP, 1996

Lehman G and Coleman C, *Taxation Law in Australia*, 4th edn, Law Book Company, 1996

Woellner et al, *Australian Taxation Law*, CCH

76017**Strata Titles and Community Schemes**

6cp; prerequisite: 70317 Real Property

An introduction to the laws and practices regulating strata title developments and the increasing numbers of strata leasehold and community title developments. Topics include overviews of the various schemes (including alternatives to strata, strata leasehold and community title), boundaries, subdivision procedures, local government approval, staged development, common and association property, by-laws and management statements, managing agents, management procedures, disputes, insurance, variation and termination of schemes, strata leasehold lot and common property leases, the role of the

solicitor acting for a developer, vendor, purchaser and mortgagee.

Texts and references

Bugden G F, *Strata Title Management Practice in New South Wales*, CCH

Bugden G F and Allen M G, *New South Wales Strata and Community Titles Law*, loose-leaf, CCH

Moses N J, Tzannes R T and Skapinker D S, *Strata Titles*, Law Book Company

76018**International Economic Law**

6cp; prerequisites: 70317 Real Property; 70318 Personal Property

Because of the vastness of the topic, it is not possible to cover the subject in one semester: it is therefore proposed to deal with certain basic aspects, as well as a number of topics which are particularly pertinent at the time of lecturing. In this introductory topic, the following items will be discussed: sources of law; the present regime; the new economic order; the new world corporate order; the international economic order; the economic union.

Investment: control of the multinational corporation; settlement of international investment disputes.

Finance: The International Monetary Fund; floating currencies; foreign exchange control law and international contracts (Article VII of the IMF); aspects of international fiscal law; European monetary system; sovereign debt problems; Eurocurrency markets.

Trade: the general agreements on tariffs and trade; the World Trade Organisation; protectionism and legal reactions; trading blocs, others; UNCTAD and the GSP; political controls and boycotts; international contracts; uniformity of international trade law; international commodity agreements.

National law and international economic law: sovereign immunity; extraterritorial jurisdiction; subject matter jurisdiction; antitrust law; corrupt practices; securities law; personal jurisdiction; taxation (current problems, pricing, unitary taxation).

Texts and references

There is no single textbook covering the whole field. However the following texts are an excellent introduction:

Lazar L, *Transnational Economic and Monetary Law*, Vols I–VIII, Oceana

Lowenfeld A F, *International Economic Law*, Vols I-VI, Matthew Bender

MacBean A I and Snowden P N, *International Institutions in Trade and Finance*, Allen & Unwin

76022

Law of Insurance

6cp; prerequisites: 70211 *Law of Contract*; 70311 *Law of Tort*; 70516 *Equity and Trusts*

The subject concentrates on a study of the general principles of insurance law, but does not examine in detail the special rules governing each class of insurance contract. After the nature of the contract of insurance is noted, key concepts will be dealt with: insurable interest, indemnity and subrogation, risk, non-disclosure, misrepresentation, conditions, warranties, premium. Subsidiary matters such as assignment of policies, liens and reinsurance will be considered. The role of insurance intermediaries in the formation of contracts of insurance will be examined. The subject thus focuses on the legal rights and liabilities of parties to an insurance contract in the context of common law principles and statutory modification. In addition, consideration will be given to the regulatory framework within which the insurance industry operates in Australia.

Texts and references

Appleman, *Insurance Law and Practice*, loose-leaf, West Publishing Co.

Australian and New Zealand Insurance Reporter, loose-leaf, CCH

Australian Law Reform Commission, *Insurance Agents and Brokers*, Report No. 16, AGPS, 1980

Australian Law Reform Commission, *Insurance Contracts*, Report No. 20, AGPS, 1982

Clarke M A, *The Law of Insurance Contracts*, 2nd edn, Lloyds, 1994

MacGillivray and Parkington, *Insurance Law and Practice*, 8th edn, Sweet & Maxwell, 1988

Sutton K, *Insurance Law in Australia and New Zealand*, 2nd edn, Law Book Company, 1991

Tarr A A, Liew K L and Holligan W, *Australian Insurance Law*, 2nd edn, Law Book Company, 1991

Wicken's Law of Life Insurance in Australia, 6th edn, loose-leaf, Law Book Company, 1991

76023

Deceptive Trade Practices and Product Liability

6cp; prerequisite: 70417 *Corporate Law*; corequisite: 70318 *Personal Property*

The following topics are considered: the constitutional basis of the *Trade Practices Act*; liability under the *Trade Practices Act* and Fair Trading legislation for misleading and deceptive conduct; remedies and criminal liability under the *Trade Practices Act*; liability for unconscionable conduct; suppliers', service providers', financiers' and manufacturers' liability for defective products (including standards and bans).

Texts and references

Beerworth E E, *Product Liability*, Federation Press, 1989

Miller R V, *Annotated Trade Practices Act*, 13th edn, Butterworths, 1992

Pengilly W, *Misleading and Deceptive Conduct*, Legal Books, 1991

76024

Environmental Law

6cp; prerequisite: 70617 *Administrative Law*

The following topics will be considered: the philosophy of environmental law; the constitutional support for environmental actions; the legislative framework of both the Commonwealth and the States; the concept of ecologically sustainable development; the precautionary principle and its implementation through the legal process; pollution law in NSW, covering the system of licensing and regulations; land use control; the use of natural resources (such as mining and forestry); the role of the courts - Supreme Court, the Land and Environment Court and the Local Court.

Texts and references

Bates G, *Environmental Law in Australia*, 3rd edn, Butterworths, 1992

Farrier D, *Environmental Law Handbook*, Redfern Legal Centre Publishing, 1988

Local Government, Planning and Environment Service, loose-leaf, Butterworths

Preston B, *Environmental Litigation*, Law Book Company, 1989

76026**Local Government Law**

6cp; prerequisite: 70617 *Administrative Law*

This subject covers the functions, powers and duties of local government authorities, including the following topics: councils, members of council, council servants, council meetings, council powers, enforcement of local government and planning laws; control of local government authorities, administrative review, judicial review, common law actions against councils and their employees; finance, rates, valuation of land; acquisition of land; land use control, land use planning, development control; building regulation; subdivision; liquor law as it affects councils.

Texts and references

Local Government Planning and Environment (NSW), Vol. C, loose-leaf, Butterworths

Pearson L, *Local Government Law in New South Wales*, Federation Press, 1994

76027**Restrictive Trade Practices**

6cp; prerequisites: 70317 *Real Property*; 70318 *Personal Property*

Topics include introduction to economics; constitutional issues; monopolisation and relevant market analysis; mergers; anti-competitive agreements; resale price maintenance; price discrimination; exclusive dealing; and international anti-trust and extraterritoriality.

Texts and references

Corones S G, *Competition Law and Policy in Australia*, Law Book Company, 1990

Heydon J D, *Trade Practices Law*, loose-leaf, Law Book Company

Hurley A, *Restrictive Trade Practices: Commentary and Materials*, Law Book Company, 1991

Miller R V, *Annotated Trade Practices Act*, 13th edn, Law Book Company, 1992

Neale A D and Goyder D G, *The Antitrust Laws of the USA*, 3rd edn, Cambridge University Press, 1980

Ransom A and Pengilly W, *Restrictive Trade Practices: Judgments, Materials and Policy*, Legal Books, 1985

Tapperell G Q, Vermeesch R B and Harland D J, *Trade Practices and Consumer Protection*, 3rd edn, Butterworths, 1983

76028**Advanced Company Law**

6cp; prerequisite: 70417 *Corporate Law*

This subject deals with current developments in company law and may be expected to cover topics drawn from equity finance, debt finance, takeovers, securities markets, company management and companies in difficulty.

Text

Ford H A J and Austin R P, *Ford's Principles of Corporations Law*, 6th edn, Butterworths, 1992

76029**Land Dealings**

6cp; prerequisite: 70317 *Real Property*

Examines the law of conveyancing in detail, covering the following topics: the formation of an enforceable contract; agreements and deeds; open contracts; *caveat emptor*, pre-contract inquiries and vendor disclosure; auction sales; deposits; risk and duty of care pending completion; statement of title; requisitions and objections; right of rescission; defects in title; errors and misdescription; legality of use and structures; inquiries and affectations; rates and notices; vacant possession; time for completion; and remedies.

Texts and references

Butt P J, *Standard Contract for the Sale of Land in NSW*, with supplement, Law Book Company, 1989

Conveyancing Law and Practice in NSW, loose-leaf, CCH

Conveyancing Service, loose-leaf, Butterworths

Skapinker D, *Sale of Land: Commentary and Cases*, 3rd edn, Legal Books, 1994

Rossiter C J, *Vendor and Purchaser: Commentary and Materials*, Law Book Company, 1985

76037**Advanced Criminal Law**

6cp; prerequisites: 70217 *Criminal Law*; 70417 *Corporate Law*

The subject is aimed at developing research, writing and analytical skills in developing areas of criminal law. Topics covered include issues arising out of the proposed Model Criminal Code for Australia, including attempt, strict and vicarious liability, the liability of companies and their officers, complicity, conspiracy, and the burden of

proof. Developments in defences of provocation, duress and consent are analysed. Criminal liability issues such as intention, knowledge and recklessness are reviewed. Current topics such as proceeds of crime, investigative agencies' powers, Aboriginal persons, street offences, white-collar offences, complex fraud trials and the proposed uniform evidence Bills are discussed. The role of the criminal appellate law procedure is reviewed.

Text

Johnson P and Howie R, *Criminal Practice and Procedure in New South Wales*, Butterworths

76039

Jessup International Moot

6cp; prerequisite: 76900 Moot

This elective encourages participation in the Jessup International Moot. This moot was established in 1962 by the American Society of International Law and is named in honour of Professor P C Jessup, Professor of International Law and Diplomacy at Columbia, and judge of the International Court of Justice 1960–69. The moot is now organised by the Association of Student International Law Societies, which operates under the auspices of the American Society of International Law in Washington. The moot is probably the most prestigious of international moots. Australia first entered the competition in 1977 and the University first entered a team in 1983.

The workload involved is particularly demanding: the problems circulated are on complex and current issues of international law. Detailed research into both international and comparative law is essential to prepare complex pleadings for both sides with a maximum size prescribed. The work involved is certainly no less than that for a large research project. The memorials are assessed by memorial judges, often including distinguished teachers of international law who do not sit in the round. In addition, there are at least two separate assessments of the moot by benches. These will typically consist of law teachers, practitioners and judges.

Because of the rules of the Jessup Moot, no assessment will be available until after the conclusion of the Australian finals of the Jessup Moot each year.

76040

Research Project 4

6cp; prerequisites: completion of all core subjects

The aim of the Research Project is to further develop students' research skills. Students are required to demonstrate a high level of understanding of the law relevant to the topic; the capacity to research and analyse legal material; the ability to use research tools and skills; and the ability to present the results of the research in a coherent and comprehensive form.

Experience shows that most students require two semesters to complete a Research Project and are therefore advised to commence work and submit a proposal at least 12 months before anticipated completion of the Law course. If the project is to continue over two semesters students must also enrol in the subject in the second semester and pay HECS. Students must obtain the signed approval of the Subject Coordinator of their Research Project topic together with that of their proposed supervisor before they may enrol in the subject. The Research Project regulations are set out in this handbook under 'Regulations of the Faculty of Law'.

76042

Communications Law

6cp; prerequisites: 70417 Corporate Law; 70617 Administrative Law

This course explores the laws which affect participants in Australia's communications industries. Telecommunications, broadcasting and the print media have been the traditional focus of this course; but the blurring of the boundaries of these media, in particular the exponential growth of the Internet, now requires a much broader approach. The course is divided equally between the laws which affect the content (words, sounds and pictures) published/transmitted in these media, and the laws which affect the conduct of the corporations providing communication services.

The laws relating to Defamation, Contempt of Court, Privacy and Censorship, are considered in the context of the expression 'freedom of speech'. How free is speech in Australia?

The *Telecommunications Act 1997*, the *Trade Practices Amendment (Telecommunications) Act 1997*, and the *Australian Communications Authority Act 1997*, came into effect on July 1 1997. These Acts are the mechanism by which

full competition was introduced into the Australian telecommunications market.

The wide powers given to the ACCC to prevent anti-competitive conduct in a market which, until recently, Telstra dominated through a statutory monopoly, will be examined. The role of the newly created Australian Communications Authority, which takes over roles previously performed by the Australian Telecommunications Authority and the Spectrum Management Authority, will be considered.

The *Broadcasting Services Act 1992*, in particular the complex provisions known as 'Cross-media Rules', has been the subject of much criticism and review. The elements of the Act which have prevented Mr Kerry Packer acquiring control of Fairfax newspapers will be considered; as will the role of the Australian Broadcasting Authority, and industry 'self-regulation' schemes.

Texts and references

Armstrong M (ed.), *Telecommunications Law: Australian Perspectives*, Globe Press, 1990

Armstrong M, Blakeney M and Watterson R, *Media Law in Australia: A Manual*, Oxford University Press, 1988

Grey M, Orr R, Hitchens L and Armstrong M, *Communications Law and Policy in Australia*, loose-leaf, Butterworths

Walker S, *The Law of Journalism in Australia*, Law Book Company, 1989

76044

Advanced Family Law

6cp; prerequisite: 76516 Family Law

This subject will explore the legal relationships arising between members of families with particular emphasis on families involved in a breakdown of their family unit. Families constituted under the *Family Law Act 1975* and through de facto relationships will be the main focus of this subject. Other family units (e.g. gay and lesbian couples) will be referred to whenever relevant to the laws being studied.

Topics will include the financial consequences of family breakdowns; adoption and other family issues, child support, injunctive relief and apprehended violence orders; dispute resolution, practice and procedure; and reform issues.

Texts and references

Dicky A, *Family Law*, 3rd edn, Law Book Company, 1997

Finlay H, *Family Law Cases and Materials*, Butterworths

Parker S, *Australian Family Law in Context*, Law Book Company

76045

Law and Medicine

6cp; prerequisite: 70617 Administrative Law

Deals with those areas of law that interact with the practice and administration of medicine and other health services. It includes the following topics: professional liability and medical negligence (including the issue of patient consent); medical ethics and issues, such as abortion, euthanasia and *in vitro* fertilisation; medical records (access and confidentiality); expert medical evidence in criminal and civil cases; regulation of the medical profession and health services (licensing and certification, review of administrative decisions affecting doctors and health workers, health insurance, public health); and legal aspects of mental health and intellectual disability (including legal capacity, the administration of the estates of mentally ill and intellectually handicapped persons, and the rights of mentally ill and intellectually handicapped persons generally).

Text

Dix A, Errington M, Nicholson K and Power R, *Law and the Medical Profession*, Butterworths, 1988

76046

Women and the Law

6cp; prerequisites: 70211 Law of Contract; 70311 Law of Tort

This subject examines the role of the law in constructing and dismantling inequalities between men and women, and women's place in society and within the legal profession.

Students will be expected to become familiar with the substantial body of knowledge relating to feminist jurisprudence and to conduct their own research into particular areas of the law. Classes and assignments will involve the formulation of ideas and theories from relevant materials and also critical assessment of those ideas and theories. The subject deals with the role of the law in constructing and deconstructing inequalities between women and men; women and crime (women as criminals and victims of crime); women and sexuality; and women and work.

Texts and references

Graycar R and Morgan J, *The Hidden Gender of Law*, Federation Press

Edwards S, *Sex and Gender in the Legal Process*, Blackstone, 1996

Smart C, *Feminism and the Power of Law*, Routledge, 1995

Naffine N, *Feminism and Criminology*, Allen and Unwin, 1997

76047**Advanced Contracts**

6cp; prerequisites: 70211 Law of Contract; 70516 Equity and Trusts; 71116 Remedies

This subject addresses the question of how contract law assists in the negotiation and enforcement of agreements, as well as the resolution of disputes arising out of agreements. It will deal with selected areas of practical relevance and legal difficulty in the application of principles of contract law to various transactions (uncertainty, the exercise of judicial discretion to fill gaps in agreements, implied terms, illegality, termination of contracts); the intervention of equity (estoppel, penalties, relief from forfeiture, restitution, unconscionability); legislative intervention (*Trade Practices Act 1974* (Cth), *Fair Trading Act 1987* (NSW), *Contracts Review Act 1980* (NSW)); and the relationship between tort law and contract law, with reference to the law of obligations.

Texts and references

Burrows A, *The Law of Restitution*, Butterworths, 1993

Cheshire and Fifoot's Law of Contract, 7th Aust. edn, Butterworths, 1997

Greig D W and Davis J L R, *The Law of Contract*, with latest cumulative supplement, Law Book Company, 1987

Meagher R P, Gummow W M C and Lehane J R F, *Equity: Doctrines and Remedies*, 3rd edn, Butterworths, 1992

Tettenborn A M, *An Introduction to the Law of Obligations*, Butterworths, 1984

76048**Citizenship and Immigration Law**

6cp; prerequisite: 70617 Administrative Law

This course deals with the development of a distinct Australian citizenship, the right to travel and immigration control in Australia. Constitutional law issues, the legislative

framework and the Australian Government's humanitarian and international obligations are treated. Particular topics include granting of citizenship, passports, statutory concept of entry, refugee status, change of status, deportation, government policy, immigration programs, departmental procedures and a comparative study of immigration control systems.

Texts and references

Bevan V, *The Development of British Immigration Law*, Croom Helm, 1986

Burnett R, *Australian Immigration Law*, loose-leaf, Butterworths

Department of Immigration, Local Government and Ethnic Affairs, *Procedures Advice Manual*, loose-leaf, AGPS

Fransman L, *British Nationality Law*, Fourmat Publishing, 1989

Pryles M, *Australian Citizenship Law*, Law Book Company, 1981

76049**Transport Law – Selected Problems**

6cp; prerequisites: 70211 Law of Contract; 70311 Law of Tort; 70516 Equity and Trusts

This subject deals with the legal regime governing the operation of the domestic and international transportation systems. Topics include the regulatory regime of air, sea, land (road/rail), and multi-modal transport; the carriage of goods and passengers by sea (intrastate, interstate and international carriage; charter parties; bills of lading; admiralty jurisdiction; maritime liens; salvage; general average); domestic and international carriage; of goods, luggage, baggage and passengers by air (especially the Warsaw Convention); the carriage of goods by land and rail; and legal issues connected with the multi-modal transport of goods.

Texts and references

Chorley R S and Giles O C, *Shipping Law*, 8th edn, Pitman, 1987

Davies M and Dicky A, *Shipping Law*, Law Book Company, 1990

Diederiks-Verschuur D I, *An Introduction to Air Law*, 4th edn, Kluwer, 1991

Hill C, *Maritime Law*, 3rd edn, Lloyds, 1989

Mankiewicz R H, *The Liability Regime of the International Carrier*, Kluwer, 1981

Shawcross and Beaumont, *Air Law*, loose-leaf, Butterworths

White M W D, *Australian Maritime Law*, Federation Press, 1991

Tetley W, *Marine Cargo Claims*, 3rd edn, Blais, 1998

76051

International Trade Law

6cp; prerequisites: 70617 *Administrative Law*; 76112 *Conflict of Laws*

This subject deals with legal aspects of international business transactions. An introductory segment explaining the international legal framework for the conduct of international trade in goods and services is followed by sessions dealing with the law relating to international sale of goods (governed by the International Convention on Sale of Goods), the law relating to international carriage of goods (governed by international conventions and international custom), the alternative methods for conduct of international business including joint ventures and countertrade, government mechanisms controlling entry of goods and unfair trading practices such as dumping and subsidisation of goods, financing international transactions (which will be primarily concerned with Uniform Rules for Documentary Credits) and international governmental agreements regulating trade in services.

Text

Burnett R, *The Law of International Business Transactions*, Federation Press

76052

Dispute Resolution

6cp; Co-requisite: 71005 *Practice and Procedure*

The subject deals with the jurisprudence of dispute resolution, and the theory, dynamics and essential characteristics of each dispute resolution process, so that effective strategies for resolving a wide range of disputes can be formulated. Students will be given some exposure to, and training in, dispute resolution so that they can improve their use of negotiations, mediation and arbitration in practice. Topics include the concept of dispute resolution, including negotiations, mediation, conciliation and arbitration; the nature of disputes; existing dispute resolution procedures; and the theoretical, ethical and practical issues of negotiation and mediation.

Texts and references

Astor H and Chinkin C, *Alternative Dispute Resolution in Australia*, Butterworths

Fisher R and Ury W, *Getting to Yes*, Penguin

76053

Industrial Law

6cp; prerequisites: 70217 *Criminal Law*; 70311 *Law of Tort*

Examines the Australian system for resolving industrial disputes by compulsory conciliation and arbitration. It concentrates on the federal arbitration system (and on federally registered unions), but reference will be made to State and overseas legislation, where appropriate. Topics include constitutional limitations to federal power; the workings of the *Workplace Relations Act 1996*, including the content of awards; the legal status of trade unions; the legislative controls upon a trade union's internal affairs; protection of unionism; and legal controls over trade unions.

Texts and references

Australian Industrial Law Review, CCH

Australian Labour Law Reporter, loose-leaf, CCH

Creighton B et al, *Labour Law Text and Materials*, Law Book Company, 1993

Gunningham N, *Industrial Law and The Constitution*, Federation Press, 1988

McCallum, Pittard and Smith, *Australian Labour Law: Cases and Materials*, 3rd edn, Butterworths, 1995

76054

Advanced Public Law

6cp; prerequisites: 70616 *Federal Constitutional Law*; 70617 *Administrative Law*

This elective subject builds on the knowledge acquired by students in the subjects 70616 *Federal Constitutional Law* and 70617 *Administrative Law*. Topics covered in lectures will include freedom of speech; freedom of assembly and association; due process; parliamentary restriction of judicial review; public policy; nationhood; an Australian republic; and recent developments in constitutional and administrative law.

Texts and references

Aronson M and Franklin N, *Review of Administrative Action*, Law Book Company

Craig P P, *Administrative Law*, Sweet & Maxwell

Harlow C and Rawlings R, *Law and Administration*, Weidenfeld and Nicolson

Stein L (ed.), *Locus Standi*, Law Book Company

Thynne I and Goldring J, *Accountability and Control: Government Officials and the Exercise of Power*, Law Book Company

Whitmore H and Aronson M, *Public Torts and Contracts*, Law Book Company

Zines L, *The High Court and the Constitution*, Butterworths

Sampford C and Preston K, *Interpreting Constitutions*, Federation Press, 1996

76059

Advanced Conflict of Laws

6cp; prerequisite: 76112 Conflict of Laws

This course is designed to enhance understanding of the conflict of laws, and is particularly directed to students who wish to practise in the areas of international law, maritime law, property, the administration of estates and government work. The course will cover the following topics: the historical and theoretical development of the conflict of laws; service and execution of process in Australia and internationally; choice of law in property; choice of law in succession; choice of law in the administration of estates; and governmental seizures of property

Texts and references

Collins L, *Dicey and Morris on the Conflict of Laws*, Vols 1 & 2, 12th edn, Sweet & Maxwell, 1993

McClean, J D, *Morris: The Conflict of Laws*, 4th edn, Sweet & Maxwell, 1993

North P M and Fawcett J J, *Cheshire and North's Private International Law*, 12th edn, Butterworths, 1992

Nygh P E, *Conflict of Laws in Australia*, 6th edn, Butterworths, 1994

Sykes E I and Pryles M C, *Australian Private International Law*, 3rd edn, Law Book Company, 1991

Sykes E I and Pryles M C, *Conflict of Laws: Commentary and Materials*, Law Book Company

76060

Advanced Constitutional Law

6cp; prerequisite: 70616 Federal Constitutional Law

This course will concentrate on the following topics: principles of constitutional interpretation and the characterisation of federal laws; human rights and Australian constitutional interpretation; freedom of speech; freedom of

religion; freedom of assembly and association; trial by jury; eminent domain and the compulsory acquisition of property; developing concepts of 'nationhood' in Australian constitutional law; constitutional reform; a federal republic of Australia; federal jurisdiction and choice of law; extra-territoriality; the relationship between public international law and constitutional law; and federalism.

Texts and references

Booker K, Blass A and Watt R, *Federal Constitutional Law*, Butterworths, 1995

Hanks P, *Australian Constitutional Law: Materials and Commentary*, 5th edn, Butterworths, 1995

Lumb R D and Moens G, *Constitution of the Commonwealth of Australia Annotated*, 5th edn, Butterworths, 1995

76061

Advanced Administrative Law

6cp; prerequisite: 70617 Administrative Law

This course is designed to supplement material covered in 70617 Administrative Law, and will place emphasis on both the theoretical aspects of administrative law, and practices and procedural aspects of federal administrative law.

Text

Allars M, *Introduction to Australian Administrative Law*, Butterworths, 1990

76062

Social Security Law

6cp; prerequisite: 70617 Administrative Law

The aim of this course is to develop an understanding of income support legislation in Australia: benefits for the infirm, unemployed and disabled people; sole parent benefits; aged pensions; pharmaceutical benefits etc. The focus of the course is on federal law, and specifically the *Social Security Act 1991* (Cth) and its amendments.

Texts and references

Carney T and Hanks P, *Social Security in Australia*, Oxford University Press, 1994

Sutherland P, *The Annotated Social Security Act*, Federation Press, 1994

76063**Media Law**

6cp; prerequisites: 70311 *Law of Tort*; 70616
Federal Constitutional Law

This course examines a range of topics concerning law and the media, including defamation; contempt; freedom of speech; vilification; obscenity and pornography, the regulation of the Internet, privacy, 'whistleblowing', and representations of law in the media, particularly on television. Through close examination of the cases and literature, students will be required to consider critically the nature of liberalism, power and democracy as they relate to law and the mass media.

Texts and references

Walker S, *The Law of Journalism in Australia*, Law Book Company, 1989

Armstrong M, Lindsay D and Watterson R, *Media Law in Australia*, 3rd edn, Oxford University Press, 1995

Campbell T and Sadurski W (eds), *Freedom of Communication*, Dartmouth, 1994

76064**Law and Natural Resources**

6cp; prerequisite: 70616 *Federal Constitutional Law*

Woodchipping! Ecotourism! Driftnet fishing! Uranium mining! Australia is rich in natural resources, but their exploitation has generated a great deal of conflict. This subject aims to introduce students to issues of resource management and conservation, and to consider the various legal regimes that have developed as a result of them. Students will be required to think critically about the basis and function of legal regulation in an area which is renowned for its ability to create conflict between different sectors of society.

Texts and references

Mercer C, *A Question of Balance*, 2nd edn, Federation Press, 1995

Ramsay R and Rowe G, *Environmental Law and Policy in Australia: Text and Materials*, Butterworths, 1995

76065**Finance Law**

6cp; prerequisite: 70417 *Corporate Law*

This subject provides an overall understanding of the legal aspects of the Australian financial

system with emphasis on the legal character and operations of the financial institutions. Specific topics covered include financial institutions and customer relations, negotiable instruments, electronic banking, lending and consumer finance, international banking and environmental issues and financial institutions.

Text

Blay and Clark, *Australian Law of Financial Institutions*, 2nd edn, Harcourt Brace, 1996

76066**Children and the Law**

6cp; prerequisites: 70217 *Criminal Law*; 76516
Family Law

This course is designed to supplement studies covered in 76516 Family Law and 70217 Criminal Law and will place emphasis on issues such as children's rights, equality issues, juvenile justice, criminal and care issues, representation in civil proceedings, and medical procedures and treatment.

Texts and references

Blackmore R D, *The Children's Court and Community Welfare in NSW*, Longmans, 1989

Dickey A, *Family Law*, 2nd edn, Law Book Company, 1990

76067**Legal Method**

6cp; prerequisites: 70113 *Legal Process and History*; 70105 *Legal Research*

This subject supplements work done in 70113 Legal Process and History and in particular provides students with an opportunity to refine and further develop their skills of case analysis and statutory interpretation. Students will also be introduced to basic skills in legal drafting. These legal method skills are critical to both the study and practice of law. In addition to practical exercises, students will also be asked to explore wider, more theoretical, issues relating to legal reasoning and law-making.

Texts and references

Morris G et al, *Laying Down the Law*, Butterworths

Cross R, *Precedent in English Law*, Clarendon Press

Pearce D C and Geddes R S, *Statutory Interpretation in Australia*, Butterworths

76068**Indigenous Peoples and the Law**

6cp; prerequisite: 70217 Criminal Law

The relationship between Indigenous peoples and the law goes to the foundation of Australia's legal and political identity. Competition for land ownership has defined and driven race relations in Australia. This course will examine the historical dispossession of Indigenous people with reference to how this has impacted on current legal relations and debates. The dispossession by law and war together with the belated and partial recognition of Indigenous peoples in the Mabo(2) decision will be evaluated. Land rights legislation, native title legislation and subsequent developments including the Wik decision will be examined.

Indigenous Australians are the most incarcerated people in the world. Indigenous peoples' relations with the criminal justice system with particular reference to community/police relations will be considered. Dispersal of communities and forced removal of children from their families have possibly had the most devastating impact of all colonial policies on Indigenous peoples. These will be considered in detail with particular reference to current impacts on these people in areas such as welfare law, juvenile justice and family law.

Between 1972 and 1995, all Federal governments had a policy of self-determination with regard to Indigenous peoples. The meanings and implications of this policy will be examined in the context of self-determination policies in comparable countries such as Canada and the United States. Consideration will be given to the formation and role of Indigenous corporations, Australian and Canadian models of self-government, the Aboriginal and Torres Strait Islander Commission and international standards and developing norms.

Texts and references

No prescribed text, however, the following books and reports will be useful.

McRac H, Nettheim G and Beacroft L, *Aboriginal Legal Issues*, Law Book Company Sydney, 1991

Cunneen C and Libesman T, *Indigenous People and the Law in Australia*, Butterworths, 1995

Johnston E, Royal Commission into Aboriginal Deaths in Custody, *National Report*, Volume 2, Australian Government Publishing Service, 1991

Wootten H, Royal Commission into Aboriginal Deaths in Custody, *Regional Report of Inquiry in New South Wales, Victoria and Tasmania*, Australian Government Printing Service, 1991

Human Rights and Equal Opportunity Commission, *Final Reports of the Inquiry into the Separation of Aboriginal and Torres Strait Islander Children from their Families*, forthcoming 1997

Reynolds H, *The Law of the Land*, Penguin, Ringwood, 1987

Rowley C, *Destruction of Aboriginal Society*, Penguin, Harmondsworth, 1972

76069**Community Legal Research**

6cp; prerequisite: 70417 Corporate Law; 70617 Administrative Law

Community Legal Research is an elective subject where students will benefit in the following ways:

- students will gain an understanding of the impact of laws both specifically and generally on particular communities, on the community in general and on particular identifiable groups in the community
- students will be exposed to the dynamics of law reform, community consultations and the impact of politics on the legal system
- the research function of the UTS Community Law and Research Centre will provide students with important analytical and research skills invaluable to the legal profession
- the research and legal service functions of the Centre will provide students with a vital appreciation of the link between the profession, the community, individuals, ethics, power dynamics, social justice and the values of the legal system.

Research briefs prepared by Community organisations, the Centre or other Community Legal Services in collaboration with the Centre will be undertaken by students in research project groups of three-five students per group.

The research project will be in furtherance of the aims of the UTS Community Law and

Research Centre which are to help educate communities as to their legal rights, encourage self-help and promote community law reform. This course is unique to UTS. It is designed to illustrate the connections between and impact of the operation of law and various communities. The course emphasises and examines the potent impact that certain laws have on specific communities and the important role that legal practitioners can play in engaging in socio-legal debate and law reform.

76070

Biomedical Law and Bioethics

6cp; prerequisite: 70311 *Law of Tort*

The subject aims to give an appreciation of the effectiveness of law in regulating new medical developments. The subject seeks to examine the impact which emerging technologies may have on society and to explore the possible legal solutions to deal with the challenges presented by such technologies. A diverse range of issues are considered, these include:

Human Genes: the Human Genome Project; testing for insurance purposes; genetic engineering; genetic fingerprinting, eugenics; privacy and confidentiality; human cloning; international regulation.

Medical Experimentation and Research: regulation and history of medical research; the limits of research; therapeutic and non-therapeutic research, foetal tissue transplantation; drugs.

Reproductive Technology: includes discussion of legal regulation of procedures such as in-vitro fertilisation; artificial insemination; confidentiality; keeping of records; licencing; anonymity; embryo storage; access; nature of motherhood, parenthood, fatherhood; inheritance; sex selection.

Surrogacy: history; international perspectives; definition; scope of present law; legal distinctions between altruistic and commercial surrogacy; legal regulation of genetic, gestational and social parenthood; liability, protection and regulation of behaviour of parties to a surrogacy arrangement and third parties; advertising; interest of child.

HIV/AIDS: history, legal responses; the battle with disease.

Biotechnology: regulation of experimentation with animal and plant genetic material; international response.

Texts and references

There is no textbook covering the whole field. Readings for this subject are comprised of various texts, journals, reports and conference papers. Helpful texts include:

Bennett B, *Law and Medicine*, Law Book Company, 1997

McFarlane P, *Health Law Commentary and Materials*, 2nd edn, Federation Press, 1995

76112

Conflict of Laws

6cp; prerequisites: 70617 *Administrative Law*; 70616 *Federal Constitutional Law*

The subject deals with the international jurisdiction of the Australian courts, the recognition and enforcement of foreign judgments and decrees, and the problem of choice of law as it arises with respect to areas such as marriage, matrimonial causes, contract, torts, *inter vivos* property transactions and succession. The subject also deals with choice-of-law issues as they arise between the Australian States.

Texts and references

Collins L, *Dicey and Morris on the Conflict of Laws*, 11th edn, with 1991 supplement, Sweet & Maxwell

Morris J H C, *The Conflict of Laws*, 3rd edn, Sweet & Maxwell, 1984

Nygh P E, *Conflict of Laws in Australia*, 6th edn, Butterworths, 1994

Sykes E I and Pryles M C, *Australian Private International Law*, 3rd edn, Law Book Company, 1991

Sykes E I and Pryles M C, *Conflict of Laws: Commentary and Materials*, 3rd edn, Law Book Company, 1988

76115

Insolvency

6cp; prerequisite: 70417 *Corporate Law*

This subject is in two sections. The first half deals with bankruptcy, including: debtors' petitions; creditors' petitions; acts of bankruptcy; bankruptcy notices; property available to creditors; effect of bankruptcy on property and legal proceedings; proofs of debt; meetings of creditors after bankruptcy; realisation of the bankrupt's estate; discharge annulment and arrangements with creditors outside bankruptcy. The second half covers the

winding up of insolvent companies, including: the statutory demand procedure, commencement of winding up; effect of winding up on the company, directors and creditors; appointment and powers of the liquidator; property available to creditors; proof of debt; challenging the liquidator's decisions; and termination of winding up.

Texts and references

Australian Corporations Law, loose-leaf, Vol. 1, Chap 5.4, Butterworths

College of Law *Corporate Insolvency*, Seminar Papers 91/38, 1991

Lewis, *Australian Bankruptcy Law*, 9th edn, by Rose D, Law Book Company, 1990

McDonald, Henry and Meek, *Australian Bankruptcy Law and Practice*, 5th edn, by Darvall C and Fernon N T F, loose-leaf, Law Book Company

McPherson B H, *The Law of Company Liquidation*, 3rd edn, Law Book Company, 1987

76212

Revenue Law

6cp; prerequisites: 70617 *Administrative Law*; 70417 *Corporate Law*; 70516 *Equity and Trusts*

The subject examines the legal principles that relate to revenue law in Australia. Topics covered include the structure and sources of tax law in Australia; tax policy and tax reform; income – concepts of income, income from labour, property and business, statutory extensions to the income base; deductions – general and specific deductions, substantiation; capital gains tax; fringe benefits tax; tax accounting; tax administration; tax avoidance and ethics.

Texts and references

Income Tax Assessment Act, 1936

Income Tax Assessment Act, 1997

Cooper G et al, *Income Taxation: Commentary and Materials*, 2nd edn, Law Book Company, 1993

Kobetsky and Dirkis, *Income Tax Essential Cases and Materials*, Federation Press, 1997

Lehmann J and Coleman C, *Taxation Law in Australia*, 4th edn, Law Book Company, 1996

Woellner R H et al, *Australian Taxation Law*, 5th edn, CCH, 1995

76411

Sale of Goods

6cp; prerequisite: 70211 *Law of Contract*

Topics include dispositions of personalty under the *Sale of Goods Act*; implied terms in contracts for the sale of goods, the 'nemo dat' rule; performance of contracts for the sale of goods; remedies of unpaid seller; brief treatment of relevant portions of *Trade Practices Act* (Cth).

Text

Helmore B A, *Commercial Law and Personal Property in NSW*, 10th edn, by Carter J W et al, Law Book Company, 1992

76516

Family Law

6cp; prerequisites: 70317 *Real Property*; 70616 *Federal Constitutional Law*

This subject introduces students to the principles which govern the legal relationship between members of families when there is a breakdown in the family unit, whether the legal relationship arises out of marriage or a de facto relationship. This subject will examine the law of divorce and nullity, property proceedings, parental responsibility for children and injunctive relief. The interaction between social issues, public policy and the relevant law is an important feature of the subject.

Text

Dickey A, *Family Law*, 2nd edn, Law Book Company, 1990

76517

Succession

6cp; prerequisites: 70318 *Personal Property*; 70317 *Real Property*

This subject deals with the formal and essential requirements for a valid will, based on an examination of the relevant legislation and the case law. Precedents for the drafting of wills will be analysed. Curial procedure for recognising the validity of wills and sanctioning the distribution of a deceased's property, as well as the impact of the *Family Provisions Act 1982*, will be studied. The consequences of intestacy will be considered. The rights and responsibilities arising out of the administration and distribution of deceased estates will be examined in depth.

Texts and references

Certoma G L, *The Law of Succession in New South Wales*, Law Book Company, 1987

Hardingham I J, Neave M A and Ford H A J, *Wills and Intestacy in Australia and New Zealand*, 2nd edn, Law Book Company, 1989

Hutley F C, Woodman R A and Wood O, *Succession: Commentary and Materials*, 4th edn by Wood O and Certoma L, Law Book Company, 1990

Mason and Handler, *Wills, Probate and Administration Service (NSW)*, loose-leaf, Butterworths

Rowland C and Tramsitt G, *Hutley's Australian Wills Precedents*, 4th edn, Butterworths, 1989

76701**Family Law and Women's Perspectives – Aboriginal and Torres Strait Islander People**

6cp; prerequisite: 76516 Family Law

This subject aims to provide the student with a knowledge of the legal solution to family problems relating to Aboriginal and Torres Strait Islander people. Students will examine the need to address areas of law reform in relation to Aboriginal and Torres Strait Islander people and family law.

The syllabus includes the following: marriage; evidence of Aboriginal cultural factors; recognition of traditional Aboriginal marriage; common law marriage – examination of conflicting authorities; statutory recognition – effect of *Marriage Act 1961* (Cth); statutory recognition for specific purposes – e.g. *Administration and Probate Act 1979* (NT) s.6(4); custody, adoption and child welfare – *Family Law Act 1975* (Cth); general principles and relevant factors relating to the welfare of Aboriginal children; traditional adoption – Torres Strait Islander people; statutory recognition of Aboriginal placement principles – e.g. *Community Welfare Act 1983* (NT) s.43(1) and s.69; child welfare – effect of *Children (Care and Protection) Act 1987* (NSW); adoption – special provisions which apply to Aboriginal children in Queensland, South Australia and Victoria; consultation – Children's Review Panel, *Children (Care and Protection) Act 1987* (NSW) s.87(d); and understanding of proceedings – assistance of Aboriginal Legal Service.

Texts and references

Bolger A, *Aboriginal Women and Violence: A Report for the Criminology Research Council and the Northern Territory Commission of Police*, North Australian Research Unit, Darwin, 1990

Carrington K, 'Aboriginal Girls and Justice; What Justice?'; *White Justice Journal for Social Justice Studies*, Vol. 3, Sydney, 1990

Chisholm R and Housego J, *Australian Family Law*, loose-leaf, Butterworths

Dickey A, *Family Law*, 2nd edn, Law Book Company, 1990

Finlay H A and Bailey-Harris R J, *Family Law in Australia*, 4th edn, Butterworths, 1989

Women's Issue, *Aboriginal Law Bulletin*, Vol. 2 ALB No. 46, October 1990, Aboriginal Law Centre, Faculty of Law, UNSW, Sydney, 1990

76702**Criminal and Civil Law – Indigenous Perspectives**

6cp; prerequisite: 70217 Criminal Law

This subject examines the effect of criminal and civil law as it affects Aboriginal and Torres Strait Islander people.

The syllabus explores in general Aboriginal and Torres Strait Islander people liable to and protected by the criminal law; status – extradition between States; indigenous aspects relating to bail; fitness to plead; selection of juries; unrepresented defendants; plea of guilt and claim of right; provocation; evidence – confessions and admissions; dying declarations; and compellability of traditional spouses.

Texts and references

Fisse B (ed), *Howards's Criminal Law*, 5th edn, Law Book Company, Sydney, 1990

Gilles P, *Criminal Law*, 2nd edn, Law Book Company, Sydney, 1990

Reference on Aboriginal Customary Law Research Paper 6A, *Cases on Traditional Punishment and Sentencing*, 1982, unpublished ref, *Halsburys Laws of Australia*, Butterworths, Sydney, 1991, p. 4835

Royal Commission into Aboriginal Deaths in Custody, final report (11 vols), AGPS, Canberra, 1991

76703**Australian Indigenous Customary Law – Incorporating Indigenous Land Issues**

6cp; prerequisite: 70317 Real Property

This subject examines the relationship of Aboriginal and Torres Strait Islander customary rights and the development of indigenous land rights culminating in the enactment of the *Native Title Act 1993* (Cth).

The syllabus includes the following: the evidence of Aboriginal and Torres Strait Islander customs and traditional law; statutory recognition of aspects of customary law including traditional interests in land or items of cultural heritage, traditional hunting, fishing and gathering rights; issues as to the admissibility of evidence pertinent to the veracity of Aboriginal and Torres Strait Islander customs and traditional law; legal proceedings relating to Aboriginal land claims; assertion of common law title to land; action arising under particular statutory provisions relating to Aboriginal customs; determination of disputes governed by traditional Aboriginal law or custom; and the effect of the decision of the High Court in *Mabo v. Queensland (No. 2)* (1992) and the *Native Title Act 1993* (Cth) – the Commonwealth approach to the recognition and determination of native title to land in Australia.

Texts and references

Bartlett R, *The Mabo Decision*, Butterworths, 1993

Woodward A E, *Aboriginal Land Rights Commission Second Report*, AGPS, Canberra, 1973

76704**Current Law Reform Proposals – Indigenous Perspectives**

6cp; prerequisite: 70616 Federal Constitutional Law

This subject examines the development of law reform as it affects Aboriginal and Torres Strait Islander people.

The syllabus will include the repeal of s.127 of the *Australian Constitution* in 1967 and the amendment of s.51 granting the Commonwealth concurrent power with the States over Aboriginal affairs; the relevance of s.109 of the *Australian Constitution* with regard to the external affairs power; the effect of the *Racial Discrimination Act 1975* (Cth) in

overriding the *Queensland Coasts Island Declaratory Act 1985* (Qld); human rights; anti-discrimination and racial vilification legislation; and the effect of the Reports of Inquiry into Aboriginal Deaths in Custody and Racist Violence in Australia.

Texts and references

Aboriginal and Torres Strait Islander Social Justice Commissioner, *First Annual Report*, AGPS, Canberra, 1993

Bird G, Martin G and Nielsen J (eds), *Indigenous Peoples and Law*, Federation Press, Sydney, 1996

Council for Aboriginal Reconciliation, *Council for Aboriginal Reconciliation*, AGPS, Canberra, 1993

Johnston E, *Royal Commission into Aboriginal Deaths in Custody, National Report*, 11 Vol. 2, AGPS, Canberra, 1991

76705**International Law and Treaty Obligations, State and Regional Protocols – Indigenous Peoples**

6cp; 70617 Administrative Law

This subject examines the development of basic human rights for Australian Aboriginal and Torres Strait Islander people within the framework of public international law.

The syllabus explores international law, incorporating treaties, conventions and customary international law; development of human rights law and the notion of human rights as being universal and inalienable; the recognition of the individual as a subject of human rights; main sources of international law – international conventions or treaties, international custom, the general principles of international law recognised by nation states, judicial decisions, and the teaching of the most highly qualified publicists.

Texts and references

Charlesworth H, 'The First Optional Protocol', *Law Institute Journal*, p. 1018

Hocking, *International Law and Human Rights Program*, Law Book Company, Sydney, 1988

Pritchard S, 'International Law', *The Laws of Australia – Aboriginal and Torres Strait Islanders*, Law Book Company, Sydney, 1993

McGoldrick D, *The Human Rights Committee: Its Role in the Development of the International Covenant on Civil and Political Rights*, Oxford University Press, 1990

Senate Standing Committee on Constitutional and Legal Affairs, *Two Hundred Years*, AGPS, Canberra, 1983

Steinberger, 'Sovereignty', *Encyclopedia for Public International Law*, Vol. 10, Holland, 1987

76706

Indigenous Dispute Resolution

6cp; prerequisite: 71005 Practice and Procedure

This subject examines the development of dispute resolution in traditional and contemporary Aboriginal and Torres Strait Islander society.

The syllabus covers alternative dispute resolution as a mechanism for issues concerning Aboriginal communities; implementation of alternative methods of dispute resolution embodying the cultural values of indigenous people; a recognition by non-indigenous people and organisations of indigenous alternative dispute resolution procedures; recognition of diversity between Aboriginal and Torres Strait Islander groups in resolving disputes by alternative dispute resolution procedures; examination of cultural differences between indigenous and non-indigenous Australians; and the comparative and distinctive values of Aboriginal dispute resolution compared to the values of the common law system.

Texts and references

Attorney-General's Legal Practice, *Native Title Act 1993: Legislation with Commentary*, AGPS, Canberra, 1993

Bartlett R, *The Mabo Decision*, Butterworths, Sydney, 1993

Behrendt L, *Aboriginal Dispute Resolution*, Federation Press, 1995

Howitt and Douglas, *Aborigines and Mining Companies in Northern Australia*, Alternative Publishing Cooperative, Australia, 1988

Recognition of Aboriginal Customary Laws, Report No. 31, Australian Law Reform Commission, AGPS, Canberra, 1986

Stephen M A and Ratnapala S (eds), *Mabo: A Judicial Revolution*, University of Queensland Press, 1993

76900

Moot

6cp; prerequisite: 71005 Practice and Procedure

Students must participate in two moots on points of law arising from a set of agreed facts before a judge or barrister. Attendance is required at weekly seminars, each two hours long. At these seminars, part of the time will be devoted to discussion of the essentials of appellate advocacy, and part to the practice of the skills required for this task. Students must present the moot judge with written submissions, including a list of authorities, at least seven days before the scheduled date of the moot. Students must pass each of the two moots to pass the subject. Attendance at a session lasting all day on the Saturday at the end of Week two of the semester is compulsory.

Texts and references

Law Faculty, *Guide to Mooting*

Mauet T, *Fundamentals of Trial Technique*, Longman, 1993

Steusser L, *An Introduction to Advocacy*, Law Book Company, 1993

Watt R, *Concise Legal Research*, Federation Press, 1995

POSTGRADUATE SUBJECTS

The availability category shows the degree program(s) in which the subject is offered. With the approval of the Director of Postgraduate Programs it may be possible to undertake relevant subjects that are not indicated. Written application must be made to the Director before the commencement of each semester of enrolment. Not all subjects or programs are offered every semester.

The following degree abbreviations are used for the sake of convenience (note that these are not necessarily the official UTS course abbreviations):

Graduate Certificate in Dispute Resolution	GCDR
Graduate Certificate in Law for Secondary Teachers	GCLST
Graduate Diploma in Law for Secondary Teachers	GDLST
Graduate Diploma in Legal Studies	GDLS
Master of Comparative Law	MCL
Master of Dispute Resolution	MDR
Master of Law (by coursework)	LLM
Master of Legal Studies	MLS
Master of Taxation	TAX
Doctor of Juridical Science	SJD
Graduate Supply	SUPPLY

Key to abbreviations for the LLM (by coursework) and MLS/GDLS majors:

{dr}	Dispute Resolution
{c}	Commercial Law
{ip}	Intellectual and Industrial Property Law
{il}	Industrial Law
{int}	International Law

77700

Advanced Legal Research

2cp; 1 semester; availability LLM, GDLS, MLS

These seminars are on the methodology of research appropriate to graduate study involving the primary and principal secondary sources of law in NSW and the Commonwealth of Australia. In addition, the sources of law in a selected number of jurisdictions – England, United States, New Zealand, Canada and the European Union – are considered. The sources of international law constitute a special topic. Advanced Legal

Research is a corequisite for Category B LLM candidates. It is a compulsory subject for MLS and GDLS.

77701

International Economic Law

6cp; 1 semester; {c}{int}; availability LLM, SJD

Designed to develop an understanding of the law governing the international economy and relations between participants in that economy. The concept of international economic law will be examined, and topics will include specific resource issues such as the common heritage; the deep sea bed; Antarctica; international legal regulation of investment, finance and trade; the institutions – IMF, IBRD, WTO; and the relationship between national and international economic law involving such concepts as extraterritoriality and sovereign immunity.

77702

Current Problems of Public International Law

6cp; 1 semester; {int}; availability LLM, SJD

Assists students to develop an advanced understanding of the subject, including topics such as recent developments; sources of public international law; dispute resolution; diplomatic immunity; the law of the sea; extradition and asylum; international protection and human rights; treaty practice and procedure; and the recognition of states and governments.

77703

International Business Transactions

6cp; 1 semester; {c}{int}; availability LLM, SJD

After an introductory segment dealing with the international trading system including expanded range of matters covered by GATT 1994, the subject is structured to give students an understanding of the law of international contracts for sale of goods at arms length as well as contracts concerning trade through closer business relationships with foreign entities such as joint ventures. Other contractual relationships intertwined with the principal contract for international sale of goods and/or services such as contracts for international carriage of goods and payment mechanisms are covered. Government mechanisms for regulating international trade between 'private' traders such as the customs regime are discussed. A segment of the course is also devoted to international services trade.

77704**European Union Law**

12cp; 1 semester; {c}{int}; availability LLM, SJD

The topics which will be discussed in this subject include the activities of the European institutions; the political and economic origins of the EU and its institutional structures (with emphasis on the European Court of Justice); the interrelationship between Community Law and the law of the 15 member States; and the free movement of goods, workers, capital and services. The subject will concentrate on the emerging transnational protection of social and economic rights and the jurisprudence of the European Court of Justice.

77705**Maritime Law**

12cp; 2 semesters; {c}{int}; availability LLM, SJD

This subject is divided into two main areas – admiralty law and the law on the carriage of goods by sea. In both cases, reference will be made to pertinent international conventions and their adoption (or otherwise) in Australia, as well as to current international deliberations. Within the first main group of topics, the areas of admiralty law studied include safety; registration, nationality and ownership of ships; sale and purchase of ships; securities (mortgages and maritime liens); admiralty jurisdiction; collisions and limitation of liability; salvage, towage and pilotage; and maritime employment. The second main group of topics examines the regulation of shipping conferences, and the rights and obligations of parties to contract for the carriage of goods by sea (carrier and shipper), with special reference to charterparties and bills of lading. The areas studied include anti-trust laws; the Hague; Hague–Visby and Hamburg Rules; seaworthiness and the duty to take care of cargo; and demurrage, general average, freight and marine insurance. Problems associated with inter-modal transport operations will also be discussed.

77706**Advanced Administrative Law**

12cp; 2 semesters; availability LLM, SJD

Topics will include major developments in the common law and in federal administrative law. Particular attention will be paid to developing forms of remedies, the alternative forms of review of administrative action through, for example, the Ombudsman, and current issues

and prospective developments. Administrative law is relevant to all forms of government activity, including regulation of trade and commerce.

77707**Advanced Constitutional Law**

12cp; 2 semesters; availability LLM, SJD

Constitutional law is at the heart of the Australian Legal system. This course will cover major developments in Constitutional law, focusing on current issues. This course will also encourage students to consider the broader context of Constitutional Law (e.g. social, economic, cultural and political) and will introduce students to various theoretical perspectives, such as feminism and comparative viewpoints.

77709**Planning and Development Law I**

6cp; 1 semester; {c}; availability LLM, SJD

Topics in this subject include government involvement in the planning and development process as developer and as intervener; executory discretions in the development process; individual participation in the planning process; review of decisions; a case study for the interaction between private rights and public interests; a case study for the interaction of planning law and environmental concerns and recent developments.

77710**International and Comparative Law Project**

12cp; 2 semesters; {int}; availability LLM, SJD, MCL

Owing to career commitments, most practising lawyers are unable to undertake postgraduate work overseas, and therefore miss the advantages of studying in a different culture and environment. In an endeavour to redress this, the Faculty of Law offers the International and Comparative Law Project. This subject permits a candidate to undertake an approved course of study overseas of a limited duration, and credit this towards the LLM (by coursework) or SJD program. Upon return to Australia, the candidate must present evidence of work completed which will be assessed; and further written work may be required. The Faculty has approved programs of study in various locations overseas e.g. the Hague Academy of International Law and Santa Clara University Law School. Other programs are available, or students may submit proposals

for alternative programs. Further details may be obtained from the Administrative Officer of Postgraduate Programs.

77711**Corporations, Finance and Securities**

12cp; 2 semesters; {c}; availability LLM, SJD

This subject considers a number of topics of current relevance to corporations law, securities law, and corporate finance. The topics covered in the course include takeovers; share buy-backs; the federal company law regime; investigations and related topics; developments in directors' duties; an overview of the financial markets; securitisation; the securities industry; controls on public offerings; criminal and civil sanctions relevant to the securities industry; financial advisers; secured and unsecured finance; corporate and unincorporated joint ventures; leasing; subordination; use of commercial paper as a financing technique; syndication and participation; credit facilities; taxation issues in the context of finance law.

77712**Deceptive Trade Practices and Product Liability**

12cp; 2 semesters; {c}; availability LLM, SJD

An advanced study of Parts V and VI of the *Trade Practices Act* (Cth) (and analogous legislation). Topics covered include deceptive trade practices; remedies; unconscionable conduct; and the liability of suppliers, service providers and manufacturers. Emphasis is placed upon recent legal developments.

77713**Tax Procedures, Sales Tax and Stamp Duties**

12cp; 2 semesters; {c}; availability LLM, SJD, TAX

The topics covered include the Commissioner's powers to obtain information; imputation of tax; administrative law and tax; tax avoidance; tax appeals and objections; sales tax; and stamp duties.

77714**Computerised Legal Information Systems**

6cp; 1 semester; availability LLM, SJD

The study of hypertext, free-text retrieval systems and knowledge-based applications (expert systems). Although principally a

practical subject, the implementation of programs which are capable of legal reasoning will necessitate consideration of the nature and types of such reasoning.

77715**Banking Law**

12cp; 2 semesters; {c}; availability LLM, SJD

This is an advanced study of banking law concentrating on relations between the bank and its corporate customers. The following topics are examined: the regulatory framework within which banks operate; the relationship between the bank and the customer; and the activities of banks, including cheques, bills of exchange, foreign currency lending, and secured and unsecured lending.

77716**International Trade Law**

12cp; 1 semester; {c}{int}; availability LLM, SJD

Topics include the sale of goods; representation overseas; finance; export credits and insurance; carriage of goods; arbitration and litigation; customs law; and international trade regulation.

77717**International Commercial Dispute Resolution**

12cp; 1 semester; {dr}{c}{int}; availability MDR, LLM, SJD, MLS, GDLS, GCDR, SUPPLY

Topics covered include negotiation in international commercial disputes; cross-cultural commercial negotiations; transnational aspects of arbitration; arbitration as contract; statutory regulation of arbitration; international arbitration law; the role of dispute resolution centres; arbitration institutions; and drafting and analysing arbitration agreements. A compulsory component of the subject is a three-day skills workshop.

Note: This subject cannot be taken if 77751 International Commercial Arbitration has already been completed towards the program.

77718**Air Law**

6cp; 1 semester; {c}{int}; availability LLM, SJD

This subject is dealt with at both the international and domestic levels. Topics include the regulation and organisation of aviation (including sovereignty); the system of

carrier liability with emphasis on the Warsaw system; third-party liability (including damage caused to third parties on surface, environmental damage and aviation products liability); aviation insurance; and security issues.

77719

Capital Gains Tax

12cp; 2 semesters; {c}; availability LLM, SJD, TAX

This subject involves an in-depth study of capital gains tax (CGT) including consideration of legislative amendments since the introduction of CGT. Most of the first semester will be spent covering the CGT fundamentals such as the meaning of assets, acquisition and disposal, cost base and consideration. The second semester will consider the application of CGT in special circumstances, such as for companies, trusts and partnerships as well as the international implications.

77720

International Taxation

12cp; 2 semesters; {c}{int}; availability LLM, SJD

This subject considers the following topics: changes enacted and proposed since the 1985 Tax Reform measures; impact of international tax changes on Australian businesses; capitalisation and foreign controllers; the foreign credit tax system and imputation system; Australian measures against tax havens; taxation of foreign service income; relocation of corporate residence offshore; tax consequences of international information flows; non-resident trusts; transfer-pricing; enforcement and compliance moves by the Australian Taxation Office; New Zealand and US experiences; and controlled foreign corporations.

77721

Restrictive Trade Practices

12cp; 2 semesters; {c}; availability LLM, SJD

This is an advanced study of the law and recent developments in the area. Where relevant, a comparative analysis will be undertaken and the regulation of competition in the US and the European Union will be studied. The subject examines the constitutional basis for the *Trade Practices Act 1974* (Cth), the recent developments to expand the applicability of the Act, and the rationale for such regulation from both a lawyer's and an economist's

perspective. The specific prohibitions which will be examined include misuse of market power, mergers, collusive conduct, exclusionary conduct, boycotts, exclusive dealing agreements and resale price maintenance. Current topics include the deregulation of government business enterprises.

77722

Advanced Media Law

12cp; 2 semesters; {c}; availability LLM, SJD

An examination of legal problems relating to both electronic and print communications. In the field of electronic communications, the various aspects of establishment and regulation will be considered. In addition, there will be a consideration of the law applicable to all media – defamation and contempt – particularly in relation to recent developments.

77724

International Banking and Financial Law

6cp; 1 semester; {c}{int}; availability LLM, SJD

An advanced study of monetary systems; monetary obligations; foreign money obligations; the problem of the governing law; sovereign risk; exchange control; covenants; default; and types of finance.

77725

Research Project

12cp; 2 semesters; availability LLM, SJD

Candidates for the LLM with Honours must undertake the Research Project; however, the Research Project may be approved for candidates for the LLM or SJD. Candidates undertaking the Research Project must research and write a paper of approximately 12,000–15,000 words of a standard suitable for publication on a topic approved by the Faculty. In most cases the Research Project will extend and develop research done in one or more of the LLM or SJD subjects already undertaken, but in appropriate circumstances a candidate may undertake a new topic. The Research Project is subject to rules approved by the Faculty Board; copies of the rules are available from the Administrative Secretary (Postgraduate).

77726**Patent Law of Australia***12cp; 2 semesters; {ip}; availability LLM, SJD*

Provides candidates with an opportunity to study the current law and practice relating to the protection of intellectual property rights in inventions and technological advances. Topics include confidential information; history of patents for inventions; current legislation and reform; subject matter; right to apply; employees' inventions and joint ownership; form of application; specifications and fair basing; novelty and obviousness; opposition; grounds of invalidity; Crown use; patents of addition; extensions of term; Patent Conventions; infringement; licences; assignment; remedies and penalties; and the value of the patent system in the economy.

77727**Design Law***12cp; 2 semesters; {ip}; availability LLM, SJD*

A study of the law relating to the registration of designs and an overview of the law of copyright. Topics include the history of registered design legislation; meaning of design; requirements for registration; novelty or originality; registration process; infringement; term; ownership of registered design; rights created by registration; rectification of the register; licences and assignment; compulsory licences; transition provisions; design and copyright overlap; relevance of the *Trade Practices Act 1974*; international obligations; and the *Circuits Layout Act 1988*. The overview of copyright law will encompass a consideration of both works and other subject matter under the *Copyright Act 1968*.

77728**Trademarks Law of Australia***12cp; 2 semesters; {ip}; availability LLM, SJD*

The subject comprises a study of the trademark monopoly, trademark protection and practice. Topics include passing off; trade libel; unfair competition; misleading or deceptive trademark conduct under the *Trade Practices Act 1974*; the *Trademarks Act 1995*; right to apply; purposes of registration; distinctiveness; deception and confusion; the possibility of protection for misappropriation rather than confusion; division of the register; defensive registration; certification marks; infringement; assignment; the registered user

system; the exploitation of marks; remedies; international conventions and commercial counterfeiting; and trademark jurisprudence.

77729**Chinese Trade and Investment Law***6cp; 1 semester; {c}{int}; availability LLM, SJD*

An introduction to the trade and investment law of the People's Republic of China. Topics include the role of law in China; the law-making process and interpretation; legal aspects of China's foreign trade; legal aspects of foreign investment in China; contractual and equity joint ventures and wholly owned foreign enterprises; taxation of foreign interests; foreign exchange control; securities and futures; special economic zones; banking and finance; and dispute resolution.

77730**Corporate Insolvency and Restructuring***6cp; 1 semester; {c}; availability LLM, SJD*

An advanced study of corporate insolvency law. Topics include the regulating structure; secured and unsecured creditors; reservations; liquidation; schemes of arrangement; official management; the role of directors and foreign companies; and foreign proceedings.

77731**Advanced Remedial Law: Damages***6cp; 1 semester; {c}; availability LLM, SJD*

An advanced study of the following topics: compensation and the measure of damages; the Once for All Rule; certainty; causation; remoteness; mitigation; contributory negligence; effect of taxation, inflation; interest; contrast of promissory, reliance, restitutionary and indemnity damages; concurrent liability in contract and tort; pre-contract expenditure; non-pecuniary loss; discretionary benefits; property damages; economic loss; damages in equity; date of assessment of damages; and punitive damages.

77732**Advanced Remedial Law: Equitable Remedies***6cp; 1 semester; {c}; availability LLM, SJD*

Topics include the inadequacy of damages; discretion – unconscionability and hardship; discretion – constant supervision, partial enforcement through injunction; discretion – lack of mutuality, unclean hands, laches, ready

willing and able, public interest; part performance; protection of private property rights; protection of public interest; urgent relief; Mareva injunctions and Anton Pillar orders; rescission; declaration; account; rectification and delivery-up of documents; and receivers.

77733

Chinese Law and Legal Systems

6cp; 1 semester; {int}; availability LLM, SJD

This subject provides a background to further specialist study of contemporary Chinese Law, including Chinese commercial law relating to foreign investment, Chinese communist legal styles, attitudes and structures, and traditional imperial Chinese legal attitudes and methods.

77734

Law and Medicine

12cp; 2 semesters; availability LLM, SJD

Deals with the areas of law that interact with the practice and administration of medicine and other health services. It includes medical negligence; consent; medical records; expert medical evidence in criminal and civil cases; the law of medical ethics; and legal aspects of mental health and intellectual disability, including legal capacity and the rights of mentally ill and intellectually handicapped persons generally.

77735

Dispute Resolution

12cp; 2 semesters; {if}{dr}; availability MDR, LLM, SJD, MLS, GDLS, SUPPLY

An introduction to the theoretical and practical aspects of this newly developing area which is applicable to all professions, business and government. It is designed to give an overview of the processes of dispute resolution which includes dispute prevention and minimisation, dispute management, and dispute system design. Topics include an overview of dispute resolution processes in Australia; the theoretical basis of the recent movement; an introduction to mediation and negotiation theory; communication skills; critiques of Alternative Dispute Resolution (ADR) and its implementation; and an introduction to dispute resolution programs in Australia. A compulsory component of the subject is a six-day mediator training workshop.

77736

Admiralty Law

6cp; 1 semester; {int}; availability LLM, SJD

This subject gives students an appreciation of public and private international law aspects of maritime commerce and transportation, while ensuring a knowledge of the Australian law governing the relevant areas selected for study. Reference is made to pertinent international conventions and their adoption (or otherwise) in Australia, as well as to current international deliberations. Topics include maritime safety; registration; nationality and ownership of ships; securities (mortgages and maritime liens); admiralty jurisdiction; collision and limitation of liability; salvage, towage and pilotage; and maritime employment.

77737

Carriage of Goods by Sea

6cp; 1 semester; {int}; availability LLM, SJD

This subject examines the regulation of shipping conferences, and the rights and obligations of parties to contract for the carriage of goods by sea (carrier and shipper), with special reference to charter parties and bills of lading.

77738

Advanced International Economic Law

6cp; 1 semester; {c}{int}; availability LLM, SJD

Designed to develop an advanced understanding of the law governing the international economy, and the relations between participants in that economy. Aspects of international economic law are considered, including the IMF; floating currencies; foreign exchange control law; international contracts – Article VIII of the IMF; aspects of international fiscal law; the European Monetary System; sovereign debt problems; and Eurocurrency markets.

77739

Indonesian Trade and Investment Law

6cp; 1 semester; {c}{int}; availability LLM, SJD

An overview of the legal system of Indonesia, with particular emphasis on trade and investment law. Topics will include the Indonesian legal system; business organisation; joint ventures; securities law; foreign investment; land law; exchange control; and litigation and arbitration.

77740

Research Paper

6cp; 1 semester; availability LLM, SJD

The Research Paper may be approved for LLM and SJD candidates. Candidates must submit a proposed topic to the Faculty Board for approval. This subject does not fulfil the Faculty Board's requirements for the awarding of Honours within the LLM.

77741

European Union Anti-Trust Law

6cp; 1 semester; {c}{int}; availability LLM, SJD

Designed to provide an understanding of the provisions of Articles 85 and 86 of the Treaty of Rome, with a brief survey of their relationship to one of the member states of the European Union (normally the UK).

77742

Advanced Comparative Law – The Common Law

12cp; 1 semester; availability GCCL (international students only)

This is an intensive subject which provides the bridge between the civil law and the common law. It opens with tuition and practical exercises in the research skills and methodology of the common law. The topics covered by Advanced Comparative Law are: primary and secondary sources of the common law; the development of the common law; courts and lawyers; the spread and reception of the common law; law finding in the common law; contract law in the common law; public law and the common law; and business transactions in the common law. The subject also involves visits to the courts and Sydney law offices. The program is open to graduates and lawyers from civil law countries; it would not normally be undertaken by those who have common law qualifications, or who are admitted to practise in a common law jurisdiction.

77743

Economic Law in Eastern Europe

6cp; 1 semester; {c}{int}; availability LLM, SJD

Topics to be covered include the functions of law in Eastern Europe; the legal environment of business; privatisation and re-privatisation policy and its legal forms; aspects of company law; banking law; taxation systems; anti-trust legislation; insurance and reinsurance;

securities markets; foreign investment laws; the EU and association agreements; OECD and 'Partners in Transition'; aspects of contracts in corporate business; and dispute resolution processes.

77744

Franchising Law

6cp; 1 semester; {ip}{c}; availability LLM, SJD

Introduces students to the role of franchising in the economy, the strengths and weaknesses of franchising, and the applicable law. Topics include trade practices and franchising; intellectual property and franchising; dispute resolution between franchisor and franchisee; taxation and stamp duty considerations; and international franchising.

77745

Negotiation

6cp; 1 semester; {if}{dr}; availability MDR, LLM, SJD, MLS, GDLS, GCDR, SUPPLY; prerequisite: 77735 or 79771 Dispute Resolution or demonstrated experience in the field

This subject is taught in a three-day skills-based course which is designed to provide an understanding of the theory and skills of negotiation. It covers the diverse approaches to negotiation concentrating mostly on principled negotiation as taught by the Harvard Law Faculty's Negotiation Project. The course utilises materials from the Project. Students' skills in negotiation will be developed. The subject covers the use of negotiation as a process of dispute resolution and for contract formation.

77746

Advanced Mediation

6cp; 1 semester; {if}{dr}; availability MDR, LLM, SJD, MLS, GDLS, GCDR, SUPPLY; prerequisite: 77735 or 79771 Dispute Resolution or demonstrated experience in the field

This subject concentrates on the micro-skills of mediation at an advanced level. It is designed to give students an in-depth understanding of the detail of the skills and techniques used by experienced mediators. The skills will be further developed to an advanced level. Co-mediation and mediation in multi-party disputes are also included.

77748**Victim–Offender Dispute Resolution**

6cp; 1 semester; {dr}; availability MDR, LLM, SJD, GCDR, MLS, GDLS SUPPLY; prerequisite: 77735 or 79771 Dispute Resolution or demonstrated experience in the field

The theory and practical implications of using the newer dispute resolution processes, particularly mediation, in the criminal justice system are examined. Programs in Australia and other countries utilising these processes will be examined. Issues to be addressed include theoretical implications for the criminal justice system and for sentencing; the rights and needs of victims; drafting a program for a pilot project in NSW; and future directions for victim–offender dispute resolution both in Australia and overseas.

77749**Construction Industry Dispute Resolution**

6cp; 1 semester; {if}{dr}; availability MDR, LLM, SJD, MLS, GCDR, GDLS SUPPLY; prerequisite: 77735 or 79771 Dispute Resolution or demonstrated experience in the field

This subject explores dispute management and resolution in a most dispute prone industry. Procedures developed in Australia and overseas to prevent and manage disputes on construction sites, as well as resolve them, are studied. This industry is recognised as one which has attracted experimentation in resolution processes. The place of formal and informal processes within the industry will be covered.

77751**International Commercial Arbitration**

6cp; 1 semester; {dr}{c}{int}; availability MDR, LLM, SJD, GCDR, MLS, GDLS, SUPPLY; prerequisite: (GPCS, MCS, Supply): Legal Process 72100 or equivalent

Topics in this unit include ad hoc arbitrations; relevant legislation and international conventions; international Institutional Arbitration Associations; scope, formal requirements and validity of agreement to arbitrate; drafting in regard to ICSID arbitrations; curial intervention; compulsory reference of an international commercial dispute to arbitration in Australia; drafting stabilisation and renegotiation clauses; composition of the arbitral tribunal; the language of arbitration; award of damages in

international arbitration; sovereign immunity; international standard construction contracts; power of the international arbitral tribunal to deal with defaults, delaying tactics or refusal of a member to participate in the making of an award; provisions for correcting international commercial arbitration award; recourse against award under the UNCITRAL model law; recognition and enforcement of foreign arbitral award under the UNCITRAL model law and the New York Convention; and liability of the arbitrator for negligence and/or wilful neglect of duty.

Note: This subject cannot be undertaken if 77717/77783 International Commercial Dispute Resolution has already been completed towards the program.

77752**Commercial Arbitration (Domestic)**

6cp; 1 semester; {c}; availability MDR, LLM, SJD, MLS, GDLS, GCDR, SUPPLY; prerequisite: (GPCS, MCS, Supply): Legal Process 72100 or equivalent {dr}

Topics to be covered include the arbitration agreement and its scope; the arbitrator's jurisdiction; reference by the court to a referee or arbitrator; the inherent jurisdiction of the court to interfere in arbitral proceedings; agreement binding on the Crown; the appointment of arbitrators and other related matters; the umpire entering upon the reference; the distinction between an arbitration certification, valuation, assessment, an exception clause, reference to arbitrator, or quasi-arbitrator; powers and duties of the Arbitration Tribunal; subpoenas; evidence; legal representation; amiable compositeur or *ex aequo et bono*; interim awards; specific performance; extension of ambit of arbitration proceedings; duties of parties; right of appeal; exclusion agreements; misconduct; remission of award; removal of arbitrator or umpire; sundry provisions; *Scott v. Avery* Clause; and foreign awards.

77753**Jurisprudence: Aspects of Justice in Modern Legal Systems**

6cp; 1 semester; availability LLM, SJD

Deals with competing theories of justice and of rights in different legal orders. It is an exercise in comparative and cross-cultural thinking in terms of modern applied jurisprudence. Students will be encouraged to confront some theories of justice with the practice of law in various legal traditions. The

fundamental values of law (such as its autonomy, neutrality, certainty and the rule of law) will be examined in the context of competing attitudes to justice: attitudes of the general public, and reasoning of judges in coming to judicial decisions.

77754

Advanced Corporate Insolvency and Restructuring

6cp; 1 semester; {c}; availability LLM, SJD; prerequisite: 77730 Corporate Insolvency and Restructuring

An advanced study of insolvency law and the related issues, with a particular emphasis on trends in, and styles of, formal and informal debt restructuring. Lectures will also analyse case studies to demonstrate the application of legal and commercial principles in a practical context.

77755

Superannuation Law

6cp; 1 semester; {c}; availability TAX, LLM, SJD

Provides an overall understanding of the taxation, legal and industry matters affecting superannuation. Specific topics covered include the history of superannuation; an overview of the current situation; trust deed issues; the legislative framework – ITAA and OSSA, their Regulations, and SGL; and the relationship of superannuation to topical issues such as insolvency, family law, administration companies and surplus.

77756

Copyright Law

12cp; 2 semesters; {jp}; availability LLM, SJD

The principles of copyright, the development of case law, and the structure and ambit of the legislation will be covered. Students will be required to develop a detailed knowledge of the *Copyright Act 1968* as amended, and associated regulations, and to have a comprehensive knowledge of relevant case law.

77757

Advanced Family Law: Proprietary Remedies

6cp; 1 semester; availability LLM, SJD

Provides instruction at an advanced level into the forms of proprietary relief which are available in domestic property disputes. Topics to be covered include statutory principles of

family property relief; principles governing the exercise of judicial discretion and appellate intervention; ascertaining family assets; valuation of assets and financial disclosure; property applications involving trusts and companies; the use of restitution in domestic property applications; enforcement; evidentiary issues in the Family Court; and advanced advocacy.

77758

Private International Law

6cp; 1 semester; {int}; availability LLM, SJD

An advanced study of the principles of private international law as they operate within the Commonwealth of Australia and in relation to overseas countries, with emphasis on issues of current relevance, and with reference to American and European law. In particular, current developments at the Hague Conference on Private International Law and in the European Union will be examined.

77759

International Monetary Law

6cp

The objective of this subject is to provide an overview of international monetary systems and the current legal issues in this area. Topics to be covered include, introduction to the international monetary system, the international monetary institutions, the European monetary system and current legal issues affecting international monetary systems.

77760

Family Dispute Resolution

6cp; 1 semester; {dr}; availability MDR, LLM, SJD, MLS, GDLS, GCDR, SUPPLY; prerequisite: 77735 or 79771 Dispute Resolution or demonstrated experience in the field

This subject covers dispute resolution for family disputes. It will provide a framework for developing both skills in the use of dispute resolution processes within the family court, and a critical evaluation of the use of such techniques. An essential feature of this subject will be the study of the special problems that arise in resolving disputes within families, including power imbalances, gender issues, domestic violence and offences against children and the effect these have on the resolution of family disputes.

77761**Dispute Resolution in Commerce**

6cp; 1 semester; {c}{dr}; availability MDR, LLM, SJD, MLS, GDLS, GCDR, SUPPLY; prerequisite: 77735 or 79771 *Dispute Resolution or demonstrated experience in the field*

This subject will explore the applications of dispute resolution theory and practical skills to the corporate environment. It will explore the causes of conflict within a corporation, and between a corporation and the outside world. The range of dispute resolution processes will be studied to ascertain their relevance and the problems in applying them to the various types of dispute that occur. Students will have the opportunity to study the impediments to changing the dispute resolution culture of an organisation, and they will be encouraged to build models for implementing change in a range of corporate environments. The differences between implementation between the public and private sectors and between different sectors of the corporate/business world will also be explored.

77762**Industrial Dispute Resolution**

6cp; 1 semester; {if}{dr}; availability MDR, LLM, SJD, MLS, GDLS, GCDR; SUPPLY; prerequisite: 77735 or 79771 *Dispute Resolution or demonstrated experience in the field*

This subject will cover the history of industrial dispute resolution in Australia. It will look at the relevance of dispute resolution to the workplace and to the relationship between unions and management. As this latter is a new area for the use of mediation and dispute resolution in Australia, the subject will seek to develop a model process for such dispute resolution, particularly in view of the introduction of enterprise bargaining and the initiative to introduce mediation/dispute resolution into the industrial relations area in NSW. Input from industry will be provided.

77763**Community Dispute Resolution**

6cp; 1 semester; {dr}; availability MDR, LLM, SJD, MLS, GDLS; SUPPLY; GCDR; prerequisite: 77735 or 79771 *Dispute Resolution or demonstrated experience in the field*

The course is planned to consider the nature and development of community dispute resolution both in Australia and overseas. NSW Community Justice Centres collaborate

in its teaching. It will examine concepts of 'community' and 'culture' and the ways in which diverse community values and social change have affected forms of dispute resolution. Some critiques of the philosophy and use of mediation as a form of dispute resolution will be examined. Specific models and applications of community dispute resolution will be considered, including mediation with neighbourhoods, families, workplaces and organisation. The concept and operation of peer mediation programs will be explored, particularly within schools and prisons. Consideration will be given to issues and practices in managing multi-party and large-scale community disputes.

77764**Environmental Dispute Resolution**

6cp; 1 semester; {dr}; availability MDR, LLM, SJD, MLS, GDLS; GCDR; SUPPLY; prerequisite: 77735 or 79771 *Dispute Resolution or demonstrated experience in the field*

This subject studies the use of dispute resolution in environmental disputes and the potential for developing dispute resolution processes in this area. It will also examine the application of dispute resolution processes to planning issues, and matters currently dealt with by the Land and Environment Court of NSW. In developing students' practical skills, the subject will explore strategies that may be used for dispute resolution in multi-party disputes, for policy development and where public interest groups are involved.

77765**Court-based Dispute Resolution**

6cp; 1 semester; {dr}; availability MDR, LLM, SJD, MLS, GDLS; GCDR; SUPPLY; prerequisite: 77735 or 79771 *Dispute Resolution or demonstrated experience in the field*

This subject explores the incorporation of dispute resolution processes into the court system. It draws on programs in courts in Australia and overseas. It addresses the impact of dispute resolution on the formal state-provided dispute resolution system, and examines the interface of the formal and informal systems, and the effect of the informal system on society's norms and on the adversarial system of social control.

77766**Economic Law of the People's Republic of China**

6cp; 1 semester; {int}; availability LLM, SJD

This subject provides an in-depth understanding of China's modernisation program and its interpretation of 'economic law'. Topics include domestic economic contract law; foreign economic contract law; and the traditional Chinese concept of 'contract' versus communist Chinese ideology and pragmatism.

77767**Tax Administration**

6cp; 1 semester; {c}; availability TAX, LLM, SJD

Access to timely and relevant tax-related information is crucial to the ATO's attempts to correctly assess taxpayers and to taxpayers' attempts to resist assessments. The subject analyses critically the rationale for and structure of the current tax administration system, and then proceeds to a detailed analysis of the key strategic elements of that system including tax audits, self-assessment, objections and appeals, and collection and recovery of unpaid tax. Alternatives for reform are also examined.

77769**Advanced European Union Law**

6cp; 1 semester; {c}{int}; availability LLM, SJD; prerequisite: 77704 European Union Law

This subject builds upon 77704 European Union Law to provide an in-depth study of the current position of the European Union (EU) in the world today. The topics to be discussed all involve current issues within the EU or the current issues affecting the EU and other trading blocs. Throughout the subject, the relevance of EU law to the Commonwealth, its economy and legal relations will be explored.

77771**Comparative Law Research Project**

12cp; 2 semesters; availability MCL

In this subject, the student will acquire an understanding of and an ability to apply the principles of the common law, and acquire research skills and methodology in problem solving in international legal practice.

77772**Migration Law**

6cp; 1 semester; availability LLM, SJD

This subject deals with the development of a distinct Australian citizenship, the right to travel and immigration control in Australia. Constitutional law issues, the legislative framework, and the Australian Government's humanitarian and international obligations are covered. Particular topics include the granting of citizenship; passports; statutory concept of entry; refugee status; change of status; deportation; government policy; immigration programs; departmental procedures; administrative discretion; legal institutions; natural justice; criminal offences; legal practice and procedure; and comparative study of immigration control systems.

77773**Planning and Development Law 2: Pollution Control Legislation**

6cp; 1 semester; {c}; availability LLM, SJD

The subject looks at pollution control legislation in NSW and also deals with the relationship between that legislation and the *Environmental Planning and the Method of Assessment Act 1979*. Topics include the granting of development approvals and pollution control licences; the role of State and local government bodies; court remedies available for breaches of pollution legislation; and overlapping Commonwealth and State legislation.

77774**Current Issues in Corporate Law**

6cp; 1 semester; {c}; availability LLM, SJD

This is an advanced study of current developments and central issues in corporate law. Topics include issues in corporate governance and the Corporations Law Simplification Program.

77778**Advanced Computerised Legal Research**

6cp; 1 semester; availability LLM, SJD

This subject analyses existing CD-ROM, online and Internet resources; builds upon existing research skills and develops strategies for integrating computerised legal research; brings students up to date with recent developments in legal information retrieval and associated

technologies; introduces students to specialised systems and products; and aims to enable students to critically evaluate computerised applications to law.

77780

Research Paper (DR)¹

6cp; 1 semester; availability MDR

Candidates in the MDR are required to complete either a Research Paper (DR) or Research Project (DR) as their final subject. The Research Paper (DR) requires the submission of a paper of approximately 8,000–10,000 words which researches an area of alternative dispute resolution. Prior to enrolment, students should consult the Faculty in order to have their topic approved and supervisors appointed by the Faculty's Graduate Studies Committee. All topics and supervisors must be finalised prior to the commencement of the relevant semester – by July for Spring semester and by November for Autumn semester. The Research Paper (DR) is subject to rules approved by the Faculty Board. Copies of these rules are available from the Administrative Secretary (Postgraduate).

This subject **does not satisfy** the Faculty Board's requirements for the awarding of Honours in the MDR. Candidates for Honours in the MDR should enrol in 77781 Research Project (DR).

¹ (DR) = Dispute Resolution

77781

Research Project (DR)

12cp; 2 semesters; availability MDR

Candidates in the MDR are required to complete either a Research Paper (DR) or Research Project (DR) as their final subject. The Research Project (DR) requires the submission of a paper of approximately 15,000–20,000 words which researches an area of alternative dispute resolution. Prior to enrolment, students should consult the Faculty in order to have their topic approved and supervisors appointed by the Faculty's Graduate Studies Committee. All topics and supervisors must be finalised prior to the commencement of the relevant semester – by July for Spring semester and by November for Autumn semester. The Research Project (DR) is subject to rules approved by the Faculty Board. Copies of these rules are available from the Administrative Secretary (Postgraduate). Candidates for Honours in the MDR need to complete this

subject and attain an average mark of at least 75 per cent in their coursework subjects.

77782

Advanced Media Law: Libel Law and Privacy

6cp; 1 semester; {c}; availability LLM, SJD

This is an advanced study of media law that concentrates on the areas of libel law and privacy. It aims to build the student's knowledge of media law and encourage critical analysis. Topics covered include right of privacy, intrusion, publication of private matters, appropriation, libel and slander, traditional defences and libel law reform.

77783

International Commercial Dispute Resolution (S)¹

6cp; 1 semester; {dr}{c}{int}; availability MDR, LLM, SJD, MLS, GDLS, GCDR, SUPPLY

Topics covered include negotiation in international commercial disputes; cross-cultural commercial negotiations; transnational aspects of arbitration; arbitration as contract; statutory regulation of arbitration; international arbitration law; negotiating with Japan and a Middle Eastern country; the role of dispute resolution centres; arbitration institutions; and drafting and analysing arbitration agreements. A compulsory component of the subject is a three-day skills workshop.

Note: This subject **cannot** be taken if 77751 International Commercial Arbitration has already been completed towards the program.

¹ (S) = 6cp version of a 12cp subject

77784

International Business Law

6cp; 1 semester; {int}; availability LLM, SJD

This unit examines aspects of the law of the international sale of goods; aspects of the legal environment of the conduct of business abroad; international economic institutions; Australia and its major trading partners; aspects of the anti-trust legislation and incentives to export; fiscal aspects of trade; the protection of Australian industry; foreign investment law; and the transnational corporation.

77785**Law of Futures and Derivatives***6cp; 1 semester; {c}; availability LLM, SJD*

The objective of this subject is to provide an overall appreciation and understanding of legal matters affecting futures and derivatives products and to a lesser extent the regulation of futures and derivatives. The importance of the use of futures and derivatives products to Australia's business community and the increasing complexity of such products indicate that all business people, whether lawyers or non-lawyers, should have a grasp of the relevant issues.

77786**Private International Air Law***6cp; 1 semester; {int}; availability LLM, SJD*

The purpose of this course will be to analyse the specificity of private law relations arising in international air navigation and air transport, and to study the sources of unified law and the comparative jurisprudence based on them. Law-making trends in view of the crisis of the existing sources of unified law will be examined. The course will be given in a seminar-type setting encouraging discussion.

77789**Law of Prescribed Interests and Collective Investments***6cp; 1 semester; {c}; availability LLM, SJD*

The objective of this subject is to provide an overall appreciation and understanding of legal matters affecting prescribed interests and collective investments and to a lesser extent the regulation of prescribed interests and collective investments. The importance of the use of prescribed interests and collective investments to Australia's business community and the increasing complexity of such products indicate that all business people, whether lawyers or non-lawyers, should have a grasp of the relevant issues.

77792**Crisis Negotiation**

6cp; 1 semester; {dr} {ind}; availability LLM, SJD, MDR, GCDR, MLS, GDLS, SUPPLY; prerequisite: 77735 or 79771 Dispute Resolution or demonstrated experience in the field.

This subject concentrates on the micro-skills of negotiation at an advanced level. It is designed to give students an in-depth

understanding of the skills and techniques used in crisis negotiation, and in dealing with a difficult party. Co-negotiation techniques are also taught with an emphasis on role-play exercises.

77793**Computer Law***6cp; 1 semester; availability LLM, SJD*

This course looks at the current law and its future development to deal with new forms of intellectual property related to computing and electronic data transmission. It looks at the need for management to consider risk management of computer projects. It also looks at the problems posed by computer abuse and fraud for the legal system. It particularly emphasises the importance of law to the development of the high technology and computer industries for the future, both in an international and a national context.

77795**International Business Arbitration: Chinese Perspectives***6cp; 1 semester; availability LLM, SJD*

This subject examines international commercial arbitration in China. Topics include traditional practice, arbitration involving foreign parties, and the practices of the Chinese International Economic and Trade Arbitration Commission.

77796**Taxation of Partnerships and Trusts***6cp; 1 semester; availability LLM, SJD*

This subject will provide a theoretical and practical overview of the taxation of partnerships and trusts and the taxation of partners and beneficiaries in respect of their interests in those entities. The topics include the calculation of net income or losses of partnerships and trusts and the allocation of net income/losses to partners and net income to beneficiaries. The impact of variations in partnership and trust interests and the application of the capital gains tax provisions to dealings with these entities will also be considered.

77799**Advanced Comparative Law for Civil Lawyers***6cp; 1 semester; availability LLM, SJD, MCL*

This is an intensive subject which provides the bridge between the civil law and the common law. It is the compulsory introductory subject for lawyers from countries with civil or dual civil and common law legal systems attempting the LLM, SJD or MCL Programs. It opens with tuition and practical exercises in the research skills and methodology of the common law. The topics covered by Advanced Comparative Law are: primary and secondary sources of the common law; the development of the common law; courts and lawyers; the spread and reception of the common law; law finding in the common law; contract law in the common law; public law and the common law; and business transactions in the common law. The subject also involves visits to the courts and Sydney law offices.

77800**Research Project (LS)***12cp; 2 semesters; availability MLS*

Candidates undertaking the Research Project must research and write a paper of approximately 12,000–15,000 words of a standard suitable for publication on a topic approved by the Faculty. In most cases the Research Project will extend and develop research done in one or more of the MLS subjects already undertaken, but in appropriate circumstances a candidate may undertake a new topic. The Research Project is subject to rules approved by the Faculty Board; copies of the rules are available from the Administrative Secretary (Postgraduate).

77801**International Trade Law (LS)¹***12cp; 1 semester; {c}{int}; availability MLS, GDLS, SUPPLY; prerequisite: 72100 Legal Process or basic knowledge of law*

Topics include the sale of goods; representation overseas; finance; export credits and insurance; carriage of goods; arbitration and litigation; customs law; and international trade regulation.

¹ (LS) = Legal Studies subject.

77802**International Economic Law (LS)***6cp; 1 semester; {c}{int}; availability MLS, GDLS, SUPPLY; prerequisite: 72100 Legal Process or basic knowledge of law*

Designed to develop an understanding of the law governing the international economy and relations between participants in that economy. The concept of international economic law will be examined, and topics will include specific resource issues such as the common heritage; the deep sea bed; Antarctica; international legal regulation of investment, finance and trade; the institutions – IMF, GATT, IBRD; and the relationship between national and international economic law involving such concepts as extraterritoriality and sovereign immunity.

77803**Current Problems of Public International Law (LS)***6cp; 1 semester; {int}; availability MLS, GDLS, SUPPLY; prerequisite: 72100 Legal Process or basic knowledge of law*

Assists students to develop an advanced understanding of the subject, including topics such as recent developments; sources of public international law; dispute resolution; diplomatic immunity; the law of the sea; extradition and asylum; international protection and human rights; treaty practice and procedure; and the recognition of states and governments.

77804**International Business Transactions (LS)***6cp; 1 semester; {c}{int}; availability MLS, GDLS, SUPPLY; prerequisite: 72100 Legal Process or basic knowledge of law*

After an introductory segment dealing with the international trading system including expanded range of matters covered by GATT 1994, the subject is structured to give students an understanding of the law of international contracts for sale of goods at arms length as well as contracts concerning trade through closer business relationships with foreign entities such as joint ventures. Other contractual relationships intertwined with the principal contract for international sale of goods and/or services such as contracts for international carriage of goods and payment mechanisms are covered. Government mechanisms for regulating international trade

between 'private' traders such as the customs regime are discussed. A segment of the course is also devoted to international services trade.

77805

Chinese Trade and Investment Law (LS)

6cp; 1 semester; {c}{int}; availability MLS, GDLS, SUPPLY; prerequisite: 72100 Legal Process or basic knowledge of law

An introduction to the trade and investment law of the People's Republic of China. Topics include the role of law in China; the law-making process and interpretation; legal aspects of China's foreign trade; legal aspects of foreign investment in China; contractual and equity joint ventures and wholly owned foreign enterprises; taxation of foreign interests; foreign exchange control; securities and futures; special Economic Zones; banking and finance; and dispute resolution.

77806

Chinese Law and Legal Systems (LS)

6cp; 1 semester; {int}; availability MLS, GDLS, SUPPLY; prerequisite: 72100 Legal Process or basic knowledge of law

This subject provides a background to further specialist study of contemporary Chinese law, including Chinese commercial law relating to foreign investment, and investigates Chinese communist legal styles, attitudes and structures, as well as traditional imperial Chinese legal attitudes and methods.

77807

Economic Law of the People's Republic of China (LS)

6cp; 1 semester; {int}; availability MLS, GDLS, SUPPLY; prerequisite: 72100 Legal Process or basic knowledge of law

This subject provides an in-depth understanding of China's modernisation program and its interpretation of 'economic law'. The topics studied include domestic economic contract law; foreign economic contract law; and the traditional Chinese concept of 'contract' versus communist Chinese ideology and pragmatism.

77808

Indonesian Trade and Investment Law (LS)

6cp; 1 semester; {c}{int}; availability MLS, GDLS, SUPPLY; prerequisite: 72100 Legal Process or basic knowledge of law

An overview of the legal system of Indonesia, with particular emphasis on trade and investment law. Topics will include the Indonesian legal system; business organisation; joint ventures; securities law; foreign investment; land law; exchange control; and litigation and arbitration.

77809

International Monetary Law (LS)

6cp; 1 semester; {c}{int}; availability MLS, GDLS, SUPPLY; prerequisite: 72100 Legal Process or basic knowledge of law

The objective of this subject is to provide an overview of international monetary systems and the current legal issues in this area. Topics to be covered include, introduction to the international monetary system, the international monetary institutions, the European monetary system and current legal issues affecting international monetary systems.

77811

Deceptive Trade Practices and Product Liability (LS)

12cp; 2 semesters; {c}; availability MLS, GDLS, SUPPLY; prerequisite: 72100 Legal Process or basic knowledge of law

An advanced study of Parts V and VI of the *Trade Practices Act* (and analogous legislation). Topics covered include deceptive trade practices; remedies; unconscionable conduct; and the liability of suppliers, service providers and manufacturers. Emphasis is placed upon recent legal developments.

77812

Restrictive Trade Practices (LS)

12cp; 2 semesters; {c}; availability MLS, GDLS, SUPPLY; prerequisite: 72100 Legal Process or basic knowledge of law

This is an advanced study of the law and recent developments in the area. Where relevant, a comparative analysis will be undertaken and the regulation of competition in the US and the European Union will be studied. The subject will examine the constitutional basis

for the *Trade Practices Act 1974* (Cth), the recent developments to expand the applicability of the Act and the rationale for such regulation from both a lawyer's and an economist's perspective. The specific prohibitions which will be examined include misuse of market power, mergers, collusive conduct, exclusionary conduct, boycotts, exclusive dealing agreements and resale price maintenance. Current topics, including the deregulation of government business enterprises, will also be covered.

77813

Corporate Insolvency and Restructuring (LS)

6cp; 1 semester; {c}; availability MLS, GDLS, SUPPLY; prerequisite: 72100 Legal Process or basic knowledge of law

An advanced study of corporate insolvency law. Topics include the regulating structure; secured and unsecured creditors; reservations; liquidation; schemes of arrangement; official management; the role of directors; and foreign companies and foreign proceedings.

77814

International Commercial Arbitration (LS)

6cp; 1 semester; {int}{com}{dr}; availability MLS, GDLS, SUPPLY

Topics include ad hoc arbitrations; relevant legislation and international conventions; international institutional arbitration associations; scope, formal requirements and validity of agreement to arbitrate; drafting in regard to ICSID arbitrations; curial intervention; compulsory reference of an international commercial dispute to arbitration in Australia; drafting.

77815

Patent Law of Australia (LS)

12cp; 2 semesters; {ip}; availability MLS, GDLS, SUPPLY; prerequisite: 72100 Legal Process or equivalent

Provides candidates with an opportunity to study the current law and practice relating to the protection of intellectual property rights in inventions and technological advances. Topics include confidential information; history of patents for inventions; current legislation and reform; subject matter; right to apply; employees' inventions and joint ownership; form of application; specifications

and fair basing; novelty and obviousness; opposition; grounds of invalidity; Crown use; patents of addition; extensions of term; patent conventions; infringement; licences; assignment; remedies and penalties; and the value of the patent system in the economy.

77816

Design Law (LS)

12cp; 2 semesters; {ip}; availability MLS, GDLS, SUPPLY; prerequisite: 72100 Legal Process or equivalent

A study of the law relating to the registration of designs and an overview of the law of copyright. Topics include the history of registered design legislation; meaning of design; requirements for registration; novelty or originality; registration process; infringement; term; ownership of registered design; rights created by registration; rectification of the register; licences and assignment; compulsory licences; transition provisions; design and copyright overlap; relevance of the *Trade Practices Act 1974*; international obligations; and the *Circuits Layout Act 1988*. The overview of copyright law will encompass a consideration of both works and other subject matter under the *Copyright Act 1968*.

77817

Trademarks Law of Australia (LS)

12cp; 2 semesters; {ip}; availability MLS, GDLS, SUPPLY; prerequisite: 72100 Legal Process or equivalent

The subject comprises a study of the trademark monopoly, trademark protection and practice. Topics include passing off; trade libel; unfair competition; misleading or deceptive trademark conduct under the *Trade Practices Act 1974*; the *Trademarks Act 1955*; right to apply; purposes of registration; distinctiveness; deception and confusion; the possibility of protection for misappropriation rather than confusion; division of the register; defensive registration; certification marks; infringement; assignment; the registered user system; the exploitation of marks; remedies; international conventions and commercial counterfeiting; and trademark jurisprudence.

77818**Franchising Law (LS)**

6cp; 1 semester; {c}; availability MLS, GDLS, SUPPLY; prerequisite: 72100 Legal Process or basic knowledge of law

Aims to acquaint students with the role of franchising in the economy, the strengths and weaknesses of franchising, and the relevant applicable law. Topics will include trade practices and franchising; intellectual property and franchising; dispute resolution between franchisor and franchisee; taxation and stamp duty considerations; and international franchising.

77819**Copyright Law (LS)**

12cp; 2 semesters; {ip}; availability MLS, GDLS, SUPPLY; prerequisite: 72100 Legal Process or equivalent

The principles of copyright, the development of case law, and the structure and ambit of the legislation will be covered. Students will be required to develop a detailed knowledge of the *Copyright Act 1968* and its associated Regulations, and to have a comprehensive knowledge of relevant case law.

77820**Corporations, Finance and Securities (LS)**

12cp; 2 semesters; {c}; availability MLS, GDLS, SUPPLY; prerequisite: 72100 Legal Process or basic knowledge of law

This subject considers a number of topics of current relevance to corporations law, securities law, and corporate finance. The topics covered in the course include takeovers; share buy-backs; the federal company law regime; investigations and related topics; developments in directors' duties; an overview of the financial markets; securitisation; the securities industry; controls on public offerings; criminal and civil sanctions relevant to the securities industry; financial advisers; secured and unsecured finance; corporate and unincorporated joint ventures; leasing; subordination; use of commercial paper as a financing technique; syndication and participation; credit facilities; taxation issues in the context of finance law.

77821**Banking Law (LS)**

12cp; 2 semesters; {c}{int}; availability MLS, GDLS, SUPPLY; prerequisite: 72100 Legal Process or basic knowledge of law

This is an advanced study of banking law concentrating on relations between the bank and its corporate customers. The topics covered include the regulatory framework within which banks operate, the relationship between the bank and the customer, and the activities of banks, including cheques, bills of exchange, foreign currency lending, and secured and unsecured lending.

77822**International Banking and Financial Law (LS)**

6cp; 1 semester; {c}{int}; availability MLS, GDLS, SUPPLY; prerequisite: 72100 Legal Process or basic knowledge of law

An advanced study of monetary systems; monetary obligations; foreign money obligations; the problem of the governing law; sovereign risk; exchange control; covenants; default; and types of finance.

77823**Advanced Corporate Insolvency and Restructuring (LS)**

6cp; 1 semester; {c}; availability MLS, GDLS, SUPPLY; prerequisite: 77813 Corporate Insolvency and Restructuring

An advanced study of insolvency law and related issues, with a particular emphasis on trends in, and styles of, formal and informal debt restructuring. Lectures will also analyse case studies to demonstrate the application of legal and commercial principles in a practical context.

77824**European Union Law (LS)**

12cp; 1 semester; {c}{int}; availability MLS, GDLS, SUPPLY; prerequisite: 72100 Legal Process or basic knowledge of law

The topics which will be discussed in this subject include the activities of the European institutions; the political and economic origins of the EU and its institutional structures (with emphasis on the European Court of Justice); the interrelationship between Community Law and the law of the 15 member States; and the free movement of goods, workers, capital

and services. The subject will concentrate on the emerging transnational protection of social and economic rights and the jurisprudence of the European Court of Justice.

77825

Advanced International Economic Law (LS)

6cp; 1 semester; {c}{int}; availability MLS, GDLS, SUPPLY; prerequisite: 77802 International Economic Law (LS)

Designed to develop an advanced understanding of the law governing the international economy, and the relations between participants in that economy. Aspects of international economic law shall be considered, including the IMF; floating currencies; foreign exchange control law and international contracts; Article VIII of the IMF; aspects of international fiscal law; the European monetary system; sovereign debt problems; and Eurocurrency markets.

77826

European Union Anti-Trust Law (LS)

6cp; 1 semester; {c}{int}; availability MLS, GDLS, SUPPLY; prerequisite: 72100 Legal Process or basic knowledge of law

Designed to provide an understanding of the provisions of Articles 85 and 86 of the Treaty of Rome, with a brief survey of their relationship to one of the member states of the European Union (normally the UK).

77827

Economic Law in Eastern Europe (LS)

6cp; 1 semester; {c}{int}; availability MLS, GDLS, SUPPLY; prerequisite: 72100 Legal Process or basic knowledge of law

Topics include the functions of law in Eastern Europe; the legal environment of business; privatisation and re-privatisation policy and its legal forms; aspects of company law; banking law; taxation systems; anti-trust legislation; insurance and reinsurance; securities markets; foreign investment laws; the EU and association agreements; OECD and 'Partners in Transition'; aspects of contracts in corporate business; and dispute resolution processes.

77828

Private International Law (LS)

6cp; 1 semester; {int}; availability MLS, GDLS, SUPPLY; prerequisite: 72100 Legal Process or basic knowledge of law

An advanced study of the principles of private international law as they operate within the Commonwealth of Australia and in relation to overseas countries, with emphasis on issues of current relevance, and with reference to American and European law. In particular, current developments at the Hague Conference on Private International Law and in the European Union will be examined.

77829

Advanced European Union Law (LS)

6cp; 1 semester; {c}{int}; availability MLS, GDLS, SUPPLY; prerequisite: 77824 European Union Law (LS)

This subject builds upon 77824 European Union Law to provide an in-depth study of the current position of the European Union (EU) in the world today. The topics all involve the current issues within or affecting the EU and other trading blocs. Throughout the subject, the relevance of EU law to the Commonwealth, its economy and legal relations will be explored.

77830

Maritime Law (LS)

12cp; 2 semesters; {c}{int}; availability MLS, GDLS, SUPPLY; prerequisite: 72100 Legal Process or basic knowledge of law

This subject is divided into two main areas – admiralty law and the law pertaining to the carriage of goods by sea. In both cases, reference will be made to pertinent international conventions and their adoption (or otherwise) in Australia, as well as to current international deliberations. Within the first main group of topics, the areas of admiralty law studied include safety; registration, nationality and ownership of ships; sale and purchase of ships; securities (mortgages and maritime liens); admiralty jurisdiction; collisions and limitation of liability; salvage, towage and pilotage; and maritime employment. The second main group of topics examines the regulation of shipping conferences, and the rights and obligations of parties to contract for the carriage of goods by sea (carrier and shipper), with special reference to charter parties and bills of lading. The areas

studied include anti-trust laws; the Hague; Hague-Visby and Hamburg Rules; sea-worthiness and the duty to take care of cargo; and demurrage, general average, freight and marine insurance. Problems associated with inter-modal transport operations will also be discussed.

77831

Air Law (LS)

6cp; 1 semester; {c}{int}; availability MLS, GDLS, SUPPLY; prerequisite: 72100 Legal Process or basic knowledge of law

This subject is dealt with at both the international and domestic levels. The topics considered include the regulation and organisation of aviation (including sovereignty); the system of carrier liability with emphasis on the Warsaw system; third-party liability (including damage caused to third parties on surface, environmental damage and aviation products liability); aviation insurance and security issues.

77832

Admiralty Law (LS)

6cp; 1 semester; {int}; availability MLS, GDLS, SUPPLY; prerequisite: 72100 Legal Process or basic knowledge of law

This subject gives students an appreciation of public and private international law aspects of maritime commerce and transportation, while ensuring a knowledge of the Australian law governing the relevant areas selected for study. Reference will be made to pertinent international conventions and their adoption (or otherwise) in Australia, as well as to current international deliberations. Topics to be studied include maritime safety; registration; nationality and ownership of ships; securities (mortgages and maritime liens); admiralty jurisdiction; collision and limitation of liability; salvage, towage and pilotage; and maritime employment.

77833

Carriage of Goods by Sea (LS)

6cp; 1 semester; {int}; availability MLS, GDLS, SUPPLY; prerequisite: 72100 Legal Process or basic knowledge of law

This subject examines the regulation of shipping conferences, and the rights and obligations of parties to contract for the carriage of goods by sea (carrier and shipper), with special reference to charter parties and bills of lading.

77834

Advanced Administrative Law (LS)

12cp; 2 semesters; availability MLS, GDLS, SUPPLY; prerequisite: 72100 Legal Process or basic knowledge of law

Topics include major developments in the common law and in federal administrative law. Particular attention will be paid to developing forms of remedies, the alternative forms of review of administrative action through, for example, the Ombudsman, and current issues and prospective developments. Administrative law is relevant to all forms of government activity, including regulation of trade and commerce.

77835

Planning and Development Law I (LS)

6cp; 1 semester; {c}; availability MLS, GDLS, SUPPLY; prerequisite: 72100 Legal Process or basic knowledge of law

Topics in this subject include government involvement in the planning and development process as developer and as intervener; executory discretions in the development process; individual participation in the planning process; review of decisions; a case study for the interaction between private rights and public interests; a case study for the interaction of planning law and environmental concerns; and recent developments.

77836

Planning and Development Law 2: Pollution Control Legislation (LS)

6cp; 1 semester; {c}; availability MLS, GDLS, SUPPLY; prerequisite: 72100 Legal Process or basic knowledge of law

The subject looks at pollution control legislation in NSW. Topics include the granting of development approvals and pollution control licences; the role of State and local government bodies; court remedies available for breaches of pollution legislation; and overlapping Commonwealth and State legislation.

77837

Tax Procedures, Sales Tax and Stamp Duties (LS)

12cp; 2 semesters; {c}; availability MLS, GDLS, SUPPLY; prerequisite: basic knowledge of tax law

The topics covered include the Commissioner's powers to obtain information; imputation of tax; administrative law and tax;

tax avoidance; tax appeals and objections; sales tax; and stamp duties.

77838

Capital Gains Tax (LS)

12cp; 2 semesters; {c}{t}; availability MLS, GDLS, TAX, SUPPLY; prerequisite: basic knowledge of tax law

This subject involves an in-depth study of capital gains tax (CGT) including consideration of legislative amendments since the introduction of CGT. Most of the first semester will be spent covering the CGT fundamentals such as the meaning of assets, acquisition and disposal, cost base and consideration. The second semester will consider the application of CGT in special circumstances, such as for companies, trusts and partnerships as well as the international implications.

77839

Superannuation Law (LS)

6cp; 1 semester; {c}; availability MLS, GDLS, SUPPLY; prerequisite: basic knowledge of tax law

Provides an overall understanding of the taxation, legal and industry matters affecting superannuation. Specific topics covered include the history of superannuation; an overview of the current situation; trust deed issues; the legislative framework – ITAA, OSSA and regulations, and SGL; and the relationship of superannuation to topical issues such as insolvency, family law, administration companies and surplus.

77840

Tax Administration (LS)

6cp; 1 semester; {c}; availability MLS, GDLS, SUPPLY

Access to timely and relevant tax-related information is crucial to the ATO's attempts to correctly assess taxpayers and to taxpayers' attempts to resist assessments. The subject analyses critically the rationale for and structure of the current tax administration system, and then proceeds to a detailed analysis of the key strategic elements of that system including tax audits, self-assessment, objections and appeals, and collection and recovery of unpaid tax. Alternatives for reform are also examined.

77841

Advanced Constitutional Law (LS)

12cp; 2 semesters; availability MLS, GDLS, SUPPLY; prerequisite: 72100 Legal Process or basic knowledge of law

Constitutional law is at the heart of the Australian legal system. This course will cover major developments in constitutional law, focusing on current issues. This course will also encourage students to consider the broader context of constitutional law (e.g. social, economic, cultural and political) and will introduce students to various theoretical perspectives, such as feminism and comparative viewpoints.

77845

International Law, the Environment and Technological Change

12cp; 1 semester; {int}; availability GDLST, GCLST, MLS, GDLS, SUPPLY

This subject is designed to develop an understanding of the international dimension of legal issues. The nature and function of the global environment will be examined in the context of legal institutions and their effectiveness for exercising control over the conservation of natural resources. There will also be a consideration of the need to evaluate and assess the legal resources required to respond to problems arising from technological change.

77846

World Order and Indigenous Peoples

12cp; 1 semester; {int}; availability GDLST, GCLST, MLS, GDLS, SUPPLY

This subject is designed to develop an understanding of what is meant by world order and the extent to which its perception may be affected by such factors as national events, business interests and humanitarian concerns. Within this context, the roles of indigenous people at a global level will be reviewed. The development of global recognition and how Australia has responded to these international developments will be examined.

77847

Law in Context

12cp; 1 semester; availability GDLST, GCLST, SUPPLY

This subject develops an appreciation and evaluation of the legal system within the

Australian context. Using case studies, the subject examines contemporary Australian law and the relationship between the individual and the state.

77850

Psychology and Dispute Resolution

6cp; 1 semester; prerequisite: 77735 or 79771
Dispute Resolution; availability LLM, SJD, MDR,
GCCDR, MLS, GDLS, SUPPLY

The strategies used in this subject aim to give a firm understanding of the area and then to gradually develop key skills and abilities for effective handling of self and others in the dispute resolution process. To this end students will be encouraged to use what is learnt in a wide range of experiential learning situations and to then explore how these skills and strategies can be used in their own particular situation, either business or personal.

77851

Law and Medicine (LS)

12cp; 2 semesters; availability MLS, GDLS, SUPPLY;
prerequisite: 72100 Legal Process or basic
knowledge of law

This subject deals with the areas of law that interact with the practice and administration of medicine and other health services. It includes medical negligence; consent; medical records; expert medical evidence in criminal cases; the law of medical ethics; and legal aspects of mental health and intellectual disability, including legal capacity and the rights of mentally ill and intellectually handicapped persons generally.

77852

Current Issues in Corporate Law (LS)

6cp; 1 semester; {c}; availability MLS, GDLS,
SUPPLY; prerequisite: 72100 Legal Process or basic
knowledge of law

This is an advanced study of current developments and central issues in corporate law. Topics covered will include issues in corporate governance and the Corporations Law Simplification Program.

77853

Advanced Computerised Legal Research (LS)

6cp; 1 semester; availability MLS, GDLS, SUPPLY;
prerequisite: 72100 Legal Process or basic
knowledge of law

This subject analyses existing CD-ROM, online and Internet resources; builds upon existing research skills and develops strategies for integrating computerised legal research; brings students up to date with recent developments in legal information retrieval and associated technologies; introduces students to specialised systems and products, and aims to enable students to critically evaluate computerised applications to law.

77854

Advanced Media Law: Libel Law and Privacy (LS)

6cp; 1 semester; {c}; availability LMM, SJD, SUPPLY;
prerequisite: 72100 Legal Process or basic
knowledge of law

This is an advanced study of media law that concentrates on the areas of libel law and privacy. It aims to build the student's knowledge of media law and encourage critical analysis. Topics covered include right of privacy, intrusion, publication of private matters, appropriation, libel and slander, traditional defences and libel law reform.

77855

Law of Futures and Derivatives (LS)

6cp; 1 semester; {c}; availability MSL, GDLS,
SUPPLY; prerequisite: 72100 Legal Process or basic
knowledge of law

The object of this subject is to provide an overall appreciation and understanding of legal matters affecting futures and derivatives products and to a lesser extent the regulation of futures and derivatives. The importance of the use of futures and derivatives products to Australia's business community and the increasing complexity of such products indicate that all business people, whether lawyers or non-lawyers, should have a grasp of the relevant issues.

77856**Private International Air Law (LS)**

6cp; 1 semester; {int}; availability MLS, GDLS, SUPPLY; prerequisite: 72100 Legal Process or basic knowledge of law

The purpose of this course will be to analyse the specificity of private law relations arising in international air navigation and air transport, and study the sources of unified law and the comparative jurisprudence based on them. Law-making trends in view of the crisis of the existing sources of unified law will be examined. The course will be given in a seminar-style setting encouraging discussion.

77858**Law of Prescribed Interests and Collective Investments (LS)**

6cp; 1 semester; {c}; availability LLM, SJD, SUPPLY; prerequisite: 72100 Legal Process or basic knowledge of law

The objective of this subject is to provide an overall appreciation and understanding of legal matters affecting prescribed interests and collective investments and to a lesser extent the regulation of prescribed interests and collective investments. The importance of the use of prescribed interests and collective investments to Australia's business community and the increasing complexity of such products indicate that all business people, whether lawyers or non-lawyers, should have a grasp of the relevant issues.

77859**Computer Law (LS)**

6cp; 1 semester; availability MLS, GDLS, SUPPLY

The course looks at the current law and its future development to deal with new forms of intellectual property related to computing and electronic data transmission. It looks at the need for management to consider risk management of computer projects. It also looks at the problems posed by computer abuse and fraud for the legal system. It particularly emphasises the importance of law to the development of the high technology and computer industries for the future both nationally and internationally.

77861**International Business Arbitration: Chinese Perspectives (LS)**

6cp; 1 semester; availability MLS, GDLS, SUPPLY, MDR, GCDR

This subject examines international commercial arbitration in China. Topics include traditional practice, arbitration involving foreign parties, and the practices of the Chinese International Economic and Trade Arbitration Commission.

77862**Indigenous Context of Australian Law**

6cp; 1 semester; availability MLS, GDLS, SUPPLY

This subject is intended to introduce students to the theoretical questions relating to the notion of law within the indigenous context. By incorporating a historical approach, students will examine the interaction between Aboriginal and Torres Strait Islander people and the developing Australian legal system.

77863**Indigenous Dispute Resolution**

6cp; 1 semester; availability MLS, GDLS, SUPPLY

This subject provides an introduction to the theoretical and practical aspects of this rapidly developing area of Australian law. It is designed to give an overview of the processes of dispute resolution within the Aboriginal and Torres Strait Islander context.

77864**Indigenous Land Rights – A Comparative and International Perspective**

6cp; 1 semester; availability MLS, GDLS, SUPPLY

This subject examines the development of Aboriginal and Torres Strait Islander land rights leading to the enactment of indigenous land rights legislation in the last 25 years. It incorporates an examination of the approach of other common law jurisdictions with regard to indigenous land rights.

77865**Introduction to Taxation Law**

6cp; 1 semester; availability MLS, GDLS, MBA, SUPPLY

The subject provides an introduction to fundamental concepts and the basic structure of taxation in Australia. Emphasis is on the key

concepts of income and deductions, and the subject explores practical application of these concepts to individuals, companies, trusts and partnerships. The subject also introduces specific regimes including CGT, FBT, and international taxation. Tax avoidance, administration and other current topics will also be addressed.

77866

Taxation of Partnerships and Trusts (LS)

6cp; 1 semester; availability MLS, GDLS, SUPPLY

This subject will provide a theoretical and practical overview of the taxation of partnerships and trusts and the taxation of partners and beneficiaries in respect of their interests in those entities. The topics include the calculation of net income or losses of partnerships and trusts and the allocation of net income/losses to partners and net income to beneficiaries. The impact of variations in partnership and trust interests and the application of the capital gains tax provisions to dealings with these entities will also be considered.

UNDERGRADUATE SUPPLY SUBJECTS

The following subjects are offered in the Faculty of Law's Supply program. All units are of one semester's duration. The prerequisite for all law units offered in the Business degree is at least 79202 Business Law. Additional prerequisites for some advanced units are required. For units offered in the Nursing degree, the prerequisite is 79003 Health Law. Not all subjects are offered every semester, and not all subjects are offered on both the City and Kuring-gai campuses.

79001

Legal Issues and Disadvantaged Groups

3cp; elective

This unit aims to assist nurses working with disadvantaged groups to act as advocates for their clients, and to give them a sound understanding of the legal framework that supports and protects these groups in the community and hospitals. Particular reference will be made to mental health and anti-discrimination legislation.

79002

Legal Aspects of Human Reproduction and Child Protection

3cp; elective

This elective unit deals with some of society's most contentious topics and the attempt to introduce laws to deal with the dilemmas associated with them. Topics covered include abortion, surrogacy, *in vitro* fertilisation, euthanasia, child abuse and adoption legislation.

79003

Health Care Law

3cp

This subject has been designed for students in the Bachelor of Nursing program to understand the legal framework within which the nursing profession exists. Specifically the subject will focus on professional responsibilities, the concepts of negligence and issues relating to misconduct. Other areas to be covered include AIDS-related issues, drug laws, employment issues, mental health and euthanasia.

79161**Introduction to Insolvency Law**

6cp; prerequisite: 79202 Business Law; Insolvency Law sub-major

The aim of this unit is to introduce students to the history of bankruptcy; the law and practice of bankruptcy; the purposes of bankruptcy legislation; and procedures to be followed. The unit also compares the roles of the trustee in bankruptcy with those of corporate liquidators and the broader issues of insolvency law.

79162**Corporate Insolvency and Administration**

6cp; prerequisite: 79202 Business Law; Insolvency Law sub-major

Topics covered in this unit include administration; proof of debts; mutual credit and set-off; secured creditors; property available to creditors; distribution and priority of debts; corporate insolvency (winding up); and voluntary administration.

79202**Business Law**

4cp; core

This subject introduces students to the fundamental requirements of law in the contemporary business environment. Every aspect of business is now regulated by legislation and case law. All business decisions will naturally have a legal dimension to them and this may involve either a potential civil or criminal liability. Law is a dynamic subject and is constantly changing, thus lifelong skills need to be attained, with a strong emphasis on efficient research. The content focuses on fundamental legal skills followed by solid business applications, such as contract, negligence, trade practices, the environment and others.

79211**Law for Marketing Management**

6cp; prerequisite: 79202 Business Law; Business Law sub-major

The aim of this unit is to provide students with a sound knowledge of the relevant federal and State laws which affect business decisions in the field of marketing and to provide them with an understanding of the complex laws regulating marketing activities. Topics include

consumer protection; product liability; product safety and standards; intellectual property; the regulation of competition; and risk assessment and compliance strategies.

79264**Securities Market Regulation**

6cp; prerequisites: 79202 Business Law and 79365 Company Law; Taxation Law sub-major; Business Law sub-major

The objectives of this unit are to develop an understanding of the regulatory legal and financial nature of securities markets including the process of regulation and the various players involved, and an understanding of the different theoretical frameworks within which regulations can be analysed. Topics include the process of regulation; the role of the legal regulators; the role of ethics upon the market; regulatory theories; market manipulation; insider trading; takeovers; information disclosure; and creative accounting.

79270**Industrial and Labour Law**

6cp; prerequisite: 79202 Business Law; Business Law sub-major; Employment Relations sub-major

The aim of this unit is to provide students with an awareness and understanding of the legal background to employer/employee relations and the industrial system as it operates, and is changing, within Australia. Topics include industrial tribunals; awards; industrial action; trade unions and employer organisations; collective bargaining; and workers' compensation.

79360**Insurance Contracts**

6cp; prerequisite: 79202 Business Law; Business Law sub-major

This unit will enable students to develop an understanding of the common law principles governing the enforceability of contracts, remedies for breach, termination and the law of agency; the changes effected by the principles associated with the drafting of insurance policy documentations; and the impact that provisions of the *Insurance Contracts Act* have on this process.

79365**Company Law**

6cp; prerequisite: 79202 Business Law; Accounting major; Business Law sub-major

This unit is designed to provide students with a sound understanding of fundamental aspects of company law as it applies to the modern business corporation. Topics include incorporation; corporate constitution; promotion and pre-incorporation; company membership; duties of controlling shareholders; the raising of equity and debt; companies in difficulty; accounts and audit; reorganisation; takeovers; and investigations.

79366**Banking Law**

6cp; prerequisite: 79202 Business Law; Business Law sub-major; Banking major

This unit aims to provide students with an understanding of the manner in which banking institutions are regulated, dealing with the changes following the deregulation of banking. Topics include a historical introduction to the law relating to banking; the statutory regulation of banking; the banker-customer relationship; negotiable instruments; and the provision of loans and other banking facilities.

79370**Law and Contracts**

3cp; prerequisite: 48074 Engineering Communication and Documentation; Bachelor of Technology

This unit aims to familiarise the student with the Australian legal framework, the sources of commercial engineering law in Australia and the responsibilities of engineers in an industrial environment, and to prepare the student for the procedures and processes of operating and negotiating contractual matters as a client, consultant or contractor. Topics include an introduction to Australian law; elements of engineering contracting including the contract life cycle; contract organisation; application of quality assurance; occupational safety and security; environmental protection; product liability; intellectual property; and principles of employment contracts.

79371**Legal Issues in Telecommunications**

6cp; Bachelor of Engineering in Telecommunications Engineering

This unit introduces students to the legal context of telecommunications and information technology in Australia and internationally, and develops students' understanding of the interplay between technical, commercial and legal aspects of introducing a new product or service, and in particular how the regulatory structure shapes market opportunities. Topics to be covered include contract law; product liability; professional liability; intellectual property law; patents; privacy; and consumer rights.

79403**Law and the Manager**

6cp; prerequisite: 79202 Business Law; Business Law sub-major

This unit attempts to apply a selective number of legal topics to areas of interest to both public and private sector managers and aims to highlight a range of legal situations that directly affect managers. Topics covered include employment law; decision making and the legal consequences of decisions; administrative law; alternative dispute resolution; and intellectual property, computers and the law.

79404**Law for Third Sector Managers**

6cp; prerequisite: nil

This subject is designed to introduce a basic understanding of the many strands of law that affect community managers in their work. An introduction to the legal system will be followed by consideration of areas of contract, company, taxation, employment and tort law which are relevant to community managers.

79411**Advanced Companies and Securities Law**

6cp; prerequisites: 79202 Business Law and 79365 Company Law; Taxation Law sub-major; Business Law sub-major; Professional Accounting Practice sub-major

As an advanced elective unit, the aim is to examine in depth certain selected topics, with an emphasis on the practical and comprehensive treatment of topical areas, and to develop an understanding of the operations

of the securities market and the Australian Securities Commission. Topics could include the following: the areas regulated by the *Corporations Law*; securities regulation; the broker/client relationship; the control of improper activities relating to takeovers; investigation and market manipulations; and the simplification reform program.

79462

Revenue Law

6cp; prerequisite: 79202 Business Law; Accounting major; Business Law sub-major

This unit aims to develop students' conceptual and analytical skills and an appreciation of law as a strategic business tool. It concentrates on a study of the Australian income tax system including the *Income Tax Assessment Act*. Topics include the concepts of income and capital, assessable income, allowable deductions, capital gains tax, fringe benefits tax, tax accounting, trusts, partnerships and anti-avoidance.

79502

Law and Finance

6cp; prerequisite: 79202 Business Law; Business Law sub-major

In this unit, students are introduced to a number of relevant aspects of law relating to private sector financing, an area of law that has undergone dramatic changes over recent years, becoming more sophisticated, complex and diverse. Topics could include an evaluation of the different methods of secured and unsecured financing, liability for financial advice, taxation aspects of financing and financial restructuring.

79603

International Business Law and Regulation

6cp; prerequisite: 79202 Business Law; International Business major; Business Law sub-major

Students are introduced to those legal rules that most directly affect traders doing business where there is an international element involved. The unit focuses on matters relating to the formation of contracts in international business transactions, municipal and international regulation of such transactions, resolution of disputes with regard to contracts, and international tortious liability.

79606

Advanced Revenue Law

6cp; prerequisites: 79202 Business Law and 79462 Revenue Law; Taxation Law sub-major; Professional Accounting Practice sub-major

Advanced Revenue Law is an elective unit building on the principles developed in Revenue Law. The aim of the unit is to consider issues that are topical, controversial and important. Because of this, the content and style of the unit will change from year to year, reflecting developments and changed emphases. Topics could include capital gains tax, fringe benefits tax and salary packaging, taxation of retirement payments and superannuation funds, liability for professional negligence, tax ethics and tax agents.

79659

Advanced Commercial Law

6cp; prerequisite: 79202 Business Law; Business Law sub-major

Students are taught to develop a knowledge of business contractual obligations and their application to specific transactions. Topics include sale of goods; consumer protection; product liability; negligence; trusts; partnerships; agency; insurance; credit; negotiable instruments; and bankruptcy.

79660

Environmental Law in Business

6cp; prerequisite: 79202 Business Law; Business Law sub-major; Societal and Corporate Issues in Accounting sub-major

This subject examines environmental law issues as they relate to the business community. Topics covered include international environmental law; ESD; precautionary principle; natural resources management; pollution; waste management; liability of corporate officers; risk management; environmental audits; due diligence; taxes; and tradeable permits.

79662

Business Bankruptcy

6cp; prerequisite: 79202 Business Law; Insolvency Law sub-major

This unit is offered in the Insolvency sub-major and aims to provide students with an appreciation of the requirements for those appointed to act as receivers and managers and to alert students to alternatives to insolvency. Topics include how and why receivers are

appointed, the role of trustees in bankruptcy, and aspects of personal and partnership bankruptcies.

79666

International Aspects of Australian Taxation Law

6cp; prerequisites: 79202 Business Law and 79462 Revenue Law; Taxation Law sub-major; Professional Accounting Practice sub-major

This unit focuses on the offshore aspects of taxation. Although topics would vary from time to time, they could include an analysis of the concept of residence and source of income, the taxation of offshore royalties, the operation of double tax arrangements, and international tax planning.

79667

Indirect Taxation

6cp; prerequisites: 79202 Business Law and 79462 Revenue Law; Taxation Law sub-major; Small Business sub-major

This unit will introduce students to the policy implications raised by direct taxes. It will analyse options for reform and overseas experience with indirect tax systems and examine the basic principles of current indirect taxes in Australia and their practical implications. The topics focus on areas such as payroll tax, sales tax, land tax and stamp duty.

79701

Stamp Duties

6cp; 1 semester; {c}; availability TAX, LLM, SJD, MLS, GDLS, SUPPLY

This unit gives a general overview of stamp duty, the means by which stamp duty is imposed, and the major instruments and transactions that are subject to duty and most frequently encountered in daily practice. Topics to be covered include imposition and territorial nexus; assessment of duty and consequences of non-stamping; conveyances; trusts; Clayton's contracts; goods, wares and merchandise exemption; land-owning companies and trusts; leases; hiring arrangements; loan securities; insurance; and financial institutions duty.

79702

Land Tax and Payroll Tax

6cp; 1 semester; {c}; availability TAX, MLS, GDLS, SUPPLY

This subject is divided into two components. The first component, land tax, canvasses basic principles and more complex legal issues, including general liability, practical aspects and administration and special matters, such as jointly owned land, 'special trusts'. The second component explores complex taxation issues in relation to payroll tax, including issues of general liability; group employers; practical aspects and administration and other special matters such as relevant contracts; and tax concessions.

79703

Legal Aspects of Contracts Administration

6cp; 1 semester; {c}; availability SUPPLY, MLS, GDLS

This subject aims to provide participants with an appreciation of the legal issues that affect the complex contractual arrangements that are a feature of the purchasing and materials management function.

79706

Customs Duties/Levies

6cp; 1 semester; {int}{c}; availability TAX, SJD, LLM, MLS, GDLS, SUPPLY

This unit covers a wide range of substantive customs commercial laws, which have a significant role in the conduct of trade between nations. The international focus of this subject is designed to meet the requirements of students practising either in Australia or overseas. It affords an insight into the application of Customs commercial controls, through a consideration of the underlying principles. The emphasis in the subject is directed to the relevant public international law, which is at the root of Customs administration. The practical application of anti-dumping and countervailing measures through Australian domestic laws will be referred to by way of example. A similar approach is also adopted when considering the questions of the valuation of imported goods, the application of the harmonised commodity classification system, and concessional entry including a consideration of preference and origin rules. There is also a discussion of the electronic information systems, the Customs

audit process and appeal provisions. Reference is made to a number of other matters of relevance to the collection of duties and to the import and export of goods. The subject is interdisciplinary and will involve the discussion and practical application of economic, accounting and legal concepts in the analysis of international trade.

79707

International Taxation 2

6cp; 1 semester; {int}; availability TAX, MLS, GDLS, SUPPLY

International tax planning is one of the key elements in any strategy of expansion. The appropriate tax advice will help avoid pitfalls. This subject will cover issues such as: the tax treatment of non-residents – industry provisions, royalties, sales in Australia by overseas manufacturers and merchants, ex-Australian profits; withholding tax – interpretative provisions, deemed interest, exclusions, recoupment and anti-avoidance legislation, dividends and interest and international tax avoidance; transfer pricing – anti-avoidance legislation, key elements of Division 13, and administrative provisions; among others.

79708

Contemporary Business Law

6cp, 1 semester; {c}; availability MLS, GDLS, SUPPLY

This subject provides students with an understanding of the legal system and a knowledge of a range of legal topics that are of practical relevance to managers. It provides timely information on recent developments in commercial contracts and trade practices legislation, consumer protection, environmental law, intellectual property, employment and anti-discrimination law.

Note: This subject cannot be taken if 72100 Legal Process has already been completed.

79711

Advanced Industrial Law

6cp; 1 semester; {if}; availability SUPPLY, LLM, SJD, MLS, GDLS; prerequisite: 79731 Industrial Law

Develops an understanding of the legal regulation of the employer–employee relationship. Instils an awareness of solutions to problems in this field attempted by other legal systems, and an understanding of current problems. Students develop skills in the

preparation for, and presentation of, cases before industrial tribunals. Seeks to develop an understanding of our industrial arbitration system and the regulation of wages and working conditions under awards at both the federal and State levels.

79718

Advanced Taxation

6cp; 1 semester; {c}; availability TAX, MLS, GDLS, SUPPLY

This subject is concerned with taxation practice. It is not intended to be prescriptive, and variations will be made by the lecturer to cater for the interests of students and to take account of current developments in revenue law. Subjects covered include recent amendments and case law; fundamentals of tax planning; s.51 (1); advanced problems; partnerships; trusts; taxation and stamp duty problems in estate management; company distributions, losses, superannuation and employee benefits; foreign source income and tax havens; alienation of income; legislative and judicial techniques to minimise tax avoidance; objections and appeals; and other revenue laws.

79731

Industrial Law

6cp; 1 semester; {if}; availability SUPPLY, LLM, SJD, MLS, GDLS

Provides an understanding of the matters encompassed by industrial law. The common law and subsequent statute law relating to employer and employee are discussed, and an understanding of the legal regulation of the working conditions and pay of Australian employees at both the Federal and State levels is developed. The parameters of industrial law, and the employer–employee relationship in both the individual and collective aspect, are analysed in depth.

79733

Companies and Securities Law

6cp; 1 semester; {c}; availability SUPPLY, MLS, GDLS

Explores company law in depth in relation to cases, and provides current information on the field of corporate enterprise. Topics covered include national companies legislation in Australia; ASC policy in practice; reform of company accounting standards; registration of company auditors and liquidators; new

procedures for the registration of charges; promoters' contracts; extended duties of directors and executive officers; and special investigations.

79741

Marketing Legislation in Australia

6cp; 1 semester; {c}; availability SUPPLY, MLS, GDLS

This subject aims to acquaint the student with the major pieces of marketing legislation. Topics covered will include the major consumer legislation in Australia, including the *Trade Practices Act*, *Fair Trading Act*, *Contracts Review Act*, *Consumer Claims Tribunal Act*, and *Door to Door Sales Act*; product liability in Australia; regulation of advertising; trademarks, passing off, copyright and patents; and privacy and credit laws.

79742

International Business Law

6cp; 1 semester; availability SUPPLY, MLS, GDLS; prerequisite: knowledge of international business law

This unit examines aspects of the law of the international sale of goods; aspects of the legal environment of the conduct of business abroad; international economic institutions; Australia and its major trading partners; aspects of the anti-trust legislation and incentives to export; fiscal aspects of trade; the protection of Australian industry; foreign investment law; and the transnational corporation.

79749

Law for Managers – Administration

6cp; 1 semester; availability SUPPLY, MLS, GDLS

The course focuses on the legal authority for administrative acts and the accountability of administrators for their acts and decisions. The aim of the course is to provide a basic account of the institutions and legal principles important in administrative law.

Note: This subject cannot be taken if 79794 Legal Issues for Community Managers or 79793 Law for Managers - Health has been completed.

79752

Employment Legislation

6cp; 1 semester; {if}; availability SUPPLY, LLM, SJD, MLS, GDLS; prerequisite: 79731 Industrial Law

This subject considers in detail the main aspects of Australian and NSW employment legislation, together with special legislation concerning leave with pay, workers' compensation, occupational health and safety, and anti-discrimination. A special component of this subject is the study of the legislation and common law affecting industrial disputes.

79753

Current Issues in Industrial Law

6cp; 1 semester; {if}; availability SUPPLY, LLM, SJD, MLS, GDLS; prerequisite: 79731 Industrial Law

This subject focuses on current developments and central issues in industrial relations law, and ensures that students are familiar with current knowledge and practice in the field. Topics include current legislative changes and proposed changes, common law development, and recent arbitration and judicial decisions.

79760

Applied Legal Research

6cp; 1 semester; availability TAX

This subject is provided for those with basic researching skills associated with Australian domestic law, but who have had no exposure to the law of some of our major trading partners and international law. Topics covered will include a revision of Australian primary sources; primary and secondary sources of the UK, America, Canada, New Zealand and the European Union; and aspects of international law, including customary law, treaties, the International Court of Justice and international law organisations.

79762

International Taxation I

6cp; 1 semester; {int}; availability TAX, MLS, GDLS, SUPPLY

A comprehensive explanation of the important issues within the international environment of business is provided. The subject will place emphasis on the more important taxation issues, and will respond to new issues as they arise.

79763**Contemporary Issues in Taxation**

6cp; 1 semester; {c}; availability TAX, MLS, GDLS, SUPPLY; prerequisites: 79718 Advanced Taxation or demonstrated experience in the field

This subject examines key current issues in taxation within the Australian environment. As emphasis is placed on important contemporary issues, the subject content and presentation may vary in order to respond to changes in legislation and practice.

79764**Taxation Project**

12cp; 2 semesters; availability TAX

79771**Dispute Resolution (S)**

6cp; 1 semester; {if}{dr}; availability SUPPLY, GLDR, MLS, GDLS

An introduction to the theoretical and practical aspects of this newly developing area which is applicable to all professions, business and government. It is designed to give an overview of the mediation process, dispute prevention, dispute management and dispute systems. It will provide instruction in dispute system design. Dispute resolution theory is introduced together with the background to the mediation movement and negotiation theory, communication skills and critiques of ADR. A compulsory component of the course is a four-day mediation training workshop.

79781**Readings in International Business Law**

6cp; 1 semester; {int}; availability SUPPLY, MLS, GDLS; prerequisite: 79742 International Business Law or demonstrated equivalent knowledge

Formal lectures in selected areas may be required, as directed by the coordinating lecturer. This subject allows a degree of flexibility in programming for specialised needs of individual students.

79791**Business Law Project**

6cp; 1 semester; availability SUPPLY

Students undertaking the Business Law Project will write and present a formal project on an aspect of the law relating to business. There will be no formal lectures. Students will select

a topic in consultation with the Director of Postgraduate Programs and will be individually supervised.

79792**Taxation Paper**

6cp; 1 semester; availability TAX

79793**Law for Managers – Health**

6cp; 1 semester; availability MLS, GDLS, SUPPLY

Topics to be covered include introduction to the legal system; constitutional aspects; the nature of legal rules; the legislative framework for actions against the public or community managers (e.g. tort, contract); administrative law; particular aspects of law relating to public employment; and the employment of professionals in a health environment.

Note: This subject cannot be taken if 77794 Legal Issues for Community Managers or 79749 Law for Managers – Administration has been completed.

79794**Legal Issues for Community Managers**

6cp; 1 semester; availability MLS, GDLS, SUPPLY

Topics to be covered include introduction to the legal system; constitutional aspects; the nature of legal rules; the legislative framework for actions against public or community managers (e.g. tort, contract); particular aspects of law relating to public employment; the employment of professionals; aspects of the law concerning legal forms available for community organisations; and the tax treatment and responsibilities of boards of managers and trustees.

Note: This subject cannot be taken if 79793 Law for Managers – Health or 79749 Law for Managers – Administration has been completed.

79811**Taxation Module**

6cp; 1 semester; Professional Year; availability TAX

Incorporates the topics specified in the study guidelines issued by the Institute of Chartered Accountants in Australia for candidates who are undertaking the Professional Year examination.

Note: Students must be concurrently enrolled in the taxation module of the professional year at the Institute of Chartered Accountants.

79990

Legal System

4cp

This subject will provide the student of forensic science with an understanding of the law and legal system.

79991

Forensic Science Case Study

6cp

Students will receive training in the preparation of reports and in the presentation of evidence in court. A substantial component of this subject is a moot court.

SUBJECTS OFFERED BY OTHER FACULTIES

22730

Advanced Audit and Computer Security

6cp; 1 semester; availability TAX

Examines the objectives of computer security and controls, and the application of auditing techniques to verify the adequacy of such security and controls. Topics considered include the use of communication networks, and cryptographic security for safeguarding the integrity of computer systems.

22751

Corporate Accounting Issues

6cp; 1 semester; availability TAX

Examines the issues surrounding the provision of corporate reports to external users. Topics considered include the role of a conceptual framework of financial reporting, the role of financial reporting in promoting the efficient allocation of scarce resources, corporate social responsibility in accounting, and the 'public interest' role of accountants.

22760

Applied Research Skills

6cp; 1 semester; availability TAX

Reviews univariate statistical techniques and introduces students to multivariate statistical techniques. Topics covered include experimental studies and analysis of their data, and computerised databases in Australia and their information content.

22810

Accounting Module 1

6cp; 1 semester; Professional Year; availability TAX

This subject incorporates the topics specified in the study guidelines issued by the Institute of Chartered Accountants (ICA) in Australia for candidates undertaking the Professional Year examination. Students need to be concurrently enrolled at UTS and the ICA.

22812

Accounting Module 2

6cp; 1 semester; Professional Year; availability TAX

This subject incorporates the topics specified in the study guidelines issued by the Institute of Chartered Accountants (ICA) in Australia for candidates undertaking the Professional Year examination. Students need to be concurrently enrolled at UTS and the ICA.

Alphabetical list of subjects

Accounting Module 1	22810	Air Law	77718
Accounting Module 2	22812	Air Law (LS)	77831
Administration of Criminal Justice	76004	Applied Legal Research	79760
Administrative Law	70617	Applied Research Skills	22760
Admiralty Law	77736	Australian Indigenous Customary Law – Incorporating Indigenous Land Issues	76703
Admiralty Law (LS)	77832	Banking Law	77715
Advanced Administrative Law	76061	Banking Law	79366
Advanced Administrative Law	77706	Banking Law (LS)	77821
Advanced Administrative Law (LS)	77834	Biomedical Law and Bioethics	76070
Advanced Audit and Computer Security	22730	Business Bankruptcy	79662
Advanced Commercial Law	79659	Business Law	79202
Advanced Companies and Securities Law	79411	Business Law Project	79791
Advanced Company Law	76028	Capital Gains Tax	77719
Advanced Comparative Law for Civil Lawyers	77799	Capital Gains Tax (LS)	77838
Advanced Comparative Law – The Common Law	77742	Carriage of Goods by Sea	77737
Advanced Computerised Legal Research	77778	Carriage of Goods by Sea (LS)	77833
Advanced Computerised Legal Research (LS)	77853	Children and the Law	76066
Advanced Conflict of Laws	76059	Chinese Law and Legal Systems	77733
Advanced Constitutional Law	76060	Chinese Law and Legal Systems (LS)	77806
Advanced Constitutional Law	77707	Chinese Trade and Investment Law	77729
Advanced Constitutional Law (LS)	77841	Chinese Trade and Investment Law (LS)	77805
Advanced Contracts	76047	Citizenship and Immigration Law	76048
Advanced Corporate Insolvency and Restructuring	77754	Commercial and Estate Practice	75403
Advanced Corporate Insolvency and Restructuring (LS)	77823	Commercial Arbitration (Domestic)	77752
Advanced Criminal Law	76037	Communications Law	76042
Advanced European Union Law	77769	Community Dispute Resolution	77763
Advanced European Union Law (LS)	77829	Community Legal Research	76069
Advanced Family Law	76044	Companies and Securities Law	79733
Advanced Family Law: Proprietary Remedies	77757	Company Law	79365
Advanced Industrial Law	79711	Comparative Law A	76001
Advanced International Economic Law	77738	Comparative Law B	76003
Advanced International Economic Law (LS)	77825	Comparative Law Research Project	77771
Advanced Legal Accounting	75405	Computer Law	77793
Advanced Legal Drafting	75408	Computer Law (LS)	77859
Advanced Legal Research	77700	Computerised Legal Information Systems	77714
Advanced Media Law	77722	Conflict of Laws	76112
Advanced Media Law: Libel Law and Privacy	77782	Construction Industry Dispute Resolution	77749
Advanced Media Law: Libel Law and Privacy (LS)	77854	Contemporary Business Law	79708
Advanced Mediation	77746	Contemporary Issues in Taxation	79763
Advanced Public Law	76054	Copyright Law	77756
Advanced Remedial Law: Damages	77731	Copyright Law (LS)	77819
Advanced Remedial Law: Equitable Remedies	77732	Corporate Accounting Issues	22751
Advanced Revenue Law	79606	Corporate Insolvency and Administration	79162
Advanced Taxation	79718	Corporate Insolvency and Restructuring	77730
Advanced Taxation Law	76016	Corporate Insolvency and Restructuring (LS)	77813
		Corporate Law	70417
		Corporations, Finance and Securities	77711
		Corporations, Finance and Securities (LS)	77820
		Court-based Dispute Resolution	77765
		Criminal and Civil Law – Indigenous Perspectives	76702

124 ALPHABETICAL LIST OF SUBJECTS

Criminal Law	70217	Indigenous Peoples and the Law	76068
Criminology	76012	Indirect Taxation	79667
Crisis Negotiation	77792	Indonesian Trade and Investment Law	77739
Current Issues in Corporate Law	77774	Indonesian Trade and Investment Law (LS)	77808
Current Issues in Corporate Law (LS)	77852	Industrial and Intellectual Property	76011
Current Issues in Industrial Law	79753	Industrial and Labour Law	79270
Current Law Reform Proposals – Indigenous Perspectives	76704	Industrial Dispute Resolution	77762
Current Problems of Public International Law	77702	Industrial Law	76053
Current Problems of Public International Law (LS)	77803	Industrial Law	79731
Customs Duties/Levies	79706	Insolvency	76115
Deceptive Trade Practices and Product Liability	76023	Insurance Contracts	79360
Deceptive Trade Practices and Product Liability	77712	International and Comparative Law Project	77710
Deceptive Trade Practices and Product Liability (LS)	77811	International Aspects of Australian Taxation Law	79666
Design Law	77727	International Banking and Financial Law	77724
Design Law (LS)	77816	International Banking and Financial Law (LS)	77822
Dispute Resolution	76052	International Business Arbitration: Chinese Perspectives	77795
Dispute Resolution	77735	International Business Arbitration: Chinese Perspectives (LS)	77861
Dispute Resolution (S)	79771	International Business Law	77784
Dispute Resolution in Commerce	77761	International Business Law and Regulation	79603
Economic Law in Eastern Europe	77743	International Business Transactions	77703
Economic Law in Eastern Europe (LS)	77827	International Business Transactions (LS)	77804
Economic Law of the People's Republic of China	77766	International Commercial Arbitration	77751
Economic Law of the People's Republic of China (LS)	77807	International Commercial Arbitration (LS)	77814
Employment Legislation	79752	International Commercial Dispute Resolution	77717
Environmental Dispute Resolution	77764	International Commercial Dispute Resolution (S)	77783
Environmental Law	76024	International Economic Law	76018
Environmental Law in Business	79660	International Economic Law	77701
Equity and Trusts	70516	International Economic Law (LS)	77802
European Union Anti-Trust Law	77741	International Law and Treaty Obligations, State and Regional Protocols – Indigenous Peoples	76705
European Union Anti-Trust Law (LS)	77826	International Law, the Environment and Technological Change	77845
European Union Law	77704	International Monetary Law	77759
European Union Law (LS)	77824	International Monetary Law (LS)	77809
Family Dispute Resolution	77760	International Taxation	77720
Family Law	76516	International Taxation 1	79762
Family Law and Women's Perspectives – Aboriginal and Torres Strait Islander People	76701	International Taxation 2	79707
Federal Constitutional Law	70616	International Trade Law	76051
Finance Law	76065	International Trade Law	77716
Forensic Science Case Study	79991	International Trade Law (LS)	77801
Franchising Law	77744	Introduction to Insolvency Law	79161
Franchising Law (LS)	77818	Introduction to Taxation Law	77865
Health Care Law	79003	Jessup International Moot	76039
Human Rights	76007	Jurisprudence	76008
In Practice	75409	Jurisprudence: Aspects of Justice in Modern Legal Systems	77753
Indigenous Context of Australian Law	77862	Labour Law	76015
Indigenous Dispute Resolution	76706	Land Dealings	76029
Indigenous Dispute Resolution	77863	Land Tax and Payroll Tax	79702
Indigenous Land Rights – A Comparative and International Perspective	77864	Law and Computers	76014

Law and Contracts	79370	Planning and Development Law 2:	
Law and Finance	79502	Pollution Control Legislation	77773
Law and Medicine	76045	Planning and Development Law 2:	
Law and Medicine	77734	Pollution Control Legislation (LS)	77836
Law and Medicine	77851	Practice and Procedure	71005
Law and Natural Resources	76064	Private International Air Law	77786
Law and the Manager	79403	Private International Air Law (LS)	77856
Law for Managers – Administration	79749	Private International Law	77758
Law for Managers – Health	79793	Private International Law (LS)	77828
Law for Marketing Management	79211	Professional Conduct	75406
Law for Third Sector Managers	79404	Property Transactions	75402
Law in Context	77847	Public International Law	76006
Law of Contract	70211	Psychology and Dispute Resolution	77850
Law of Evidence	71216	Readings in International Business Law	79781
Law of Futures and Derivatives	77785	Real Property	70317
Law of Futures and Derivatives (LS)	77855	Remedies	71116
Law of Insurance	76022	Research Paper	77740
Law of Prescribed Interests and		Research Paper (DR)	77780
Collective Investments	77789	Research Project	77725
Law of Prescribed Interests and		Research Project 4	76040
Collective Investments (LS)	77858	Research Project (DR)	77781
Law of Tort	70311	Research Project (LS)	77800
Legal Accounting and Professional		Restrictive Trade Practices	76027
Responsibility	75404	Restrictive Trade Practices	77721
Legal Aspects of Contracts		Restrictive Trade Practices (LS)	77812
Administration	79703	Revenue Law	76212
Legal Aspects of Human Reproduction		Revenue Law	79462
and Child Protection	79002	Sale of Goods	76411
Legal Issues and Disadvantaged Groups	79001	Securities Market Regulation	79264
Legal Issues for Community Managers	79794	Social Security Law	76062
Legal Issues in Telecommunications	79371	Stamp Duties	79701
Legal Method	76067	Strata Titles and Community Schemes	76017
Legal Process	72100	Succession	76517
Legal Process and History	70113	Superannuation Law	77755
Legal Research	70105	Superannuation Law (LS)	77839
Legal Skills and Advocacy	75400	Tax Administration	77767
Legal System	79990	Tax Administration (LS)	77840
Litigation	75401	Tax Procedures, Sales Tax and Stamp Duties	77713
Local Government Law	76026	Tax Procedures, Sales Tax and	
Maritime Law	77705	Stamp Duties (LS)	77837
Maritime Law (LS)	77830	Taxation Module	79811
Marketing Legislation in Australia	79741	Taxation of Partnerships and Trusts	77796
Media Law	76063	Taxation of Partnerships and Trusts (LS)	77866
Migration Law	77772	Taxation Paper	79792
Moot	76900	Taxation Project	79764
Negotiation	77745	Trademarks Law of Australia	77728
Negotiation Skills	75410	Trademarks Law of Australia (LS)	77817
Patent Law of Australia	77726	Transport Law – Selected Problems	76049
Patent Law of Australia (LS)	77815	Victim–Offender Dispute Resolution	77748
Personal Property	70318	Women and the Law	76046
Planning and Development Law 1	77709	Work Management	75407
Planning and Development Law 1 (LS)	77835	World Order and Indigenous Peoples	77846

Centres within the Faculty

The Australasian Legal Information Institute

The Australasian Legal Information Institute (AustLII) provides free access to Australian legal material to anyone who has access to the Internet. AustLII operates one of the world's largest publicly accessible databases of legal materials on the World Wide Web. AustLII aims to make available all public legal information: primary legal materials (legislation and decisions of courts and tribunals); and secondary materials that are (or ought to be) in the public domain or able to be licensed free of charge.

AustLII's public policy agenda is to convince governments, courts, law reform bodies and other publicly funded organisations to make legal materials they control available free via the Internet. It has an innovative approach to computerising legal materials, based on 10 years' research and development.

Some of AustLII's research features are: automated rich hypertext; development and use of its own search engine (SINO); and integration of hypertext and text retrieval. AustLII's URL is <http://www.austlii.edu.au/>

AustLII is operated jointly by the Faculties of Law at UTS and the University of New South Wales (UNSW). It was established by funding from DEET and the two host universities, and also receives funding from the Australian Research Council, the Law Foundation of NSW, the Australian Business Chamber, the Council for Aboriginal Reconciliation, and other bodies.

Centre for Dispute Resolution

The Centre for Dispute Resolution was established as a joint initiative of the Faculties of Law and Business to promote excellence in teaching, research, development, continuing professional education and consultancy in the emerging discipline of dispute resolution.

The dispute resolution courses which have been developed and presented by the Centre strive to meet the evolving demands and expectations of professional, commercial and government interests as the domestic and international applications of dispute resolution processes become more numerous.

The Centre has been endowed with the first Australian Chair in Dispute Resolution by the law firm Freehill Hollingdale and Page.

The Centre provides teaching for the Master of Dispute Resolution and the Graduate Certificate in Dispute Resolution. These programs are based in the Faculty of Law. Individual dispute resolution subjects are offered to all students enrolled in the Master of Business Administration and to students enrolled in any other postgraduate degree by individual application.

The Centre has enjoyed a successful consultancy program since 1995. In that year the consultancy works included designing dispute resolution systems (particularly for complaints handling) for government departments and private enterprise. A major research project on examining the migration of ADR to small- to medium-sized enterprises was undertaken for the Department of Industry, Science and Technology. The Centre also undertook major consultancies for the State Rail Authority (NSW), to design a grievance-handling procedure, and in 1996 for Transgrid, to design a dispute resolution system that would assist the restructuring of the NSW Electricity Industry.

The Centre continues to carry out consultancy work and to operate as an information centre on dispute resolution for a wide range of people and organisations, both within Australia and overseas. The Centre also sponsors seminars on topical dispute resolution issues. For information concerning the Centre and its services, contact Valda Cooper, telephone 9514 3753, fax 9514 3400.

Community Law and Research Centre

The UTS Community Law and Research Centre was opened in May 1996. The Centre works closely with the Faculty of Law and is under the direction of Associate Professor David Barker, Dean of the Faculty, and a management committee.

The Centre has two vital functions – the provision of free legal services to UTS staff and students, and community legal research. In providing a legal service, the Centre relies on the assistance of law students who volunteer two hours each per week.

The objectives of the legal service include developing effective ways of informing the community of their legal rights and responsibilities, adopting a multidisciplinary approach which recognises that many conflicts require a broader response than strict traditional legal remedies, and initiating and participating in law reform programs.

The legal research function places the Centre at the gateway for community access to the research and academic capabilities of the UTS Law Faculty. It provides metropolitan community organisations with the much-needed legal research expertise in order to respond to proposed law reform, comment on current law and its impact on the community, or generally examine the viability, fairness and importance of law in a particular area. The research function also provides students with important analytical and research skills, which are invaluable in the profession.

From the educational aspect, the Centre provides students with an understanding of the impact of law on particular communities, the dynamics of law reform, community consultations and the impact of politics on the legal system.

It is envisaged that the Centre will enhance the Law Faculty's research strengths and will increase the community's awareness of the University's value and relevance as a service provider.

For information concerning the Centre and its services, contact Peter O'Brien at Blackfriars on the City campus, Blackfriars Street, Chippendale, telephone 9514 2914, fax 9514 2919.

International and Commercial Law Centre

Objectives

The International and Commercial Law Centre (ICLC) maintains close links with the legal profession, the commercial community generally and with the wider international arena. The idea for the Centre evolved from views in the Faculty that there is a role to be filled in assisting, in even a small way, in integrating Australia into the wider Pacific Rim and European regions. In particular, it is felt that such a centre can facilitate the dissemination of knowledge about commercial and international law and foreign legal systems. Achieving these objectives will go some way to establishing Sydney as a major international and commercial centre.

The Centre's activities promote the internationalisation of our legal profession and should ultimately have an impact in creating closer relations with Australia's trading partners. The Centre exports legal knowledge which will help raise Australia's profile in the immediate area and worldwide. It will also perform the much-needed function in Sydney of facilitating the collection and dissemination of knowledge concerning rapidly evolving commercial law areas such as banking and financial law, international taxation, and corporate securities and regulation, and their increasing international implications.

Advisory Board

The Centre is advised by an Advisory Board of eminent lawyers from the private profession, government and the business community. The Centre's Patron is Sir Laurence Street, AC, KCMG. Members of the Advisory Board include nominees of:

Baker & McKenzie

Freehill Hollingdale and Page

Phillips Fox

Mallesons Stephen Jaques

Allen Allen and Hemsley

Minter Ellison

Department of Foreign Affairs and Trade

Commonwealth Attorney-General's

Department

and

Mr Laurie Glanfield, NSW Attorney
General's Department

Professor A J D Blake, Vice-Chancellor, UTS

Professor Sam Blay, Faculty of Law, UTS

Professor David Flint AM, Faculty of Law,
UTS

Mr Geoff Moore, Faculty of Law, UTS

Activities

The Centre publishes the *Australian International Law News* and *Lawasia*, and provides ongoing support to postgraduate programs within the Faculty of Law. The Centre also provides a postgraduate legal education program for lawyers from civil law jurisdictions and arranges visits by eminent international academics to lecture in the area of international or commercial law.

The Centre also sponsors seminars on topical legal issues. As part of its activities the Centre sponsors students to attend Summer and Winter Schools organised and taught by the China University of Political Science and

Law in Beijing. Information is available from Noemi Lemaire on telephone 9514 3154/3155, fax (02) 9514 3156 and email Noemi.Lemaire@uts.edu.au

Sponsorship

The Centre is sponsored by the Faculty of Law of the University of Technology, Sydney, and by corporate sponsors.

The corporate sponsors of Centre activities have included:

Continental Airlines Inc.
Davies Collison Cave
Freehill Hollingdale and Page, Solicitors
Phillips Fox, Solicitors
Qantas Airways Ltd
The Australia–Indonesia Institute
The Australia–China Council
Australia–Japan Trade Law Foundation
The Commonwealth Bank of Australia
The European Union
United Airlines
Ying Tao Pty Ltd

Major sponsorship opportunities are available in connection with the Centre's activities, including sponsorship of specific seminars, workshops, international forums or course programs. These activities attract a high-profile audience and represent valuable sponsorship vehicles.

As a commercially aware organisation, the Centre welcomes sponsorship inquiries from interested parties. Sponsorship inquiries should be directed to the Centre, telephone 9514 3154.

International Institute for Negotiation and Conflict Management

The International Institute for Negotiation and Conflict Management (IINCM) is an independent, nonprofit organisation, created by a consortium of universities. It is located within the Faculty of Law at UTS. IINCM's membership is open to all bodies and individuals interested in negotiation, conflict management and dispute resolution.

The Centre is creating a worldwide network to gather and spread global information about negotiation, conflict management and dispute resolution knowledge, experience, needs and resources, supporting all relevant aspects of education, training, research and consulting.

Education

IINCM works with universities and consultants to develop courses in negotiation, conflict management and dispute resolution. These are usually developed in collaboration with business people, professionals and consultants. The resulting professional packaged courses are offered to IINCM's university and other members. They are supported by comprehensive lecture notes, audiovisual teaching aids, 'train the trainer' programs, visiting lecturer schemes and general technical assistance.

Training

IINCM offers short and long courses in negotiation, conflict management and dispute resolution to non-university (commercial and public) organisations and to individuals through university and other members. Approved courses are accredited by the Institute.

Research and consulting

IINCM is a research and referral resource, building a one-stop information resource database, storage and distribution facility. It refers requests for educational and commercial services in negotiation, conflict management and dispute resolution disciplines on to its members.

Networking

IINCM encourages and assists the creation of local networks based on interaction between university and non-university members.

For more information, contact Garth Brown, Executive Officer, or Melissa Conley-Tyler, Administrator, IINCM, PO Box 123, Broadway, NSW 2007; telephone 9514 3492, fax 9514 3455, email IINCM@law.uts.edu.au

Boards and committees

FACULTY BOARD IN LAW

Composition

Ex officio members

Dean

Professor D Barker (Chair)

Associate Dean

Mr A Mowbray

Professors

Professor S Blay

Faculty Manager

Mr E G Marsh

Nominated members (Two-year terms of office)

Mr P Bebbington, Faculty of Mathematical and Computing Sciences

Ms J English, Law Society of NSW

Dr D Kirkpatrick, Centre for Learning and Teaching

Mr G Lindsay, Bar Association of NSW

Mr F Portelli, Faculty of Business

Associate Professor P Miller, Faculty Board in Science

The Hon. Justice B Sully, Supreme Court of NSW

Ms B Vlies, University Library

Elected members (Two-year terms of office)

Academic Staff

Associate Professor M Adams

Ms K Bubna-Litic

Mr P Chung

Ms R Davis

Mr P Egri

Ms K Gould

Associate Professor P Griffith

Mr G King

Dr D Meltz

Mr G Monahan

Mr G Moore

Ms V Nagarajan

Mrs M Scott

Associate Professor R Watt

Ms J Zetler

Support Staff

Mrs P Williams

Mr P Holt

Elected student members (One-year term of office)

Mr B Burgess

Mr M Huckerby

Ms C Pawliw

Vacant

Official observer

Mr Angus McGinnis, Law Students' Society

FACULTY OF LAW ADVISORY COMMITTEE

Ex officio members

Dean of the Faculty

Associate Professor D Barker

Professor S Blay

External members

The Hon. A Rogers QC (Chair)

Mr R J Bartley AM

Mr G Bugden

His Hon. Judge H Cooper

Ms J English

Ms P Fell

Mr L Glanfield

The Hon. Justice K Lindgren

Ms S McMahon

The Hon. B S J O'Keefe AM QC

Mr R Seidler

Ms D Sharpe

Mr T K Tobin QC

Research interests of staff

The Faculty of Law is located on both the City and Kuring-gai campuses. Staff on the City campus can be contacted through the switchboard number – 9514 2000. The telephone numbers for staff located on the Kuring-gai campus are shown beside their names. All staff are available for consultation during the hours specified on the Law Information Office Noticeboard or Corridor entrance door.

The research interests of each member of staff are listed below.

M A Adams, 9514 5418

Corporate Law, Securities Markets Regulation, Management Law

D Barker, 9514 5414

Access into the Legal Profession, Local Government, Military Law, Waterfront Reform, Clinical Legal Training

S Blay,

International Law, International Environmental Law, Torts, Antarctic Law and Policy, Financial Institutions, Human Rights, International Trade and Arbitration

K Bubna-Litic, 9514 5413

Environmental Law, International Environment Law, Environmental Dispute Resolution, Sustainable Development

S Carr-Gregg

Contracts Law, Insolvency, Legal Education, Bankruptcy, Company Liquidations, Dispute Resolution

T Chiu

International Trade Law, Chinese Investment Law and Constitution, Mediation and Arbitration

J Cooper

Intellectual Property and Entertainment Law, Trade Practices, Administrative Law, Teaching and Learning

P Crofts

Military Law, Legal Narrative Theory, Feminist Theory and Criminology

K Cutbush-Sabine

National and International Business Law, Trade Law, Monetary Law, Company and Contract Law, EEC Law, Securities, Intellectual Property Law

R A Davis

Contracts Law, Insolvency, Legal Education, Bankruptcy, Company Liquidations, Dispute Resolution

J Dobies

Student Motivation, Course Design

P Edmundson

Taxation Law, Corporate Law

P Egri

Computerised Legal Reasoning

L Ellis

Family Law, Pre-Admission Skills and Training, Ecclesiastical Law

I Ellis-Jones

Local Government, Administrative Law, Statutory Interpretation, Discrimination and the Law

M Evans

Equity, Trusts, Law and Medicine, Legal and Constitutional History

D Flint

International Economic Law, Media Law, European Union Law

K Gould

Australian Legal and Constitutional History, English Legal History, the Australian Legal System

P Griffith

Patent Law, Copyright Law, Intellectual Property

D Hipsley

Professional Responsibility, Advocacy

J Hussain

Legal Education, Property, South-East Asian Law, Islamic Law

P Hutchison
Revenue Law, Tax Administration, Tax
Planning, Tax Ethics

P Keyzer
Constitutional Law, Intellectual Property,
Comparative Law, International Law, Law
and Disabilities, Legal Education

J Lancaster, 9514 5480
Law and Medicine, Legal Education,
Discrimination and the Law, Tort Law

M Langford
Ethics, Litigation, Practice and Procedure,
Practical Legal Training

T Libesman
Indigenous People and the Law, Legal
Education

P Lothian
Trade Practices, Civil Litigation Process,
Evidence, Local Government and Town
Planning

D Meltz, 9514 5107
Trade Practices, Private International Law,
The Law and Community Organisations

G Moore
Deceptive Trade Practices, Remedies, Real
Property, Civil Litigation

G Monahan
Family Law, Children and the Law, Contract
Law, Legal Education, Pre-Admission Legal
Skills and Training

A Mowbray
Information and Technology Law, Legal
Computer Applications

V Nagarajan
Restrictive Trade Practices, Corporations
Law, Discrimination Law

B Olliffe
Legal Education, Dispute Resolution,
Property Law

R Pettit
Legal Aid, Advocacy

S Smith
Law and Medicine, Professional Misconduct
and Discipline

D Spencer
Contract Law, Dispute Resolution,
Pre-Admission Legal Education, Advocacy

P Stewart
Torts, Family Law, Civil Litigation, Industrial
Law

A Stuhmcke
Health and Law, Administrative Law, Legal
Education, Jurisprudence

J Taggart
Computer Law, Migration and Nationality
Law, Business Law

R Tong
Commercial Law, Easements, Ecclesiastical
Law, Voluntary Associations

P Underwood
Land Dealings, Land Law

R Watt
Federal Constitutional Law, Legal History,
Legal Research, Legal Bibliography,
Administrative Law

M Whitehead
Company Law

C Ying
Contract Law, Insurance Law, Maritime Law,
Evidence

J Zetler
Medico-legal, Torts, Children and the Law,
Revenue Law, Family Law, Dispute
Resolution

Staff list

Professor and Dean of Law

D Barker, LLB (Lond), MPhil (Kent), LLM (Hons) (Cantab), DipLG (Kent), GradDipLegPrac (UTS), FCIS, ACI Arb, FAIM, FIMgt, MACE, Solicitor of the Supreme Court of NSW and the High Court of Australia

Associate Dean

A S Mowbray, BSc, LLB (UNSW), Solicitor of the Supreme Court of NSW and ACT

Professors

S K N Blay, LLB (Hons) (Ghana), LLM (ANU), PhD (Tas)

D E Flint, AM, LLM (Syd), BSc (Ecs) (Lond), DSU (Paris), Solicitor of the Supreme Courts of NSW and England

Associate Professors

M A Adams, BA (Hons), LLM (Lond), FCIS, AIMM, MACE (Director, Undergraduate Supply Programs)

K Cutbush-Sabine, Dr Jur (Zur), LLM (Hons) (Lond), MInstAM (UK)

P B C Griffith, LLB, BJur (Monash), LLM (Lond)

R J Watt, BCom, DipLib (UNSW), LLB (Syd), LLM (Hons) (UTS), Solicitor of the Supreme Court of NSW (Law Collection Consultant)

Senior Lecturers

S Carr-Gregg, BCom, LLB (UNSW), LLM (UTS), Solicitor of the Supreme Court of NSW

T Chiu, BSocSci (Hons) (Chinese HK), LLB (UNSW), GradDipLegPrac, PhD (UTS), Solicitor of the Supreme Court of NSW and the High Court of Australia, Solicitor and Barrister of the Supreme Court of ACT, Mediator CCPIT, Henan, China

P Egri, BA, LLB (Syd), MCogSc (UNSW)

M B Evans, BA (Hons), LLB, LLM (Syd), LLM (Hons) (Cantab), Barrister of the Supreme Court of NSW

P Keyzer, BA (Hons), LLB (Hons), LLM (Syd), Solicitor of the Supreme Court of NSW

G Monahan, BA (Macq), LLB (Syd), LLM (UNSW), Graduate Certificate in Higher Education (UTS), Solicitor of the Supreme

Court of NSW and the High Court of Australia, Notary Public (Director, Professional Programs)

G A Moore, BA, LLM (Syd), Barrister of the Supreme Court of NSW and ACT and the High Court of Australia

V Nagarajan, BEc, LLB (Macq), LLM (Monash), Solicitor of the Supreme Court of NSW

S F Smith, BA, MHA (UNSW), LLM, SJD (Syd), Solicitor of the Supreme Court of NSW
W J Taggart, RFD, BA, LLB, LLM (Syd), Solicitor of the Supreme Court of NSW and the High Court of Australia, Registered Migration Agent

P Underwood, BA, LLM (Syd), Solicitor of the Supreme Court of NSW

C Ying, BA (Manit), LLM (Lond), Barrister at Law of Lincoln's Inn and the Supreme Court of NSW

Lecturers

K Bubna-Litic, BJuris, LLB (UWA), LLM (Syd), Barrister and Solicitor of the Supreme Court of Western Australia

J A Cooper BEc, DipEd (Syd), LLB (UNSW), LLM (Syd), MHed (UNSW), Solicitor of the Supreme Court of NSW and Attorney of the New York Bar

P Crofts, BEc, LLB (Hons) (Syd)

R A Davis, BEc, LLB (Hons) LLM (Syd), Solicitor of the Supreme Court of NSW (Director, Undergraduate Programs)

P Edmundson, BJuris, LLB (UNSW)

I D Ellis-Jones, BA, LLB (Syd), LLM (UTS), Solicitor of the Supreme Court of NSW and the High Court of Australia

K C Gould, BA, DipEd (Macq), LLB (Hons) (UTS)

P L Hutchison, BCom (UNSW), BCom (Hons 1) (Witw), MA Law (Oxon)

J A H Lancaster, BA, LLB (Hons) (Macq), RGN, Solicitor of the Supreme Court of NSW

M Langford, BA, LLB (Macq), LLM (Syd), Graduate Certificate in Higher Education (UTS), Solicitor of the Supreme Court of NSW

T Libesman, BA, LLB (Macq)

D Meltz, LLM (Syd), SJD (UTS), Solicitor of the Supreme Court of NSW

B M Olliffe, BA (Hons), LLB (Syd), Solicitor of the Supreme Court of NSW

R Pettit, BA, LLB (Macq), LLM (Syd),
Graduate Certificate in Higher Education
(UTS), Solicitor of the Supreme Court of
NSW and the High Court of Australia
P Stewart, LLB, LLM (Syd), Solicitor of the
Supreme Court of NSW
A Stuhmcke, BA, LLB (Hons) (Macq),
Solicitor of the Supreme Court of NSW
R Tong, LLB (Syd), LLM (Lond), Solicitor of
the Supreme Court of NSW and the High
Court of Australia
P M Whitehead, BA, LLB (UNSW), LLM
(Lond), Solicitor of the Supreme Court of
NSW and the High Court of Australia
J Zetler, RGN, RPN, BA (Syd), LLM (UTS)
RCNA, Solicitor of the Supreme Court of NSW

Clinical Practitioners

J Dobies, BA, LLB (Syd), MBA (Macq),
Solicitor of the Supreme Court of NSW
L Ellis, BA, LLB (Syd), Solicitor and Barrister
of the Supreme Court of NSW and the High
Court of Australia
D Hipsley, LLB (UTS), Barrister of the
Supreme Court of NSW and the High Court
of Australia and ACT
J Hussain, BA, LLB (Syd), DipEd (UNE), Dip
Shariah Law Practice, MCL (IIU), Solicitor of
the Supreme Court of NSW
P Lothian, BA (Hons) (Syd), DipLaw (LPAB),
Solicitor of the Supreme Court of NSW and
the High Court of Australia
D Spencer, BA, LLB (Syd), GDLP, LLM
(UTS), Solicitor of the Supreme Court of
NSW and the High Court of Australia

Visiting Professors

M Pryles, LLB (Melb), LLM (SMU Texas),
SJD (Melb), Barrister and Solicitor of the
Supreme Courts of Victoria and ACT,
Solicitor of the Supreme Court of NSW
The Hon. A Rogers, QC, LLB (Hons) (Syd)
R Vermeesch, LLM (Syd)

Adjunct Professors

D Bennett, QC, LLB (Tas)
M Marshan, SAB, Solicitor of the Supreme
Court of NSW

Administrative staff

Faculty Manager

E G Marsh, BA (Open), MM (UTS)

Senior Administrative Officer

P Williams, BA (Syd)

Administrative Officer

P Holt, BA (Auck)

Administrative Assistants

V Cooper

J Donovan, BA (UNSW)

M Fenaughty

V John

S Turnbull

R Wyllie, BA (Syd), DipLaw (LPAB)

Administrative Secretaries

N Grierson

N Lemaire

D Margaritis

L Martin

C Wong

Computer Systems Engineers

A Boyd, BCompSc (W'gong)

Australian Legal Information Institute

Co-Director

A Mowbray, LLB, BSc (UNSW), Solicitor of
the Supreme Court of NSW

Manager

G King, BJuris, LLB (UNSW)

Manager of Primary Materials

P T H Chung, BEc (Hons), LLB (Syd)

Administrator

T Gill, BSc (Hons) (Uni College of Swansea,
UK)

Project Officer (Primary Materials)

D Austin

Project Officer (Special Projects)

D Irvine, LLB, BA (Hons) (UNSW)

Project Officer (Treaty Materials)

Vacant

Project Officer (Council for Aboriginal Reconciliation and Australian Human Rights Information Centre)

K Magarey, BA, LLB (Hons) (Adel)

Project Officer (Secondary Materials)

Vacant

Community Law and Research Centre

Director

I D Ellis-Jones, BA LLB (Syd), LLM (UTS),
Solicitor of the Supreme Court of NSW and
the High Court of Australia

Solicitor

Vacant

Manager

P O'Brien, LLB (UTS)

Centre for Dispute Resolution

Director

M Scott, BA, DipEd, LLB (UNSW)
GradDipLegPrac, LLM (UTS)

Administrative Secretary

V Cooper

International and Commercial Law Centre

Director

Professor S K N Blay, LLB (Hons) (Ghana),
LLM (ANU), PhD (Tas)

Administrative Secretary

N Lemaire

International Institute for Negotiation and Conflict Management

Executive Officer

G Brown, BComm, LLB (UNSW), Solicitor of
the Supreme Courts of NSW, England and
Wales, and the High Court of Australia,
Accredited Mediator

Manager

M Conley-Taylor, BA, LLB (Melb), MALD
(Fletcher), Solicitor of the Supreme Court of
Victoria, Accredited Mediator (NY)

Index

A

Accounting Module 1 122
 Accounting Module 2 122
 Addresses and telephone numbers 6
 Administration of Criminal Justice 74
 Administrative Law 70
 Admiralty Law 97
 Admiralty Law (LS) 110
 Advanced Administrative Law 84, 93
 Advanced Administrative Law (LS) 110
 Advanced Audit and Computer Security 122
 Advanced Commercial Law 117
 Advanced Companies and Securities Law 116
 Advanced Company Law 79
 Advanced Comparative Law – The Common Law 98
 Advanced Comparative Law for Civil Lawyers 105
 Advanced Computerised Legal Research 102
 Advanced Computerised Legal Research (LS) 112
 Advanced Conflict of Laws 84
 Advanced Constitutional Law 84, 93
 Advanced Constitutional Law (LS) 111
 Advanced Contracts 82
 Advanced Corporate Insolvency and Restructuring 100
 Advanced Corporate Insolvency and Restructuring (LS) 108
 Advanced Criminal Law 79
 Advanced European Union Law 102
 Advanced European Union Law (LS) 109
 Advanced Family Law 81
 Advanced Family Law: Proprietary Remedies 100
 Advanced Industrial Law 119
 Advanced International Economic Law 97
 Advanced International Economic Law (LS) 109
 Advanced Legal Accounting 73
 Advanced Legal Drafting 73
 Advanced Legal Research 92
 Advanced Media Law 95
 Advanced Media Law: Libel Law and Privacy 103
 Advanced Media Law: Libel Law and Privacy (LS) 112
 Advanced Mediation 98
 Advanced Public Law 83
 Advanced Remedial Law: Damages 96
 Advanced Remedial Law: Equitable Remedies 96
 Advanced Revenue Law 117

Advanced Taxation 119
 Advanced Taxation Law 77
 Air Law 94
 Air Law (LS) 110
 Alphabetical list of subjects 123
 Applied Legal Research 120
 Applied Research Skills 122
 Applying for UTS courses 11
 Assessment 22, 47
 Assignments, Lodging of 22
 AustLII 126
 Australasian Legal Information Institute, The 126
 Australian Indigenous Customary Law – Incorporating Indigenous Land Issues 90
 Austudy, eligibility for 17

B

Bachelor of Arts in Communication (Journalism)/Bachelor of Laws 37
 Bachelor of Arts in Communication (Media Arts and Production)/Bachelor of Laws 38
 Bachelor of Arts in Social Science/Bachelor of Laws 39
 Bachelor of Arts/Bachelor of Laws 34
 Bachelor of Business/Bachelor of Laws 32
 Bachelor of Laws 27
 Bachelor of Laws in Australian Indigenous Law 30
 Bachelor of Laws/Bachelor of Arts in International Studies 40
 Bachelor of Medical Science/Bachelor of Laws 36
 Bachelor of Science in Computing Science/Bachelor of Laws 33
 Bachelor of Science/Bachelor of Laws 36
 Banking Law 94, 116
 Banking Law (LS) 108
 Biomedical Law and Bioethics 87
 Boards and committees 129
 Business Bankruptcy 117
 Business Law 115
 Business Law Project 121

C

Campus maps 7
 Capital Gains Tax 95
 Capital Gains Tax (LS) 111
 Carriage of Goods by Sea 97
 Carriage of Goods by Sea (LS) 110
 Centre for Dispute Resolution 126
 Centres within the Faculty 126
 Children and the Law 85

Chinese Law and Legal Systems 97
 Chinese Law and Legal Systems (LS) 106
 Chinese Trade and Investment Law 96
 Chinese Trade and Investment Law (LS) 106
 Citizenship and Immigration Law 82
 Combined degrees 40
 Commercial and Estate Practice 72
 Commercial Arbitration (Domestic) 99
 Committees 129
 Communications Law 80
 Community Dispute Resolution 101
 Community Law and Research Centre 126
 Community Legal Research 86
 Companies and Securities Law 119
 Company Law 116
 Comparative Law A 74
 Comparative Law B 74
 Comparative Law Research Project 102
 Computer Law 104
 Computer Law (LS) 113
 Computerised Legal Information Systems 94
 Conflict of Laws 87
 Construction Industry Dispute
 Resolution 99
 Contemporary Business Law 119
 Contemporary Issues in Taxation 121
 Copyright Law 100
 Copyright Law (LS) 108
 Corporate Accounting Issues 122
 Corporate Insolvency and
 Administration 115
 Corporate Insolvency and Restructuring 96
 Corporate Insolvency and
 Restructuring (LS) 107
 Corporate Law 70
 Corporations, Finance and Securities 94
 Corporations, Finance and
 Securities (LS) 108
 Courses and codes, list of 19
 Courses
 Postgraduate 44
 Undergraduate 20
 Court-based Dispute Resolution 101
 Criminal and Civil Law – Indigenous
 Perspectives 89
 Criminal Law 69
 Criminology 76
 Crisis Negotiation 104
 Cross-institutional enrolment 44
 Current Issues in Corporate Law 102
 Current Issues in Corporate Law (LS) 112
 Current Issues in Industrial Law 120
 Current Law Reform Proposals – Indigenous
 Perspectives 90
 Current Problems of Public
 International Law 92
 Current Problems of Public
 International Law (LS) 105
 Customs Duties/Levies 118

D

Dean's Message 14
 Deceptive Trade Practices and Product
 Liability 78, 94
 Deceptive Trade Practices and Product
 Liability (LS) 106
 Deferment of enrolment 46
 Degrees
 Combined 40
 Double 32
 New Double 37
 Design Law 96
 Design Law (LS) 107
 Dispute Resolution 83, 97
 Dispute Resolution (S) 121
 Dispute Resolution in Commerce 101
 Doctor of Juridical Science 49
 Doctor of Philosophy 48
 Double degrees 32
 Double degrees, New 37

E

Economic Law in Eastern Europe 98
 Economic Law in Eastern Europe (LS) 109
 Economic Law of the People's Republic
 of China 102
 Economic Law of the People's Republic
 of China (LS) 106
 Electives 20
 Employment Legislation 120
 Environmental Dispute Resolution 101
 Environmental Law 78
 Environmental Law in Business 117
 Equity and Trusts 70
 European Union Anti-Trust Law 98
 European Union Anti-Trust Law (LS) 109
 European Union Law 93
 European Union Law (LS) 108
 Exemptions 23, 44
 Extension (non-award) study 67
 External award study 66

F

Faculty Board in Law 129
 Faculty information 14
 Faculty Mission Statement 14
 Faculty of Law Advisory Committee 129
 Faculty of Law Regulations 25
 Family Dispute Resolution 100
 Family Law 88
 Family Law and Women's Perspectives –
 Aboriginal and Torres Strait Islander
 People 89
 Federal Constitutional Law 70
 Fee exemptions 44
 Fees 45
 Finance Law 85

Forensic Science Case Study 122
 Franchising Law 98
 Franchising Law (LS) 108

G

Graduate Certificate in Comparative Law 61
 Graduate Certificate in Dispute Resolution 55
 Graduate Certificate in Law for Secondary Teachers 64
 Graduate Certificate in Legal Practice (Stage 1) 58
 Graduate Certificate in Continuing Legal Practice (Stage 2) 59
 Graduate Diploma in Australian Law 59
 Graduate Diploma in Law for Secondary Teachers 64
 Graduate Diploma in Legal Studies 63
 General University information 5

H

Health Care Law 114
 Honours 24
 Human Rights 75

I

In Practice 73
 Indigenous Context of Australian Law 113
 Indigenous Dispute Resolution 91, 113
 Indigenous Land Rights – A Comparative and International Perspective 113
 Indigenous Peoples and the Law 86
 Indirect Taxation 118
 Indonesian Trade and Investment Law 97
 Indonesian Trade and Investment Law (LS) 106
 Industrial and Intellectual Property 75
 Industrial and Labour Law 115
 Industrial Dispute Resolution 101
 Industrial Law 83, 119
 Information
 Centres 11
 Faculty 14
 General University 5
 Students 16
 Inquiries 15
 Insolvency 87
 Insurance Contracts 115
 International and Commercial Law Centre 127
 International and Comparative Law Project 93
 International Aspects of Australian Taxation Law 118
 International Banking and Financial Law 95
 International Banking and Financial Law (LS) 108

International Business Arbitration:
 Chinese Perspectives 104
 International Business Arbitration:
 Chinese Perspectives (LS) 113
 International Business Law 103, 120
 International Business Law and Regulation 117
 International Business Transactions 92
 International Business Transactions (LS) 105
 International Commercial Arbitration 99
 International Commercial Arbitration (LS) 107
 International Commercial Dispute Resolution 94
 International Commercial Dispute Resolution (S) 103
 International Economic Law 77, 92
 International Economic Law (LS) 105
 International Institute for Negotiation and Conflict Management 128
 International Law and Treaty Obligations, State and Regional Protocols – Indigenous Peoples 90
 International Law, the Environment and Technological change 111
 International Monetary Law 100
 International Monetary Law (LS) 106
 International students 45
 International Taxation 95
 International Taxation 1 120
 International Taxation 2 119
 International Trade Law 83, 94
 International Trade Law (LS) 105
 Introduction to Insolvency Law 114
 Introduction to Taxation Law 113

J

Jessup International Moot 80
 Jurisprudence 75
 Jurisprudence: Aspects of Justice in Modern Legal Systems 99

L

Labour Law 76
 Land Dealings 79
 Land Tax and Payroll Tax 118
 Law and Computers 76
 Law and Contracts 116
 Law and Finance 117
 Law and Medicine 81, 97
 Law and Medicine (LS) 112
 Law and Natural Resources 85
 Law and the Manager 116
 Law for Managers – Administration 120
 Law for Managers – Health 121
 Law for Marketing Management 115
 Law for Third Sector Managers 116

Law in Context 111
 Law of Contract 68
 Law of Evidence 71
 Law of Futures and Derivatives 104
 Law of Futures and Derivatives (LS) 112
 Law of Insurance 78
 Law of Prescribed Interests and Collective Investments 104
 Law of Prescribed Interests and Collective Investments (LS) 113
 Law of Tort 69
 Law Students' Society 16
 Law subjects 23
 Legal Accounting and Professional Responsibility 72
 Legal Aspects of Contracts Administration 118
 Legal Aspects of Human Reproduction and Child Protection 114
 Legal Issues and Disadvantaged Groups 114
 Legal Issues for Community Managers 121
 Legal Issues in Telecommunications 116
 Legal Method 85
 Legal Process 72
 Legal Process and History 68
 Legal Research 68
 Legal Skills and Advocacy 72
 Legal System 122
 List of courses and codes 19
 List of staff 132
 Litigation 72
 Local Government Law 79
 Lodging of assignments 22

M

Maritime Law 93
 Maritime Law (LS) 109
 Marketing Legislation in Australia 120
 Master of Comparative Law 60
 Master of Dispute Resolution 53
 Master of Laws (by coursework) 52
 Master of Laws (by thesis) 51
 Master of Legal Studies 62
 Master of Taxation Law 56
 Media Law 85
 Members, services 16
 Message from the Dean 14
 Migration Law 102
 Moot 91

N

Negotiating Skills 73
 Negotiation 98
 New Double degrees 37
 Non-award students 21
 Non-Law electives 21
 Non-Law subjects 24

O

Overseas students 46

P

Parking 16
 Patent Law of Australia 96
 Patent Law of Australia (LS) 107
 Personal Property 70
 Plagiarism 22
 Planning and Development Law 1 93
 Planning and Development Law 1 (LS) 110
 Planning and Development Law 2:
 Pollution Control Legislation 102
 Planning and Development Law 2:
 Pollution Control Legislation (LS) 110
 Postgraduate
 Courses 44
 Subjects 92
 Supply programs 65
 Practical Legal Training courses
 (Professional Program) 58
 Practice and Procedure 71
 Principal dates for 1998 12
 Private International Air Law 104
 Private International Air Law (LS) 113
 Private International Law 100
 Private International Law (LS) 109
 Prizes 18
 Professional Conduct 73
 Property Transactions 72
 Psychology and Dispute Resolution 112
 Public International Law 74

R

Readings in International Business Law 121
 Real Property 69
 Regulations of the Faculty of Law 25
 Remedies 71
 Research interests of staff 130
 Research Paper 98
 Research Paper (DR) 103
 Research Project 95
 Research Project (DR) 103
 Research Project (LS) 105
 Research Project 4 80
 Restrictive Trade Practices 79, 95
 Restrictive Trade Practices (LS) 106
 Revenue Law 88, 117

S

- Sale of Goods 88
- Scholarships 18, 44
- Securities Market Regulation 115
- Services to members 16
- Social Security Law 84
- Staff list 132
- Stamp Duties 118
- Strata Titles and Community Schemes 77
- Students
 - Information for 16
 - Law Students' Society (LSS) 16
 - Non-award 21
 - Overseas 46
- Subjects
 - Alphabetical list of 123
 - Descriptions 68
 - Law 23
 - Non-Law 24
 - Offered by other faculties 122
 - Open to other faculties 21
 - Postgraduate 92
 - Undergraduate 68
- Succession 88
- Summer program in Law 22
- Superannuation Law 100
- Superannuation Law (LS) 111

T

- Tax Administration 102
- Tax Administration (LS) 111
- Tax Procedures, Sales Tax and Stamp Duties 94
- Tax Procedures, Sales Tax and Stamp Duties (LS) 110
- Taxation Module 121
- Taxation of Partnerships and Trusts 104
- Taxation of Partnerships and Trusts (LS) 114
- Taxation Paper 121
- Taxation Project 121
- Trademarks Law of Australia 96
- Trademarks Law of Australia (LS) 107
- Transport Law – Selected Problems 82

U

- Undergraduate
 - Courses 20
 - Subjects 68
 - Supply programs 42
 - Supply subjects 42, 114
- University Graduate School 44
- University information, General 5
- University medal 25
- UTS Information Centres 11

V

- Victim–Offender Dispute Resolution 99

W

- Women and the Law 81
- Work Management 73
- World Order and Indigenous Peoples 111

University of Technology, Sydney

PO Box 123

Broadway NSW 2007

Australia

Telephone (02) 9514 2000

Course inquiries within Australia

Information Service (02) 9514 1222

email info.office@uts.edu.au

International inquiries

International Programs +61 2 9514 1531

email intlprograms@uts.edu.au

World Wide Web <http://www.uts.edu.au>